

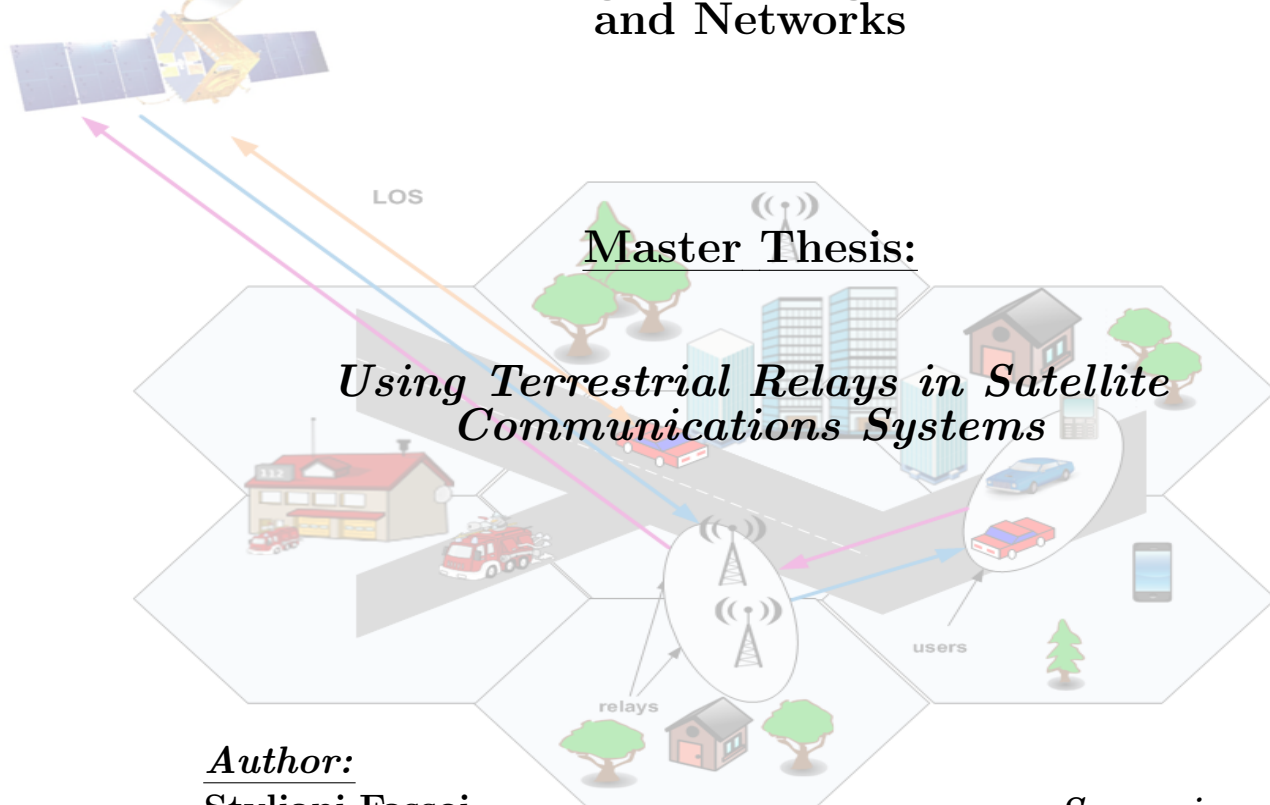

University of Piraeus
Department of Digital Systems

Post Graduate Program in Digital Communications
and Networks



Master Thesis:

*Using Terrestrial Relays in Satellite
Communications Systems*

Author:

Styliani Fassoi
AM: ME/10078
stella.fassoi@gmail.com

Supervisors:

Prof. Athanasios Kanatas

October 2012

Πανεπιστήμιο Πειραιώς



The present dissertation completed with the cooperation of Piraeus University and University of Luxembourg, and was funded in the framework of CORE project CO2SAT under the supervision of Prof. Björn Ottersten and Dr. Symeon Chatzinotas. In addition, the valuable aid of the researcher PhD candidate Dimitrios Christopoulos was determinant. I am very glad to be given the chance to live a unique experience as an assigned member in the SnT (Interdisciplinary Centre for Security, Reliability and Trust), a special section of the University of Luxembourg.

Πανεπιστήμιο Πειραιώς

This thesis is dedicated to my parents, my sister and my grandmothers who supported all my choices and efforts.

Πανεπιστήμιο Πειραιώς

Abstract

This thesis is divided into two parts; the first part describes and analyzes all the necessary for the subject theory whereas the second part presents a specific system model, its simulation and finally the desirable results. The theoretical section opens with an introduction to wireless, cooperative and satellite communications, building step by step the knowledge needed for the most important part which is the performance evaluation through simulation. The purpose of the present thesis is to analyze the usage of terrestrial relays in MIMO multi-beam satellite systems implementing techniques such as amplify and forward (AF). The system model consists of the source node, multi-relay nodes and the destination node, all equipped with multiple antennas. We focus more on standard linear detection methods including the zero-forcing (ZF) technique and the minimum mean square error (MMSE) technique. The results show that the performance of the linear detection methods is worse than that of other nonlinear receiver techniques but sometimes are preferable because of their low complexity of hardware implementation. However, the results can be improved without increasing the complexity significantly using an ordered successive interference cancellation (OSIC) method. By the simulations we observe how BER is behaving firstly with the four linear detection ZF, MMSE, SIC-MMSE and SIC-ZF for the cases “With Beam Gain Matrix” and “Without Beam Gain Matrix”, secondly with the increase of amplification factor and lastly with different kinds of modulation. Also, we reach the conclusion of which is the best position for the users in each beam in order to maximize the gain. Finally, the calculated average capacity is presented when increasing the number of relays.

Πανεπιστήμιο Πειραιώς

Περίληψη

Η παρούσα διπλωματική εργασία χωρίζεται σε δύο μέρη. Το πρώτο μέρος περιγράφει και αναλύει όλα τα απαραίτητα θεωρητικά θέματα, ενώ το δεύτερο μέρος παρουσιάζει ένα συγκεκριμένο μοντέλο συστήματος, τη προσομοίωσή του και τα επιθυμητά αποτελέσματα. Το θεωρητικό μέρος ξεκινάει με μια εισαγωγή στις ασύρματες, συνεργατικές και δορυφορικές επικοινωνίες χτίζοντας έτσι βήμα-βήμα τη γνώση που απαιτείται για το πιο σημαντικό μέρος το οποίο είναι η προσομοίωση. Ο σκοπός της παρούσας διπλωματικής εργασίας είναι να αναλυθεί η χρήση των επίγειων αναμεταδοτών σε MIMO (πολλαπλές κεραιές στην είσοδο και έξοδο) πολυκυφελωτό δορυφορικό σύστημα, εφαρμόζοντας τεχνικές όπως amplify and forward (AF) η οποία ενισχύει το σήμα και το προωθεί. Το συγκεκριμένο μοντέλο συστήματος αποτελείται από τον κόμβο πηγής με πολλαπλές κεραιές, τους πολλαπλούς κόμβους αναμεταδοτών με επίσης πολλαπλές κεραιές για κάθε κόμβο αναμεταδότη και τον κόμβο προορισμού που και εδώ εφαρμόζονται πολλαπλές κεραιές. Εστιάζουμε κυρίως στις τυπικές γραμμικές τεχνικές ανίχνευσης συμπεριλαμβανομένης της τεχνικής μηδενισμού (ZF) και της τεχνικής του ελάχιστου μέσου τετραγωνικού σφάλματος (MMSE). Τα αποτελέσματα δείχνουν ότι η απόδοση των γραμμικών μεθόδων ανίχνευσης είναι χειρότερη από εκείνη των άλλων μη γραμμικών τεχνικών δέκτη, αλλά κάποιες φορές είναι προτιμότερες εξαιτίας της πολυπλοκότητας της εφαρμογής του υλικού. Ωστόσο τα αποτελέσματα μπορούν να βελτιωθούν χωρίς σημαντική αύξηση της πολυπλοκότητας, χρησιμοποιώντας μια μέθοδο ακύρωσης διαδοχικών παρεμβολών (OSIC) Από τις προσομοιώσεις παρατηρούμε πως συμπεριφέρεται το BER αρχικά με τις τέσσερις γραμμικές τεχνικές ανίχνευσης ZF, MMSE, SIC-ZF, SIC MMSE για τις περιπτώσεις “με τη χρήση του πίνακα κέρδους κυψέλης” και “χωρίς τη χρήση του πίνακα κέρδους κυψέλης”, δεύτερον με την αύξηση του παράγοντα ενισχύσεως και τέλος με διαφορετικά είδη διαμόρφωσης. Επίσης, μπορούμε να καταλήξουμε στο συμπέρασμα ποια είναι η καλύτερη θέση των χρηστών σε κάθε κυψέλη για να μεγιστοποιείται το κέρδος. Τέλος, η υπολογισμένη μέση χωρητικότητα παρουσιάζεται αυξάνοντας κάθε φορά τον αριθμό των κεραιών και των αναμεταδοτών.

Πανεπιστήμιο Πειραιώς

Acknowledgements

My sincere thanks to Professor Athanasios Kanatas , Professor Björn Ottersten, Dr Symeon Chatzinotas and the PhD candidate Dimitrios Christopoulos for their valuable input, patience, guidance and support for all this time.

Thanks to University of Luxembourg for the hospitality and comfort they provided me.

Also, special thanks to all the professors from the Postgraduate program who were more than willing to share with all the students their knowledge and gave us the chance to build a strong and competitive background.

Special thanks, firstly, to my uncle, aunt and my cousins from German, who not only took me in but also encouraged and supported me.

Last but not least, a very special thanks to my beloved family and my close friends for their patience, psychological support and all for all the encouragement the provided me all these years.

Πανεπιστήμιο Πειραιώς

Contents

Abstract	v
Περίληψη	vii
Acknowledgements	ix
Table of Contents	xiii
List of Figures	xvi
Abbreviations	xix
List of Symbols	xxi
1 Introduction	1
1.1 Overview of Wireless Communications	4
1.2 Overview of Satellite Communications	4
1.3 Overview of Cooperative Communications (Relay)	5
1.4 Outline	6
2 Wireless Communications	7
2.1 The wireless channel	8
2.1.1 Exploiting multiple antennas in wireless	9
<i>Array Gain</i>	10
<i>Diversity Gain</i>	10
<i>Spatial Multiplexing (SM)</i>	11
<i>Interference reduction</i>	11
2.2 MIMO	12
2.2.1 Narrowband MIMO model	13
2.2.2 Singular Value Decomposition (SVD)	14
2.2.3 Summary of MIMO	17
2.3 Relay channel	18
2.3.1 Overview of relay protocols	18
2.3.2 Background and Milestones	20
3 Cooperative Communications	23
3.1 Cooperative Architectures	23
3.1.1 Transparent Relaying Protocols	25

3.1.2	Regenerative Relaying Protocols	26
3.2	Canonical Information Flows	28
4	Satellite Communications	31
4.1	Introduction	31
4.1.1	The origin of Satellites	31
4.1.2	Types of Satellites	32
4.1.3	Communications via Satellite	33
4.1.4	Characteristic features of communication satellites	34
4.2	Multibeam systems	35
4.2.1	Joint Processing in SatComs	37
	<i>Multibeam Joint Processing in the Forward Link</i>	37
	<i>Multibeam Joint Processing in the Return Link</i>	38
4.2.2	Multibeam Satellite Network- Advantages	38
4.3	Satellite component of NGN: Integrated and Hybrid networks	39
4.3.1	Background	40
4.3.2	Integrated/hybrid systems (Definition and architecture)	40
	<i>Integrated systems</i>	40
	<i>Hybrid systems</i>	41
4.4	Channel- differences with terrestrial	41
4.4.1	Satellite with terrestrial system	42
4.4.2	Satellite with terrestrial relay	42
5	Terrestrial Relays in MIMO Multibeam Satellite System	45
5.1	System model	45
5.2	Without Beam Gain Matrix	52
5.2.1	Bit-Error-Rate (BER)	52
	<i>BER</i>	53
	<i>Amplification Factor</i>	54
	<i>MPSK</i>	55
	<i>Random number antennas and relays</i>	56
5.2.2	Capacity	57
	<i>Capacity</i>	57
	<i>Comparisons of capacity results with single relay antenna</i>	58
	<i>Comparisons of capacity results with multiple relay antennas</i>	59
5.3	With Beam Gain Matrix	60
5.3.1	Beams	62
	<i>Frequency reuse</i>	62
	<i>User Distributions</i>	62
5.3.2	BER for Multibeam MIMO system	64
	<i>BER</i>	64
	<i>User Positions</i>	65
5.3.3	Gain	66
6	Conclusion	69
6.1	Conclusions	69
6.2	Future work	69

CONTENTS

7 References

xiii

71

Πανεπιστήμιο Πειραιώς

Πανεπιστήμιο Πειραιώς

List of Figures

2.1	Antenna configurations	10
2.2	MIMO	14
2.3	Relay channel	18
2.4	Protocol I	19
2.5	Protocol II	19
2.6	Protocol III	20
2.7	Traditional forwarding protocol	20
2.8	Background and Milestones	21
3.1	Traditional relaying vs Distributed Space-Time relaying	24
3.2	Availability Direct Link vs Absence Direct Link	24
3.3	Supportive Relaying vs Cooperative Relaying	25
3.4	Transparent Relaying Protocols	26
3.5	Regenerative Relaying Protocols	27
3.6	Serial relaying	28
3.7	Parallel relaying	29
3.8	Space-Time relaying	29
3.9	Composites Thereof	30
4.1	Intercontinental	33
4.2	Two Earth Stations	34
4.3	A multibeam satellite system with Ground Station serving a 7-beam cluster	36
5.1	System Model	45
5.2	Multibeam System Model	47
5.3	OSIC	50
5.4	BER	53
5.5	Amplification factor	54
5.6	mPSK	55
5.7	Different results	56
5.8	Capacity	58
5.9	Comparisons capacity with single relay antenna	59
5.10	Comparisons capacity with multiple relay antennas	60
5.11	Frequency reuse	62
5.12	Distributions	63
5.13	Multibeam MIMO system	65
5.14	User Positions	66

5.15 Rician vs Rician with beam gain matrix	67
6.1 Future System Model	70

Πανεπιστήμιο Πειραιώς

Abbreviations

ABC	Always Best Connected
AF	Amplify and Forward
AMC	Adaptive Modulation and Coding
BER	Bit Error Rate
BS(s)	Base Station(s)
BSM	Broadband Satellite Multimedia
BSS	Broadcasting Satellite Services
CF	Compress and Forward
CQI	Channel Quality Information
D	Destination
DF	Decode and Forward
EF	Estimate and Forward
FL	Forward Link
FSL	Free Space Loss
GEO	Geostationary
GF	Gather and Forward
GW	GateWay
HEO	High Elliptical Orbiting
ITU	International Telecommunication Union
LAN	Local Area Network
LD	Linear Detector
LEO	Low-Earth-Orbiting

LF	Linear-Process and Forward
LMS	Land Mobile channel
LoS	Line of Sight
MEO	Medium-Earth Orbiting
MIMO	Multiple-Input Multiple-Output
MIMO-MU	MIMO MultiUser
MISO	Multiple Input Single Output
MMSE	Minimum Mean Square Error
MoDiS	Mobile Digital broadcast Satellite
MS(s)	Mobile Station(s)
NGN	Next Generation Network
nLf	NonLinear-Process and Forward
OFDM	Orthogonal Frequency Division Multiplexing
OFDMA	Orthogonal Frequency Division Multiple Access
OSIC	Ordered Successive Interference Cancellation
PF	Purge and Forward
QoS	Quality of Service
R	Relays
RF	RadioFrequency
RS(s)	Relay Station(s)
S	Source
SatCom(s)	SATellite COMmunication(s)
SDMA	Space Division Multiple Access
SER	Symbol-error rate
SIC-MMSE	Successive Interference Cancellation- Minimum Mean Square Error
SIC-ZF	Successive Interference Cancellation- Zero Forcing
SIMO	Single Input Multiple Output
SINR	Signal-to-Interference-plus-Noise Ratio

Abbreviations

SISO	Single Input Single Output
SM	Spatial Multiplexing
SM	Spatial Multiplexing
SNR	Signal to Noise Ratio
SNR	Signal-to Noise Ratio
ST	Space Time
STC	Space Time Coding
STTD	Space Time Transmit Diversity
SVD	Singular Value Decomposition
WLANs	Wireless Local Area Networks
WSN	Wireless Sensor Network
ZF	Zero forcing

Πανεπιστήμιο Πειραιώς

List of Symbols

\mathbf{I}_m	$m \times m$ identity matrix
$(\cdot)^H$	Complex conjugate transpose (Hermitian)
$(\cdot)^{-1}$	Inverse operation
N_t	Transmit antennas
N_r	Receive antennas
K	Users in the source node
$(\cdot)^T$	Transpose operation
ρ	Average SNR per receive antennas
$(\cdot)^*$	Complex conjugate
$tr(\cdot)$	Trace of a matrix
R_x	Covariance matrix
$\mathbf{U}, \mathbf{V}, \mathbf{Q}$	Unitary matrices
$\mathbf{\Lambda}$	Diagonal matrix
λ_i	Diagonal elements of $\mathbf{\Lambda}$
R	Number of relay nodes
M_r	Number of relay's receiving antennas
M_t	Number of relay's transmitting antennas
\mathbf{y}_1	Received signal on relays
\mathbf{y}_2	Received signal on destination
\mathbf{H}_1	Channel matrix between source-relay

\mathbf{H}_2	Channel matrix between relay destination
α	Amplification factor
\mathbf{n}_R	Vector of zero mean additive white Gaussian noise at the relay
\mathbf{n}_D	Vector of zero mean additive white Gaussian noise at the destination
\mathbf{W}	Weight matrix
\mathbf{x}	Transmit data vector
$\tilde{\mathbf{x}}$	Estimated value
$\ \cdot\ $	Norma
E	Average value
$(\hat{\cdot})$	Estimated value
J	Bessel functions
θ	Off-axis angle
λ	Wavelength
d_0	Satellite altitude
\mathbf{B}	Beam Gain matrix
\odot	Component-wise multiplication

Chapter 1

Introduction

History of Wireless and Satellite Communications

The first wireless networks were developed in the pre-industrial age. These systems transmitted information over line-of-sight distances (later extended by telescopes) using smoke signals, torch signaling, flashing mirrors, signal flares, or semaphore flags. An elaborate set of signal combinations was developed to convey complex messages with these rudimentary signals. Observation stations were built on hilltops and along roads to relay these messages over large distances. These early communication networks were replaced first by the telegraph network (invented by Samuel Morse in 1838) and later by the telephone. In 1895, a few decades after the telephone was invented, Marconi demonstrated the first radio transmission from the Isle of Wight to a tugboat 18 miles away, and radio communications was born. Radio technology advanced rapidly to enable transmissions over larger distances with better quality, less power, and smaller, cheaper devices, thereby enabling public and private radio communications, television, and wireless networking.

Early radio systems transmitted analog signals. Today most radio systems transmit digital signals composed of binary bits, where the bits are obtained directly from a data signal or by digitizing an analog signal. A digital radio can transmit a continuous bit stream or it can group the bits into packets. The latter type of radio is called a packet radio and is often characterized by bursty transmissions: the radio is idle except when it transmits a packet, although it may transmit packets continuously. The first network based on packet radio, ALOHANET, was developed at the University of Hawaii in 1971. This network enabled computer sites at seven campuses spread out over four islands to communicate with a central computer on Oahu via radio transmission. The network architecture used a star topology with the central computer at its hub. Any two computers could establish a bi-directional communications link between them by going through the central hub. ALOHANET incorporated the first set of protocols for channel access and routing in packet radio systems, and many of the underlying principles in these protocols are still in use today. The U.S. military was extremely interested in this combination of packet data and broadcast radio. Throughout the 1970s and early 1980s the Defense Advanced Research Projects Agency (DARPA) invested significant resources to develop networks using packet radios for tactical communications in the battlefield. The nodes in these ad hoc wireless networks had the ability to self-configure (or reconfigure) into a network without the aid of any established infrastructure. DARPA's investment in ad hoc

networks peaked in the mid 1980s, but the resulting systems fell far short of expectations in terms of speed and performance. These networks continue to be developed for military use. Packet radio networks also found commercial application in supporting wide area wireless data services. These services, first introduced in the early 1990s, enabled wireless data access (including email, file transfer, and Web browsing) at fairly low speeds, on the order of 20 kbps. No strong market for these wide area wireless data services ever really materialized, due mainly to their low data rates, high cost, and lack of “killer applications”. These services mostly disappeared in the 1990s, supplanted by the wireless data capabilities of cellular telephones and wireless local area networks (WLANs).

The introduction of wired Ethernet technology in the 1970s steered many commercial companies away from radio-based networking. Ethernet’s 10-Mbps data rate far exceeded anything available using radio, and companies did not mind running cables within and between their facilities to take advantage of these high rates. In 1985 the Federal Communications Commission (FCC) enabled the commercial development of wireless LANs by authorizing the public use of the Industrial, Scientific, and Medical (ISM) frequency bands for wireless LAN products. The ISM band was attractive to wireless LAN vendors because they did not need to obtain an FCC license to operate in this band. However, the wireless LAN systems were not allowed to interfere with the primary ISM band users, which forced them to use a low power profile and an inefficient signaling scheme. Moreover, the interference from primary users within this frequency band was quite high. As a result, these initial wireless LANs had very poor performance in terms of data rates and coverage. This poor performance (coupled with concerns about security, lack of standardization, and high cost (the first wireless LAN access points listed for 1400 dollars as compared to a few hundred dollars for a wired Ethernet card) resulted in weak sales. Few of these systems were actually used for data networking: they were relegated to low-tech applications like inventory control. The current generation of wireless LANs, based on the family of IEEE 802.11 standards, have better performance, although the data rates are still relatively low (maximum collective data rates of tens of Mbps) and the coverage area is still small (around 100 m). Wired Ethernets today offer data rates of 1 Gbps, and the performance gap between wired and wireless LANs is likely to increase over time without additional spectrum allocation. Despite their lower data rates, wireless LANs are becoming the preferred Internet access method in many homes, offices, and campus environments owing to their convenience and freedom from wires. However, most wireless LANs support applications, such as email and Web browsing, that are not bandwidth intensive. The challenge for future wireless LANs will be to support many users simultaneously with bandwidth-intensive and delay-constrained applications such as video. Range extension is also a critical goal for future wireless LAN systems.

By far the most successful application of wireless networking has been the cellular telephone system. The roots of this system began in 1915, when wireless voice transmission between New York and San Francisco was first established. In 1946, public mobile telephone service was introduced in 25 cities across the United States. These initial systems used a central transmitter to cover an entire metropolitan area. This inefficient use of the radio spectrum (coupled with the state of radio technology at that time) severely limited the system capacity: thirty years after the introduction of mobile telephone service, the New York system could support only 543 users.

A solution to this capacity problem emerged during the 1950s and 1960s as researchers

at AT&T Bell Laboratories developed the cellular concept. Cellular systems exploit the fact that the power of a transmitted signal falls off with distance. Thus, two users can operate on the same frequency at spatially separate locations with minimal interference between them. This allows efficient use of cellular spectrum, so that a large number of users can be accommodated. The evolution of cellular systems from initial concept to implementation was glacial. In 1947, AT&T requested spectrum for cellular service from the FCC. The design was mostly completed by the end of the 1960s; but the first field test was not until 1978, and the FCC granted service authorization in 1982 (by which time much of the original technology was out of date). The first analog cellular system, deployed in Chicago in 1983, was already saturated by 1984, when the FCC increased the cellular spectral allocation from 40 MHz to 50 MHz. The explosive growth of the cellular industry took almost everyone by surprise. In fact, a marketing study commissioned by AT&T before the first system rollout predicted that demand for cellular phones would be limited to doctors and the very rich. AT&T basically abandoned the cellular business in the 1980s to focus on fiber optic networks, eventually returning to the business after its potential became apparent. Throughout the late 1980s (as more and more cities saturated with demand for cellular service) the development of digital cellular technology for increased capacity and better performance became essential.

The second generation of cellular systems, first deployed in the early 1990s, was based on digital communications. The shift from analog to digital was driven by its higher capacity and the improved cost, speed, and power efficiency of digital hardware. Although second-generation cellular systems initially provided mainly voice services, these systems gradually evolved to support data services such as email, Internet access, and short messaging. Unfortunately, the great market potential for cellular phones led to a proliferation of second-generation cellular standards: three different standards in the United States alone, other standards in Europe and Japan, and all incompatible. The fact that different cities have different incompatible standards makes roaming throughout the United States and the world with only one cellular phone standard impossible. Moreover, some countries have initiated service for third-generation systems, for which there are also multiple incompatible standards. As a result of this proliferation of standards, many cellular phones today are multimode: they incorporate multiple digital standards to facilitate nationwide and worldwide roaming and possibly the first-generation analog standard as well, since only this standard provides universal coverage throughout the United States.

Satellite systems are typically characterized by the height of the satellite orbit: low-earth orbit (LEOs at roughly 2000 km altitude), medium-earth orbit (MEOs, 9000 km), or geosynchronous orbit (GEOs, 40,000 km). The geosynchronous orbits are seen as stationary from the earth, whereas satellites with other orbits have their coverage area change over time. The concept of using geosynchronous satellites for communications was first suggested by the science-fiction writer Arthur C. Clarke in 1945. However, the first deployed satellites (the Soviet Union's Sputnik in 1957 and the NASA/Bell Laboratories' Echo-1 in 1960) were not geosynchronous owing to the difficulty of lifting a satellite into such a high orbit. The first GEO satellite was launched by Hughes and NASA in 1963; GEOs then dominated both commercial and government satellite systems for several decades.

Geosynchronous satellites have large coverage areas, so fewer satellites (and dollars) are necessary to provide wide area or global coverage. However, it takes a great deal of

power to reach the satellite, and the propagation delay is typically too large for delay-constrained applications like voice. These disadvantages caused a shift in the 1990s toward lower-orbit satellites. The goal was to provide voice and data service competitive with cellular systems. However, the satellite mobile terminals were much bigger, consumed much more power, and cost much more than contemporary cellular phones, which limited their appeal. The most compelling feature of these systems is their ubiquitous worldwide coverage, especially in remote areas or third-world countries with no landline or cellular system infrastructure. Unfortunately, such places do not typically have large demand or the resources to pay for satellite service either. As cellular systems became more widespread, they took away most revenue that LEO systems might have generated in populated areas. With no real market left, most LEO satellite systems went out of business.

A natural area for satellite systems is broadcast entertainment. Direct broadcast satellites operate in the 12-GHz frequency band. These systems offer hundreds of TV channels and are major competitors to cable. Satellite-delivered digital radio has also become popular. These systems, operating in both Europe and the United States, offer digital audio broadcasts at near-CD quality [11].

1.1 Overview of Wireless Communications

Wireless communications is, by any measure, the fastest growing segment of the communications industry. As such, it has captured the attention of the media and the imagination of the public. Cellular systems have experienced exponential growth over the last decade and there are currently about four billion users worldwide. Indeed, cellular phones have become a critical business tool and part of everyday life in most developed countries, and they are rapidly supplanting antiquated wireline systems in many developing countries. In addition, wireless local area networks currently supplement or replace wired networks in many homes, businesses, and campuses. Many new applications (including wireless sensor networks, automated highways and factories, smart homes and appliances, and remote telemedicine) are emerging from research ideas to concrete systems. The explosive growth of wireless systems coupled with the proliferation of laptop computers and smartphones suggests a bright future for wireless networks, both as stand-alone systems and as part of the larger networking infrastructure. However, many technical challenges remain in designing robust wireless networks that deliver the performance necessary to support emerging applications. We then discuss the wireless vision in more detail, including the technical challenges that must still be overcome. We describe current wireless systems along with emerging systems and standards. The gap between current and emerging systems and the vision for future wireless applications indicates that much work remains to be done to make this vision a reality [11].

1.2 Overview of Satellite Communications

A communications satellite (or COMSAT) is an artificial satellite sent to space for the purpose of telecommunications. Modern communications satellites use a variety of orbits

including geostationary orbits, Molnya orbits, elliptical orbits and low (polar and non-polar Earth orbits).

For fixed (point-to-point) services, communications satellites provide a microwave radio relay technology complementary to that of communication cables. They are also used for mobile applications such as communications to ships, vehicles, planes and hand-held terminals, and for TV and radio broadcasting.

The first artificial satellite was the Soviet Sputnik 1, launched on October 4, 1957 and equipped with an onboard radio-transmitter that worked on two frequencies: 20.005 and 40.002 MHz. The first American satellite to relay communications was Project SCORE in 1958, which used a tape recorder to store and forward voice messages. It was used to send a Christmas greeting to the world from U.S. President Dwight D. Eisenhower. NASA launched an Echo satellite in 1960; the 100-foot (30 m) aluminized PET film balloon served as a passive reflector for radio communications. Courier 1B, built by Philco, also launched in 1960, was the world's first active repeater satellite.

Telstar was the first active, direct relay communications satellite. Belonging to AT&T as part of a multi-national agreement between AT&T, Bell Telephone Laboratories, NASA, the British General Post Office, and the French National PTT (Post Office) to develop satellite communications, it was launched by NASA from Cape Canaveral on July 10, 1962, the first privately sponsored space launch. Relay 1 was launched on December 13, 1962, and became the first satellite to broadcast across the Pacific on November 22, 1963.

An immediate antecedent of the geostationary satellites was Hughes' Syncom 2, launched on July 26, 1963. Syncom 2 revolved around the earth once per day at constant speed, but because it still had north-south motion, special equipment was needed to track it.

1.3 Overview of Cooperative Communications (Relay)

Cooperation is not a natural characteristic attributed to humans. The typical human horizon is focused on short-term gains, which might be due to our instinct-driven subconscious occupying a grander importance than we dare to admit. Cooperating with other individuals or entities, however, usually means that short-term losses may translate into long-term gains, something history has proved to hold true but humans for some reason rarely ever understand. Any cooperative technology depending solely on human decisions is hence a priori doomed to fail. By contrast, if machines have access to some computerized decision making engines only, cooperative schemes become viable communication techniques and are likely to occupy an important place in the technological landscape of the 21st century.

For this reason, wireless cooperative communication systems have received significant attention in the past decade and (due to their theoretically infinite design degrees of freedom) a large body of highly useful but also often confusing and contradicting research papers has emerged. Indeed, when we commenced research in this area in 1999, online search engines yielded a handful of papers; today, Google yields almost one million hits when searching for "cooperative wireless communications" [8].

The basic idea behind cooperative communication can be traced back to the groundbreaking work of Cover and El Gamal on the information theoretic properties of the relay channel. That work analyzed the capacity of the three-node network consisting of a source, destination and a relay. It was assumed that all nodes can operate in the same band, so the system can be decomposed into a broadcast channel (BC) and a multiple access channel (MAC) from the view-point of the source and the destination, respectively.

In the year 1998, Andrew Sendonaris, Elza Erkip and Behnaam Aazhang proposed a new form of spatial diversity, in which diversity gain was achieved via the cooperation of mobile users. That is, in each cell, each user has a “partner”. Each of two partners is responsible for transmitting not only his own information, but also the information of his partner, which they receive and detect. This idea can be characterized as the specific application of traditional relay model [38].

1.4 Outline

The remainder of this document is structured as follows:

Chapter 2 analyzes all the theoretical issues about the wireless channel, the relay channel and the MIMO systems in general. The importance of the MIMO architecture is presented.

Chapter 3 describes the Cooperative Communications. Two big categories are recognized: transparent and regenerative relaying protocols where each of them has other subcategories which are also shown in this chapter.

Chapter 4 focuses in the Satellite Communications. An analysis about the satellites and the history about satellites has been made. In addition, we refer to the Multi-beam Systems for the first time. Finally, this chapter overviews several hybrid systems and shows the differences between a terrestrial system and a satellite with a terrestrial relay system.

Chapter 5 covers the system model which is followed by simulations and results comparison on BER (Bit Error Rate) and Capacity for the techniques Zero-Forcing (ZF), Minimum Mean Square Error (MMSE), Successive Interference Cancellation specifically SIC-ZF and SIC-MMSE.

Chapter 6 holds the conclusion where we comment on the outcomes.

Chapter 7 lists the References.

Chapter 2

Wireless Communications

The continually increasing number of users and the rise of resource-demanding services emanate the necessity for higher rate broadband communications systems. Wireless cellular networks, in particular, have to be designed and deployed with unavoidable constraints on the available bandwidth and transmit power. As the number of new users increases, meeting the rising demand for high data rate services with the available resources has become a challenging research problem. While in traditional infrastructure networks, the upper limit for the performance of the point-to-point link between the source (S) and the destination (D) is bounded by the Shannon capacity and further degraded by interferences, advances in radio transceiver techniques such as multiple-input multiple-output (MIMO) architectures and cooperative or relay-assisted communications have led to an enhancement in the capacity of contemporary systems.

MIMO communications rely on the deployment of multiple antennas at the receiver side, the transmitter side, or both, and by sufficiently separating these antennas (of same polarization). The MIMO technique can be used to increase the robustness of a link as well as the link's throughput. The main intuition behind MIMO lies in the introduction of multiple channels ideally uncorrelated. Thus, the proper exploitation of multiple transmission paths can either increase the channel capacity or provide diversity gains. Unfortunately, the incorporation of multiple antennas in most modern mobile devices may be challenging due to their small sizes.

Cooperative diversity or relay-assisted communication has been proposed as an alternative solution where several distributed terminals cooperate to transmit/ receive their intended signals. In this scheme, the source wishes to transmit a message to the destination, but obstacles degrade the S-D link quality. To address this issue, the introduction of relays (R) is considered. Hence, the message is also received by the relay terminals, which can retransmit it to a desired destination, if needed. The destination may combine the transmissions received by the source and relays in order to decode the message.

The limited power and bandwidth resources of the cellular networks and the multipath fading nature of the wireless channels have also made the idea of cooperation particularly attractive for wireless cellular networks. Moreover, the desired ubiquitous coverage demands users must be served in the most unfavorable channel conditions (e.g., cell-edge scenario). In conventional cellular architectures (without relay assistance) increasing capacity along with coverage extension dictates dense deployment of base stations (BSs) which turns out to be a cost-wise inefficient solution for service providers. A relay station

(RS) , which has less cost and functionality than the BS, is able to extend the high data rate coverage to remote areas in the cell under power and spectral constraints.

By allowing different nodes to cooperate and relay each other's messages to the destination, cooperative communication also improves the transmission quality. This architecture exhibits some properties of MIMO systems; in fact a virtual antenna array is formed by distributed wireless nodes each with one antenna. Since channel impairments are assumed to be statistically independent, in contrast to conventional MIMO systems, the relay-assisted transmission is able to combat these impairments caused by shadowing and path loss in S-D and relay-destination (R-D) links. To this end, a novel approach has been proposed in which the communication between transmitter and receiver is done in multiple hops through a group of relay stations. This cooperative MIMO relaying scheme creates a virtual antenna array (VAA) by using the antennas of a group of RSs. These RSs transmit the signal received from the BS (or previous hops) cooperatively on different channels to the receiving terminal (downlink case) or the signal that the transmitting terminal wants to send to the BS (uplink case). This system can be modeled as a MIMO system although the real receiver (downlink) or transmitter (uplink) only has one antenna. Since the relaying mobile stations (MSs) introduce additional noise and there is a double Rayleigh channel effect, the scheme is expected to perform below the corresponding MIMO diversity gain when used for spatial multiplexing.

The combination of relaying and orthogonal frequency-division multiple access (OFDMA) techniques also has the potential to provide high data rate to user terminals everywhere. Interest in orthogonal frequency-division multiplexing (OFDM) is therefore growing steadily, as it appears to be a promising air-interface for the next generation of wireless systems due, primarily, to its inherent resistance to frequency-selective multipath fading and the flexibility it offers in radio resource allocations. Likewise, the use of multiple antennas at both ends of a wireless link has been shown to offer significant improvements in the quality of communication in terms of both higher data rates and better reliability at no additional cost of spectrum or power. These essential properties of OFDMA and MIMO, along with the effectiveness of cooperative relaying in combating large scale fading and enhancing system capacity immediately motivate the integration of these technologies into one network architecture [12].

2.1 The wireless channel

According to [8], the nature of the wireless channel is pivotal to the understanding of the gains of cooperative systems. We shall expose here some of its fundamental properties. As such, the transmitted signal is impaired by three effects:

- **Pathloss:** Averaging the received power at a particular distance over a sufficiently large area, yields the loss in power or the pathloss versus distance. The pathloss law is deterministic and traditionally behaves linearly in decibels, that is as an inverse law in linear scale. Pathloss limits interference but also rapidly diminishes the useful signal power. Any technique improving on the pathloss is hence highly appreciated by network planners.
- **Shadowing:** Averaging the received power at a particular distance over an area of radius of approximately shadowing coherence distance yields a variation in the

received power around the pathloss. This variation is referred to as shadowing. The shadowing law is random and is traditionally modeled as Gaussian in decibels, that is lognormal in linear scale. Shadowing is one of the most detrimental performance factors in modern communications systems since it cannot be absorbed by suitable channel codes, thus causing non-availabilities of links referred to as outages. Any technique improving on the shadowing outage is hence highly appreciated.

- **Fading:** Not averaging the signal at all allows one to observe fading as a signal fluctuation around pathloss and shadowing. It is caused by the constructive and destructive addition of the signal traveling via multiple propagation paths.

2.1.1 Exploiting multiple antennas in wireless

Figure 2.1 illustrates different antenna configurations for ST wireless links. SISO (Single Input Single Output) is the familiar wireless configuration, SIMO (Single Input Multiple Output) has a single transmit antenna and multiple N_r receive antennas, MISO (Multiple Input Single Output) has multiple N_t transmit antennas and a single receive antenna and MIMO (Multiple Input Multiple Output) has multiple N_t transmit antennas and multiple N_r receive antennas. The MIMO-MU (MIMO MultiUser) configuration refers to the case where a base-station with multiple (N) antennas communicates with P users each with one or more antennas. We sometimes abbreviate SIMO, MISO, MIMO configurations as XIXO [31].

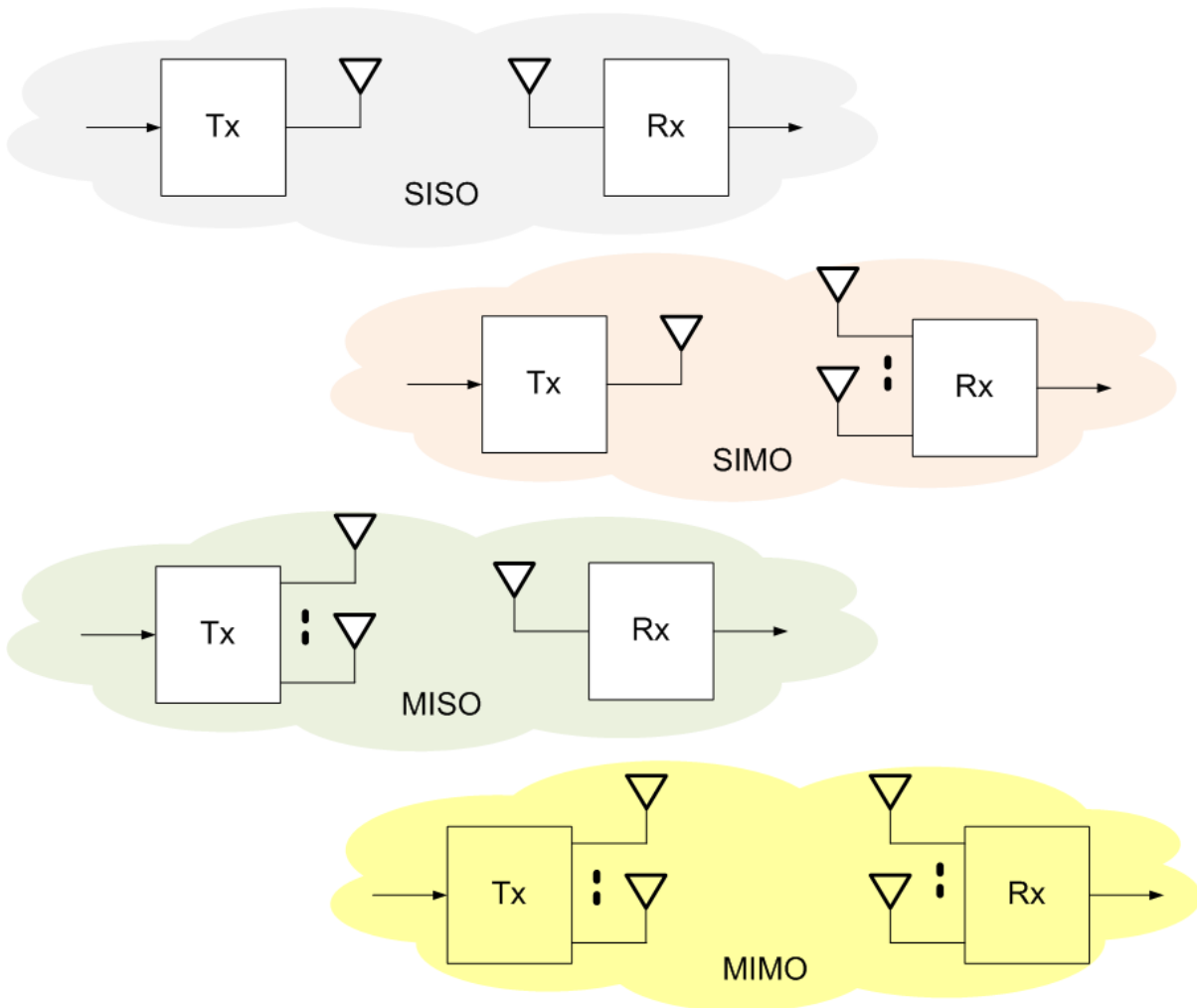

Figure 2.1: Antenna configurations in wireless systems (*Tx*: Transmitter, *Rx*: Receiver)

Array Gain

Array gain refers to the average increase in the SNR (Signal to Noise Ratio) at the receiver that arises from the coherent combining effect of multiple antennas at the receiver or transmitter or both. Consider, as an example, a SIMO channel. Signals arriving at the receive antennas have different amplitudes and phases. The receiver can combine the signals coherently so that the resultant signal is enhanced. The average increase in signal power at the receiver is proportional to the number of receive antennas. In channels with multiple antennas at the transmitter (MISO OR MIMO channels), array gain exploitation requires channel knowledge at the transmitter [31].

Diversity Gain

Signal power in a wireless channel fluctuates (or fades). When the signal power drops significantly, the channel is said to be in fade. Diversity is used in wireless channels to combat fading.

Receive antenna diversity can be used in SIMO channels [14]. The receive antennas see independently faded versions of the same signal. The receiver combines these signals

so that the resultant signal exhibits considerably reduced amplitude variability (fading) in comparison with the signal at any one antenna. Diversity is characterized by the number of the independently fading branches, also known as the diversity order and is equal to the number of receive antennas in SIMO channels.

Transmit diversity is applicable to MISO channels and has become an active area for research [42] [35] [24] [30] [17]. Extracting diversity in such channels is possible with or without channel knowledge at the transmitter. Suitable design of the transmitted signal is required to extract diversity. ST diversity coding [35] [15] [1] is a transmit diversity technique that relies on coding across space (transmit antennas) to extract diversity in the absence of channel knowledge at the transmitter. If the channels of all transmit antennas to the receive antenna have independent fades, the diversity order of this channel is equal to the number of transmit antennas.

Utilization of diversity in MIMO channels requires a combination of the receive and transmit diversity described above. The diversity order is equal to the product of the number of transmit and receive antennas, if the channel between each transmit- receive antennas pair fades independently [31].

Spatial Multiplexing (SM)

SM offers a linear (in the number of transmit- receive antenna pairs or $\min(N_r, N_t)$) increase in the transmission rate (or capacity) for the same bandwidth and with no additional power expenditure. SM is only possible in MIMO channels [32] [10] [39]. In the following we discuss the basic principles of SM for a system with two transmit and two receive antennas. The concept can be extended to more general MIMO channels.

The bit stream to be transmitted is demultiplexed into two half-rate sub-streams, modulated and transmitted simultaneously from each transmit antenna. Under favorable channel conditions, the spatial signatures of these signals induced at the receive antennas are well separated. The receiver, having knowledge of the channel, can differentiate between the two co-channel signals and extract both signals, after which demodulation yields the original sub-streams that can now be combined to yield the original bit stream. Thus SM increases transmission rate proportionally with the number of transmit- receive antenna pairs.

SM can also be applied in a multiuser format (MIMO-MU, also known as space division multiple access or SDMA). Consider two users transmitting their individual signals, which arrive at a base-station equipped with two signals with spatial filtering so that each user can decode its own signal adequately. This allows a capacity increase proportional to the number of antennas at the base-station and the number of users [31].

Interference reduction

Co-channel interference arises due to frequency reuse in wireless channels. When multiple antennas are used, the differentiation between the spatial signatures of the desired signal and co-channel signals can be exploited to reduce the interference. Interference reduction requires knowledge of the channel of the desired signal. However, exact knowledge of the interferer's channel may not be necessary.

Interference reduction (or avoidance) can also be implemented at the transmitter, where the goal is to minimize the interference energy sent towards the co-channel users

while delivering the signal to the desired user. Interference reduction allows the use of aggressive reuse factors and improves network capacity.

We note that it may not be possible to exploit all the leverages simultaneously due to conflicting demands on the spatial degrees of freedom (or number of antennas). The degree to which these conflicts are resolved depends upon the signaling scheme and receiver design [31].

2.2 MIMO

In this section we emphasize in the systems with multiple antennas at the transmitter and receiver, which are referred to as multiple input multiple output (MIMO) systems, as previously mentioned. It is a transceiver (transmitter/receiver) architecture used for wireless radio communications [36]. MIMO systems are mainly used either to increase the capacity and/or improve reliability and coverage of the transmission and the range [6] [36] [19].

MIMO technology has been a subject of research since the last decade of the twentieth century. In 1984, Jack Winters at Bell Laboratories wrote a patent on wireless communications using multiple antennas. Jack Winters in [41] presented a study of the fundamental limits on the data rate of multiple antenna systems in a Rayleigh fading environment. The concept of MIMO was introduced for two basic communication systems which are a communication system between multiple mobiles and a base station with multiple antennas and another one between two mobiles with multiple antennas. In 1993, Arogyaswami Paulraj and Thomas Kailath proposed the concept of spatial multiplexing using MIMO. They filed a patent on spatial multiplexing emphasized applications to wireless broadcast. Several articles which focused on MIMO concept were published in the period from 1986 to 1995. We mainly cite the article of Emre Telatar titled "Capacity of multi-antenna gaussian channels" [39]. This was followed by the work of Greg Raleigh and Gerard Joseph Foschini in 1996 [10] which invented new approaches involving space time coding techniques. These approaches were proved to increase the spectral efficiency of MIMO systems [34]. In 1999, Thomas L. Marzetta and Bertrand M. Hochwald published an article [28] which provides a rigorous study on the MIMO Rayleigh fading link taking into consideration information theory aspects. Afterwards, MIMO communication techniques have been developed and brought completely on new perspectives wireless channels. The first commercial MIMO system was developed in 2001 by Iospan Wireless Inc. Since 2006, several companies such as Broadcom and Intel have concerned a novel communication technique based on the MIMO technology for improving the performance of wireless Local Area Network (LAN) systems. The new standard of wireless LAN systems is named IEEE 802.11n. MIMO technology has attracted more attention in wireless communications. In fact, it was used to boost the link capacity and to enhance the reliability of the communication link. MIMO scheme is the major candidate technology in various standard proposals for the fourth-generation of wireless communication systems. Enhanced techniques for MIMO communications led to advanced technologies for achieving successful radio transmission. It promises significant improvements in spectral efficiency and network coverage. We mainly cite multiple access MIMO systems, Ad-hoc MIMO, cooperative MIMO [40] and cooperative MIMO in sensor networks [7]. Note that cooperative MIMO systems use multiple distributed

transmitting devices to improve Quality of Service (QoS) at one/multiple receivers. This was shown to bring saves in energy and to improve the link reliability in Wireless Sensor Network (WSN) where multiple sensor nodes can be cooperatively functioned [2].

In 1996, Bell Labs created the first prototype of a MIMO chip for wireless Internet use based on 16 antennas in a notebook PC talking to an access point using a proprietary technology back then and it showed a 16 times higher data rate over single antenna systems. In 1998 both PaulRaj, Gesbert and two others co-founded Gigabit Wireless to promote MIMO OFDM (orthogonal frequency division multiplexing) and Gigabit (under the new name of Iospan) was sold to Intel in 2002. The advantages of MIMO are two-fold: First it enables the increase of data rates by transmission of several independent multiplexed data streams on the different transmit antennas. Second, it can enable robust communications, especially in challenging environments for radio propagation, by sending instead redundant information over the multiple antennas. Multiple data streams enable higher data speeds, while with redundancy under less radio-friendly conditions, if one signal is disrupted by interference, the receiver can recover all data from the other, a benefit known as “diversity”.

Some of other advantages are [18]:

- Resistivity to fading (quality)
- Increased coverage
- Increased capacity
- Increased data rate
- Improved spectral efficiency
- Reduced power consumption
- Reduced cost of wireless network

The multiple antennas can be used to increase data rates through multiplexing or to improve performance through diversity. In MIMO systems the transmit and receive antennas can both be used for diversity gain.

2.2.1 Narrowband MIMO model

In this section we consider a narrowband MIMO channel. A narrowband point-to-point communication system of N_t transmit and N_r receive antennas is shown in figure 2.2.

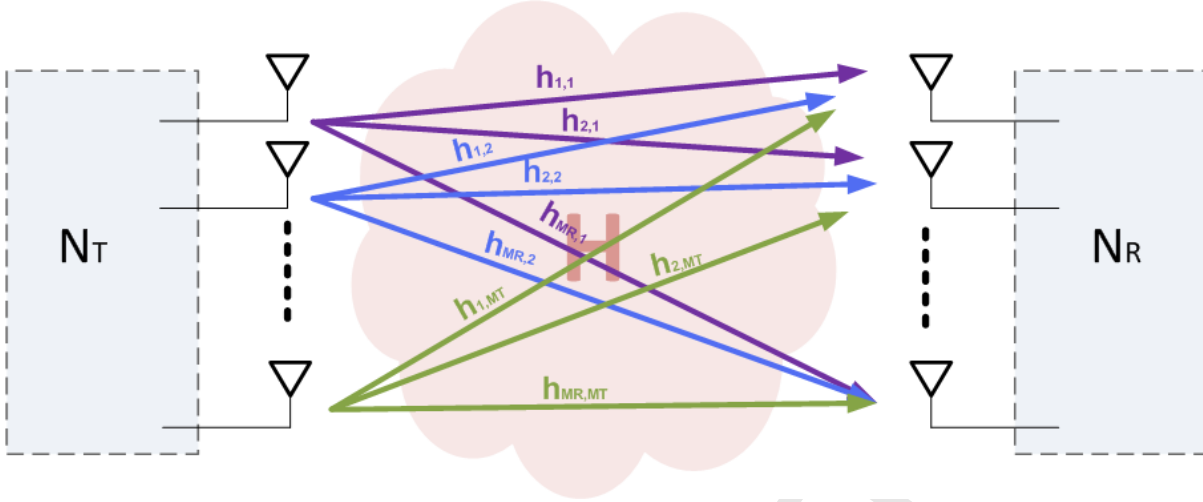

Figure 2.2: A MIMO system (M_t : Transmit antennas, M_r : Receive antennas)

This system can be represented by the following discrete time model

$$\begin{bmatrix} y_1 \\ \vdots \\ y_{N_r} \end{bmatrix} = \begin{bmatrix} h_{11} & \cdots & h_{1N_t} \\ \vdots & \ddots & \vdots \\ h_{N_r 1} & \cdots & h_{N_r N_t} \end{bmatrix} \begin{bmatrix} x_1 \\ \vdots \\ x_{N_t} \end{bmatrix} + \begin{bmatrix} n_1 \\ \vdots \\ n_{N_r} \end{bmatrix}$$

or simply as $\mathbf{y} = \mathbf{H}\mathbf{x} + \mathbf{n}$. Here \mathbf{x} represents the N_t -dimensional transmitted symbol, \mathbf{n} is the N_r -dimensional noise vector and \mathbf{H} is the $N_r \times N_t$ matrix of channel gains h_{ij} representing the gain from transmit antenna j to receive antenna i . Assuming a channel bandwidth of B and complex Gaussian noise with zero mean and covariance matrix $\sigma_n^2 \mathbf{I}_{N_r}$, where $\sigma_n^2 = N_0 B$. For simplicity, given a transmit power constraint P we will assume an equivalent model with a noise power of unity and transmit power $P/\sigma_n^2 = \rho$ where ρ can be interpreted as the average SNR per receive antenna under unity channel gain. This power constraint implies that the input symbols satisfy

$$\sum_{i=1}^{N_t} \mathbb{E}[x_i x_i^*] = \rho \quad (2.1)$$

or equivalent

$$\text{tr}(\mathbf{R}_x) = \rho \quad (2.2)$$

where $\text{tr}(\mathbf{R}_x)$ is the trace of the input covariance matrix $\mathbf{R}_x = \mathbb{E}[xx^T]$ [11].

2.2.2 Singular Value Decomposition (SVD)

We have known that multiple antennas at the transmitter or receiver can be used for diversity gain. When both the transmitter and receiver have multiple antennas, there is

another mechanism for performance gain called *multiplexing gain*. The multiplexing gain of a MIMO system results from the fact that a MIMO channel can be decomposed into a number K of parallel independent channels. By multiplexing independent data onto these independent channels, we get an K -fold increase in data rate in comparison to a system with just one antenna at the transmitter and receiver. This increased data rate is called *multiplexing gain*.

Consider a MIMO channel with $N_r \times N_t$ channel gain matrix \mathbf{H} known to both the transmitter and the receiver [11]. The matrix $\mathbf{H} \in \mathbb{C}^{N_r \times N_t}$ has a singular value decomposition (SVD), represented as

$$\mathbf{H} = \mathbf{U}\mathbf{\Sigma}\mathbf{V}^H \quad (2.3)$$

where $\mathbf{U} \in \mathbb{C}^{N_r \times N_r}$ and $\mathbf{V} \in \mathbb{C}^{N_t \times N_t}$ are unitary matrices hence satisfies $\mathbf{U}^H\mathbf{U} = \mathbf{I}_{N_r}$ and $\mathbf{V}^H\mathbf{V} = \mathbf{I}_{N_t}$ where \mathbf{I}_{N_r} and \mathbf{I}_{N_t} are $N_r \times N_r$ and $N_t \times N_t$, respectively, identities matrices, and $\mathbf{\Sigma} \in \mathbb{C}^{N_r \times N_t}$ is a rectangular matrix, whose diagonal elements are non-negative real numbers and whose off-diagonal elements are zero. The diagonal elements of $\mathbf{\Sigma}$ are the singular values of the matrix \mathbf{H} , denoting them by $\sigma_1, \sigma_2, \dots, \sigma_{N_{min}}$, where $N_{min} \triangleq \min(N_t, N_r)$. In fact, assume that $\sigma_1 \geq \sigma_2 \geq \dots \geq \sigma_{N_{min}}$, that is, the diagonal elements of $\mathbf{\Sigma}$, are the ordered singular values of the matrix \mathbf{H} . Let $K_{\mathbf{H}}$ denote the rank of \mathbf{H} . The rank of \mathbf{H} corresponds to the number of non-zero singular values (i.e., $\text{rank}(\mathbf{H}) \leq N_{min}$). In case of $N_{min} = N_t$, SVD in equation (2.3) can also be expressed as

$$\begin{aligned} \mathbf{H} &= \mathbf{U}\mathbf{\Sigma}\mathbf{V}^H \\ &= \underbrace{[\mathbf{U}_{N_{min}} \ \mathbf{U}_{N_r - N_{min}}]}_{\mathbf{U}} \underbrace{\begin{bmatrix} \mathbf{\Sigma}_{N_{min}} \\ \mathbf{0}_{N_r - N_{min}} \end{bmatrix}}_{\mathbf{\Sigma}} \mathbf{V}^H \\ &= \mathbf{U}_{N_{min}} \mathbf{\Sigma}_{N_{min}} \mathbf{V}^H \end{aligned} \quad (2.4)$$

where $\mathbf{U}_{N_{min}} \in \mathbb{C}^{N_r \times N_{min}}$ is composed of N_{min} left-singular vectors corresponding to the maximum possible nonzero singular values, and $\mathbf{\Sigma}_{N_{min}} \in \mathbb{C}^{N_{min} \times N_{min}}$ is now a square matrix. Since N_{min} singular vectors in $\mathbf{U}_{N_{min}}$ are of length N_r , there always exist $(N_r - N_{min})$ singular vectors such that $[\mathbf{U}_{N_{min}} \ \mathbf{U}_{N_r - N_{min}}]$ is unitary. In case of $N_{min} = N_r$, SVD in equation (2.3) can be expressed as

$$\begin{aligned} \mathbf{H} &= \mathbf{U}\mathbf{\Sigma}\mathbf{V}^H \\ &= \mathbf{U} \underbrace{[\mathbf{\Sigma}_{N_{min}} \ \mathbf{0}_{N_t - N_{min}}]}_{\mathbf{\Sigma}} \underbrace{\begin{bmatrix} \mathbf{V}_{N_{min}}^H \\ \mathbf{V}_{N_t - N_{min}}^H \end{bmatrix}}_{\mathbf{V}^H} \\ &= \mathbf{U}\mathbf{\Sigma}_{N_{min}} \mathbf{V}_{N_{min}}^H \end{aligned} \quad (2.5)$$

where $\mathbf{V}_{N_{min}} \in \mathbb{C}^{N_t \times N_{min}}$ is composed of N_{min} right-singular vectors. Also, we have the next expression

$$\mathbf{H}^H = \mathbf{V}\mathbf{\Sigma}\mathbf{U}^H \quad (2.6)$$

from the equations (2.6) and (2.3) will have:

$$\begin{aligned} \mathbf{H}^H\mathbf{H} &= \mathbf{V}\mathbf{\Sigma}\mathbf{U}^H\mathbf{U}\mathbf{\Sigma}\mathbf{V}^H \\ &= \mathbf{V}\mathbf{\Sigma}^2\mathbf{V}^H \end{aligned} \quad (2.7)$$

Given SVD of \mathbf{H} , the following eigen-decomposition holds:

$$\begin{aligned} \mathbf{H}\mathbf{H}^H &= \mathbf{U}\mathbf{\Sigma}\mathbf{\Sigma}^H\mathbf{U}^H \\ &= \mathbf{Q}\mathbf{\Lambda}\mathbf{Q}^H \end{aligned} \quad (2.8)$$

where $\mathbf{Q} = \mathbf{U}$ such that $\mathbf{Q}^H\mathbf{Q} = \mathbf{I}_{N_r}$ and $\mathbf{\Lambda} \in \mathbb{C}^{N_r \times N_r}$ is a diagonal matrix with its diagonal elements given as

$$\lambda_i = \begin{cases} \sigma_i^2, & \text{if } i = 1, 2, \dots, N_{min} \\ 0, & \text{if } i = N_{min}+1, \dots, N_R \end{cases} \quad (2.9)$$

As the diagonal elements of $\mathbf{\Lambda}$ in equation (2.8) are eigenvalues $\{\lambda_i\}_{i=1}^{N_r}$, equation (2.9) indicates that the squared singular values $\{\sigma_i^2\}$ for \mathbf{H} are the eigenvalues of the Hermitian symmetric matrix $\mathbf{H}\mathbf{H}^H$, or similarly, of $\mathbf{H}^H\mathbf{H}$.

For a non-Hermitian square matrix $\mathbf{H} \in \mathbb{C}^{n \times n}$ (or non-symmetric real matrix), the eigen-decomposition is expressed as

$$\mathbf{H} \underbrace{[\mathbf{x}_1 \ \mathbf{x}_2 \ \cdots \ \mathbf{x}_n]}_{\mathbf{X}} = \underbrace{[\mathbf{x}_1 \ \mathbf{x}_2 \ \cdots \ \mathbf{x}_n]}_{\mathbf{X}} \mathbf{\Lambda}_{non-H} \quad (2.10)$$

or equivalent,

$$\mathbf{H} = \mathbf{X}\mathbf{\Lambda}_{non-H}\mathbf{X}^{-1} \quad (2.11)$$

where $\{\mathbf{x}_i\}_{i=1}^n \in \mathbb{C}^{n \times 1}$ are the right-side eigenvectors corresponding to eigenvalues in $\mathbf{\Lambda}_{non-H} \in \mathbb{C}^{n \times n}$. In equation (2.11), linear independence of the eigenvectors is assumed. Comparing equation (2.8) to equation (2.11), it can be seen that the eigenvectors of a non-Hermitian matrix $\mathbf{H} \in \mathbb{C}^{n \times n}$ are not orthogonal, while those of a Hermitian matrix $\mathbf{H}\mathbf{H}^H$ are orthogonal (i.e., $\mathbf{Q}^{-1} = \mathbf{Q}^H$) [4].

2.2.3 Summary of MIMO

How MIMO works [36]

- MIMO takes advantage of multi-path
- MIMO uses multiple antennas to send multiple parallel signals (from transmitter)
- In an urban environment, these signals will bounce off trees, buildings, etc. and continue on their way to their destination (the receiver) but in different directions
- “Multi-path” occurs when the different signals arrive at the receiver at various times
- With MIMO, the receiving end uses an algorithm or special signal processing to sort out the multiple signals to produce one signal that has the originally transmitted data
- Multiple data streams transmitted in a single channel at the same time
- Multiple radios collect multipath signals
- Delivers simultaneous speed, coverage and reliability improvements

Types of MIMO [36]

MIMO involves Space Time Transmit Diversity (STTD), Spatial Multiplexing and Uplink Collaborative MIMO.

- **Space Time Transmit Diversity (STTD):** The same data is coded and transmitted through different antennas, which effectively doubles the power in the channel. This improves Signal Noise Ratio (SNR) for cell edge performance.
- **Spatial Multiplexing (SM):** the “Secret Sauce” of MIMO. SM delivers parallel streams of data to the receiver CPE by exploiting multi-path. It can double (2x2 MIMO) or quadruple (4x4) capacity and throughput. SM gives higher capacity when RF conditions are favorable and users are closer to the BTS.
- **Uplink Collaborative MIMO link:** Leverages conventional single Power Amplifier (PA) at device. Two devices can collaboratively transmit on the same sub-channel which can also double uplink capacity.

In conclusion, we have the next benefits [19]:

1. Transmission rate is dramatically increased
 - Due to the capability of spatial multiplexing
 - No additional bandwidth and transmission power required
2. Combat fading
 - Due to diversity techniques

3. Oppression of channels interferences

- The transmitter is able to control the direction in which it transmits, in order to avoid interference
- The receiver can turn the nulls of the radiation pattern to the direction of incoming interference

4. Reduction of the required power

- Increases the average signal over to noise ratio (SNR) at the receiver and so the required SNR and the required transmission power are reduced

5. Increase the capacity of cellular networks

2.3 Relay channel

Wireless networks can be classified into two major categories: traditional infrastructure networks and multi-hop networks. In traditional networks the communication is performed directly between the BS and the MS and vice versa, so, there is only one hop. Though obstacles may degrade the line-of-sight (LoS) S-D link quality in this scheme, the source makes no use of the cooperation potential of other terminals in the network to compensate for the impairments [12].

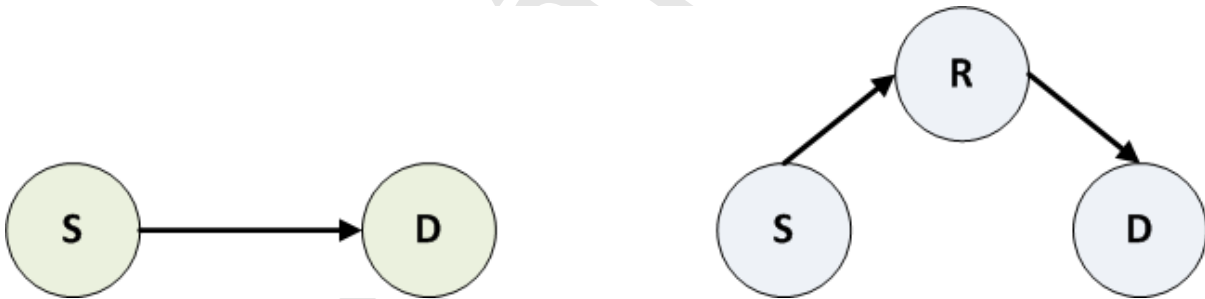

Figure 2.3: *The Relay channel , source (S), relay (R), and destination (D)*

2.3.1 Overview of relay protocols

In the half-duplex mode there is an orthogonal duplexing (in time or frequency) between the phase that the relay is receiving (relay-receive phase) and the one it is transmitting in (relay-transmit phase). This phase separation allows the definition of several half-duplex relay protocols with various degrees of broadcasting and receiving collision in each relay-receive and relay-transmit phase among the three terminals (source, destination, and relay). The number of options leads to the four protocol definitions presented in the next figures. In protocol I, the source communicates with the relay and destination during the relay-receive phase (solid lines in figure 2.4). Then, in the relay-transmit phase, the relay terminal communicates with the destination (dashed line in figure 2.4).

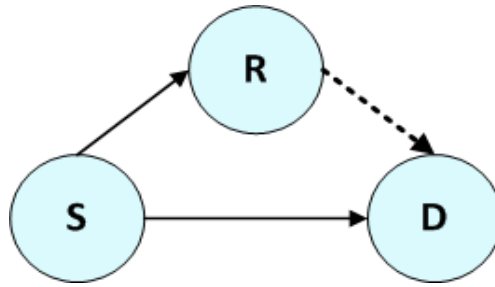

Figure 2.4: *Protocol I: Half-Duplex Relay protocol. Solid lines correspond to the transmission during the relay receive phase and dashed lines to the transmission during the relay-transmit phase*

On the other hand, in protocol II, during the relay-receive phase the source only transmits to the relay (solid line in figure 2.5). It is assumed that the destination is not able to receive the message from the source in that phase. In the relay-transmit phase, the source and relay transmit simultaneously to the destination (dashed lines in figure 2.5). Hence in the relay-transmit phase the channel becomes a multiple access channel.

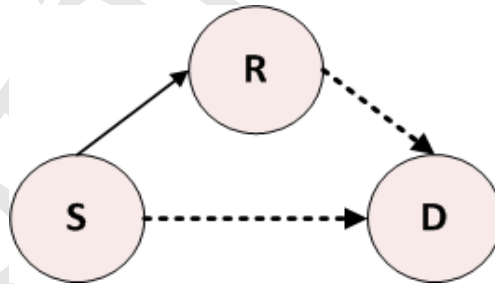

Figure 2.5: *Protocol II: Half-Duplex Relay protocol. Solid lines correspond to the transmission during the relay receive phase and dashed lines to the transmission during the relay-transmit phase*

Protocol III can be seen as a combination of protocols I and II. The source transmits to the relay and the destination (solid lines in figure 2.6) in the relay-receive phase. Then, in the relay-transmit phase, the source and the relay transmit to the destination (dashed lines in figure 2.6). Notice that the relay is transmitting during the second phase, so that it cannot be aware of the signal transmitted by the source in the second phase. This protocol can achieve a better spectral efficiency than the previous ones.

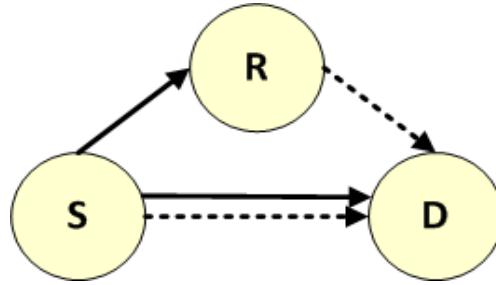

Figure 2.6: *Protocol III: Half-Duplex Relay protocol. Solid lines correspond to the transmission during the relay receive phase and dashed lines to the transmission during the relay-transmit phase*

The traditional forwarding protocol consists of a transmission from the source to the relay during the relay-*receive* phase and a transmission from the relay to the destination in the relay-*transmit* phase, as in figure 2.7.

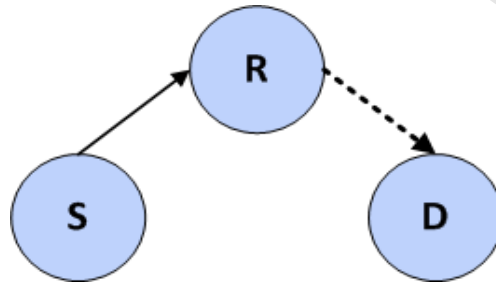

Figure 2.7: *Half-duplex forwarding protocol*

It should be emphasized that the half-duplex relay protocols defined in the first 3 figures make good use of the S-D link in contrast to the forwarding protocol. Likewise, if that link presents very bad quality compared with the S-R and R-D links, the performance obtained by protocols I, II, and III converges to the forwarding one [12].

2.3.2 Background and Milestones

Early developments concerning supportive, cooperative and space-time relaying were related but have largely emerged independently:

- **Supportive Relaying:** This simplest form of cooperation is not exactly new. Information theoretical developments stem back to the seminal contribution by van der Meulen in 1968, and by Cover and Gamal in 1979. Whilst some information theoretical contributions emerged here and there, the communication and protocol developments received a revival in the early 1990s with the 3GPP Concept Group Epsilon, driven by Vodafone. Back then, communication engineers argued that no user would agree to relay data for another user since the short-term gains of the relaying user are nil. Harrold and Nix were the first to prove by means of simulations that - whilst short-term gains were indeed sometimes unfavorable - every user gained in the long run by cooperating; they also showed that by using simple relaying, coverage holes could largely be closed in a cellular deployment.

- Cooperative Relaying:** Cooperative relaying, that is the case where at least two users help each other to boost each other's performance, has been pioneered by Sendonaris et al. in 1998. Later, around 2000, Laneman and coworkers rigorously formalized various types of supportive and cooperative relaying protocols and proved that significant performance and outage gains can be achieved. It is largely due to Laneman's seminal work that the area of cooperative communication systems commenced to flourish. A little later, Hunter and coworkers and Stefanov and Erkip were the first to propose a viable cooperative scheme based on channel coding and special code designs.
- Space-Time Relaying:** Space-time relaying had been pioneered by Dohler and coworkers in 1999 and made public to the audience of the Mobile Virtual Centre of Excellence (M-VCE), a UK national research initiative, from 2000 onwards. Their work was based on then just emerged works on space-time codes by Foschini, Alamouti and Tarokh. Subsequently and sometimes in parallel, pioneering key contributions related to distributed space-time codes and their design emerged from Laneman and Wornell and Stefanov and Erkip.

These early key contributions are summarized in a time chart in figure 2.8 [8].

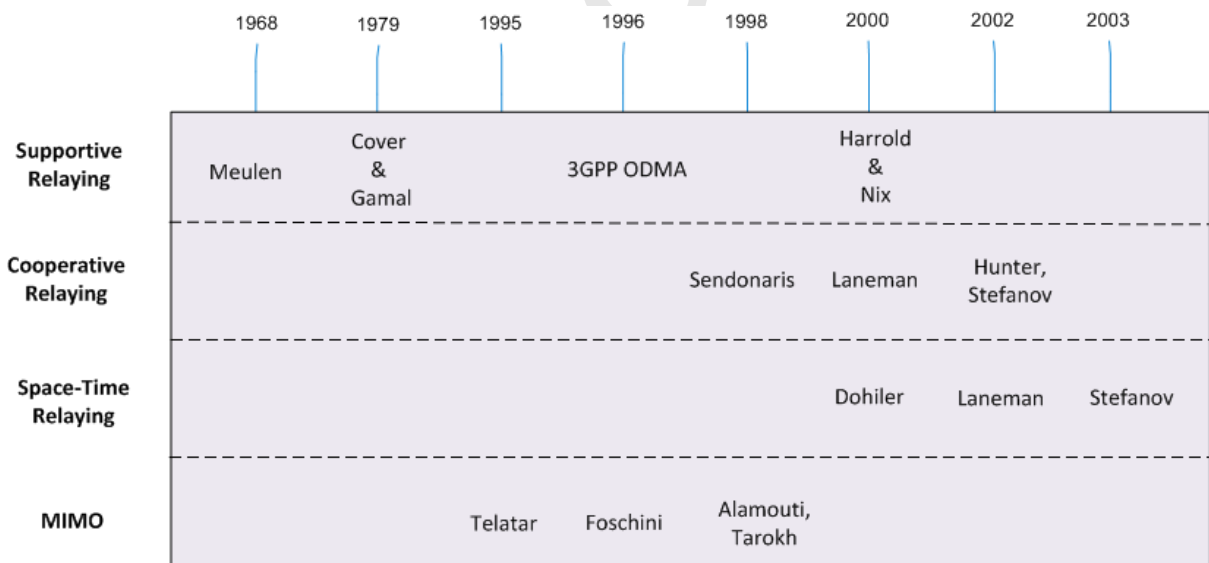

Figure 2.8: *Early key contributions in the field and their timeline of publication*

Πανεπιστήμιο Πειραιώς

Chapter 3

Cooperative Communications

3.1 Cooperative Architectures

Whilst the field of cooperative systems is very large, we list below the most important approaches for the realization of a particular cooperative architecture [8]:

- **Transparent versus Regenerative Relaying:** One of the foremost design dilemmas in cooperative systems is the choice between transparent and regenerative relaying approaches. Transparent relaying generally implies that the relay only amplifies the signal before retransmitting it. It is also possible, however, that the relay performs some other linear and non-linear operations in the analog domain, such as phase shifting, etc. Regenerative relaying, on the other hand, requires the relay to change the waveform and/or the information contents by performing some processing in the digital domain. An example is the relay receiving the information from the source, decoding, re-encoding and finally retransmitting it.
- **Traditional versus Distributed Space-Time Relaying:** Another important factor is the choice between traditional relaying and spatially distributed space-time processing relaying architectures. Traditional relaying has been around for some decades already and is realized by means of an arbitrary number of serial and/or parallel relays delivering the information from source towards destination. Space-time processing relaying, however, is realized by means of a distributed deployment of arbitrary number of (typically but not necessarily) synchronized nodes performing one of the many possible forms of distributed space-time processing. Known space-time techniques are thus applicable either directly or in modified form to these architectures, such as space-time coding, BLAST type algorithms or beamforming.

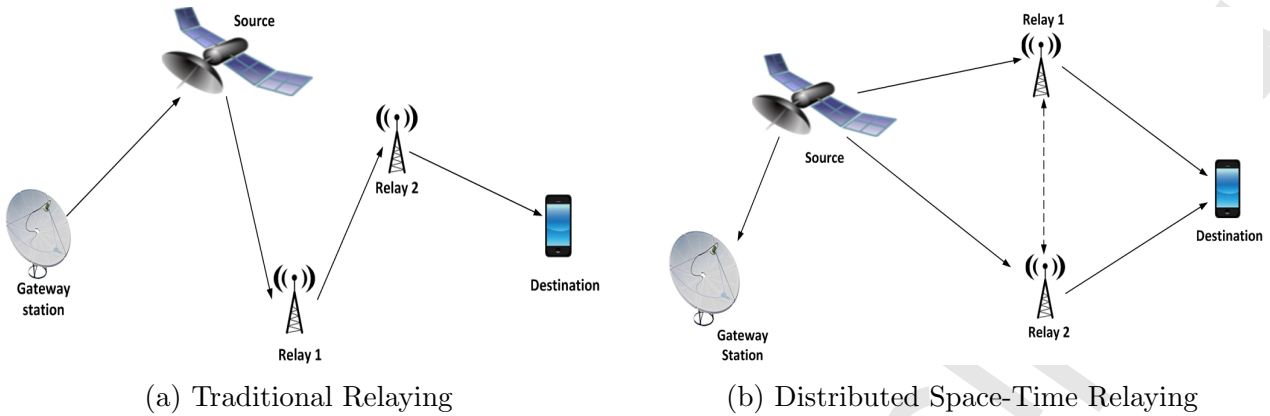

Figure 3.1: *Traditional relaying vs Distributed Space-Time relaying: Exemplification of canonical relay architectures with the choice between traditional and distributed space-time processing relaying*

- Dual-Hop versus Multi-Hop Networks:** The choice of the number of relaying stages is very important to system designers. As such, relays can be connected in series or operated in parallel. Increasing the number of serial relaying nodes increases the coverage. Increasing the number of parallel relaying nodes increases the maximum diversity gain. Note that the relay channels ought to but do not necessarily have to be orthogonal so as to minimize interference; this can be achieved by using different frequencies, time slots, codes, etc.
- Availability of Direct Link:** Depending on the propagation conditions, there may or may not be a direct link between source and destination or various relaying stages that is sufficiently strong to facilitate data transmission. Without the direct link, only pathloss gains can be achieved; with the direct link, the maximum diversity gain can also be increased. The direct link is usually available in situations where the system is capacity limited and not available where it is coverage limited.

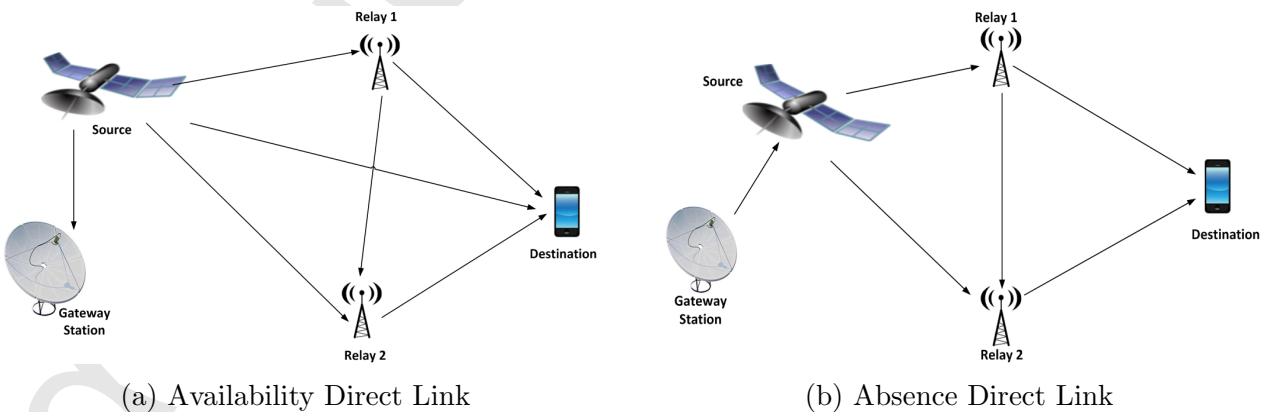

Figure 3.2: *Availability Direct Link vs Absence Direct Link: Exemplification of canonical relay architectures with the choice between the availability of a direct link versus its absence*

- **Degree of Cooperation:** One generally distinguishes between the cases of supportive relaying and cooperative relaying. Typically, placing a relay node in-between a source and destination node is referred to as supportive relaying or simply relaying. Supportive relaying can be extended to cooperative communications, where at least two cooperative nodes are each other's respective relays at the same time to boost the other's communication links. Cooperative deployments clearly boost the maximum diversity and maximum multiplexing gains and, albeit not for every node, also the pathloss gain.

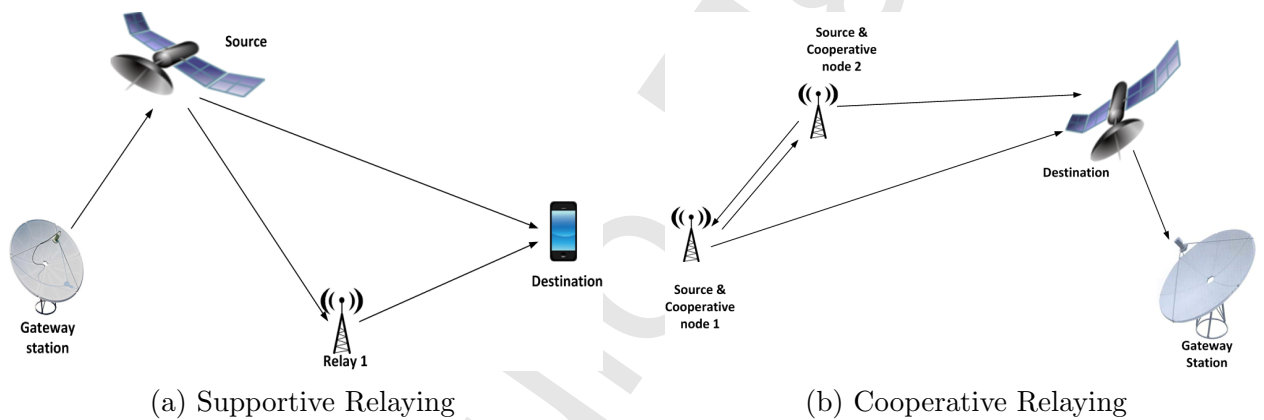

Figure 3.3: *Supportive Relaying vs Cooperative Relaying: Exemplification of canonical relay architectures with the choice between supportive and cooperative relaying*

The aforementioned design architectures have been visualized in figures 3.1, 3.2, 3.3, where we have not shown the choice between transparent and regenerative architectures as any could be either of these two. The application of combinations of these canonical cooperative architectures to some practical scenarios is briefly discussed in the subsequent section.

3.1.1 Transparent Relaying Protocols

As is well documented throughout available literature on this subject, a whole gamut of different relaying methods exists today. They can roughly be classified into two groups, that is transparent and regenerative relaying protocols.

Using the family of transparent relaying, the relay does not modify the information represented by a chosen waveform. Very simple operations are usually performed, such as simple amplification, phase rotation, etc. Since no digital operations are performed on the signal, the analog signal is received in one frequency band, amplified and momentarily retransmitted on another frequency band. Example protocols belonging to the transparent relaying family are [8]:

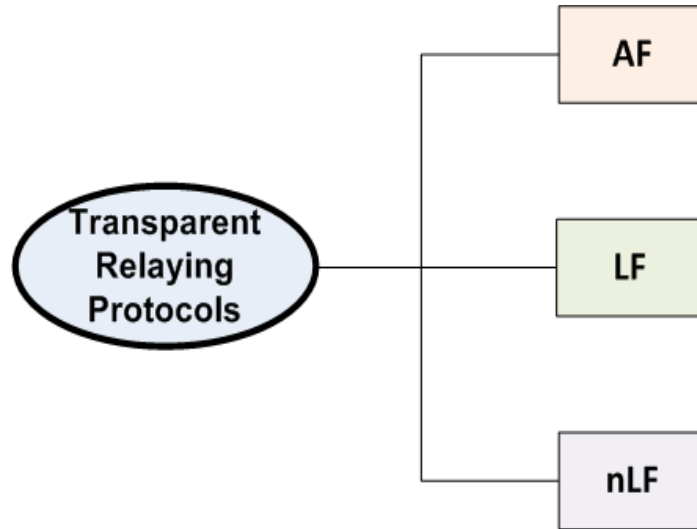

Figure 3.4: Example protocols belonging to the Transparent relaying

- **Amplify and Forward (AF):** Constituting one of the simplest and most popular relaying methods, the signal received by the relay is amplified, frequency translated and retransmitted. Different amplification factors can be used.
- **Linear-Process and Forward (LF):** This relaying method includes some other simple linear operations, which are performed on the signal in the analog domain after amplification. An example of such a linear operation is phase shifting, which facilitates the implementation of distributed beamforming.
- **Nonlinear-Process and Forward (nLF):** Not yet fully explored, this method performs some nonlinear operations on the received analog method prior to retransmission. An example application is the nonlinear amplification of the received signal which minimizes the end-to-end error rate.

3.1.2 Regenerative Relaying Protocols

In the case of regenerative relaying protocols, information (bits) or waveform (samples) is modified. This requires digital baseband operations and thus more powerful hardware. Hence, regenerative relays usually outperform transparent ones. The most prominent examples of regenerative relaying are [8]:

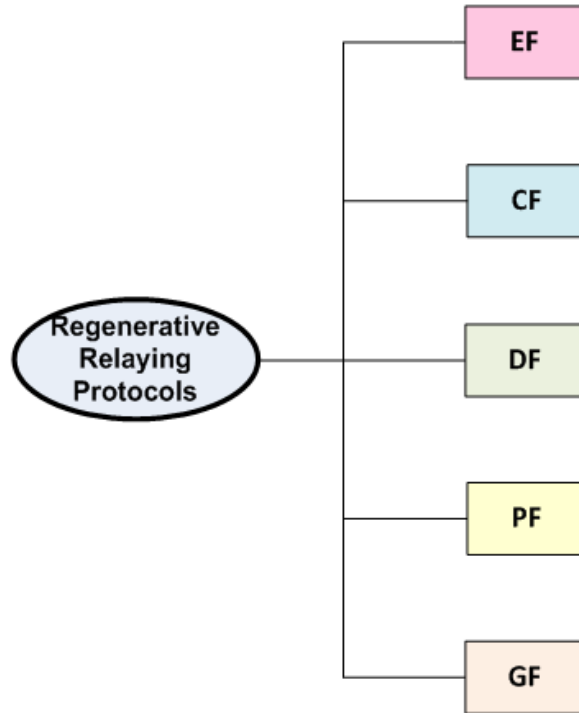

Figure 3.5: *Example protocols belonging to the Regenerative relaying*

- **Estimate and Forward (EF):** The analog signal is amplified and down-converted to baseband, after which some detection algorithms aim at recovering the original representation of the signal. This estimate is then retransmitted. For instance, the EF relay estimates the modulated symbol and retransmits its estimate using the same or a different modulation order.
- **Compress and Forward (CF):** This protocol is similar to the above EF protocol in that it relays a compressed version of the detected information stream to the destination. This involves some form of source coding on the sampled signal samples and was shown to be capacity/performance optimum for the compressing node being close to the destination.
- **Decode and Forward (DF):** Being the prominent counter protocol to the transparent AF protocol, DF detects the signal, decodes it and re-encodes it prior to retransmission. A vast amount of different DF protocols exists today. Over a wide gamut of application scenarios, DF is known to be performance optimum w.r.t. typical metrics such as error rate.
- **Purge and Forward (PF):** Modern communication systems are usually designed to be interference rather than noise limited. This design principle also applies to cooperative systems where PF allows for interference between the different relaying streams and deals with it by eliminating as much of it as possible at each relay node.
- **Gather and Forward (GF):** Also sometimes referred to as aggregate and forward protocol, this protocol is an extension to CF in that a relay node not only performs

source coding over the sampled information but also on the information itself, which is aggregated over a few communication slots.

The main difference between compress-and-forward and the two most common techniques, decode/amplify-and-forward is that while in the later the relay transmits a copy of the received message, in compress-and-forward the relay transmits a quantized and compressed version of the received message. Therefore, the destination node will perform the reception functions by combining the received message from the source node and its quantized and compressed version from the relay node [26].

3.2 Canonical Information Flows

From the above-discussed node behaviors, relaying protocols, duplexing and access methods, we can construct different information flows and architectures, some of which have already been discussed. Subsequent discussions relate to the case of a noncooperative single source, single destination systems only; the extension to the case of cooperation, multiple sources and destination follows the same recipe [8].

- **Direct Link:**Information from a source can of course reach the destination by means of a single direct link.
- **Serial Relaying:**As per figure 3.6, serial relaying connects the source and the destination by means of a chain of relays that are assumed to use orthogonal channels to relay the information. Note that in this and subsequent cases a direct link may or may not be available.

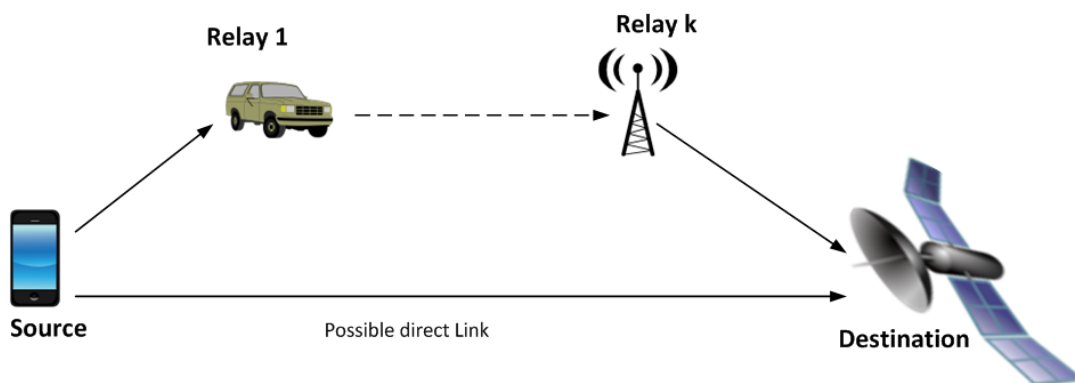

Figure 3.6: *Canonical network information flow by means of Serial relaying*

- **Parallel Relaying:**As per figure 3.7, parallel relaying connects the source and the destination by means of a parallel set of relays that are assumed to use orthogonal channels to relay the information at the same time.

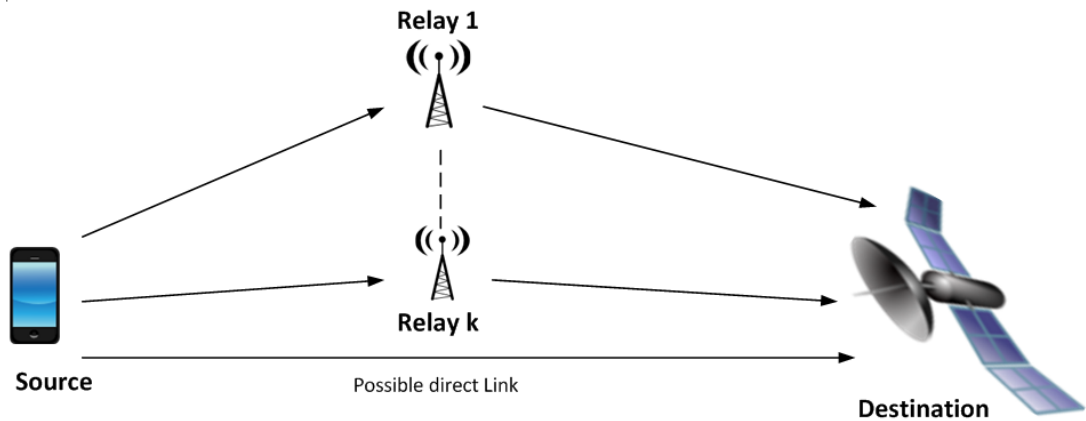

Figure 3.7: *Canonical network information flow by means of Parallel relaying*

- **Space-Time Relaying:** As per figure 3.8, space-time relaying connects the source and the destination by means of a parallel set of relays that are assumed to use space-time encoded channels to relay the information.

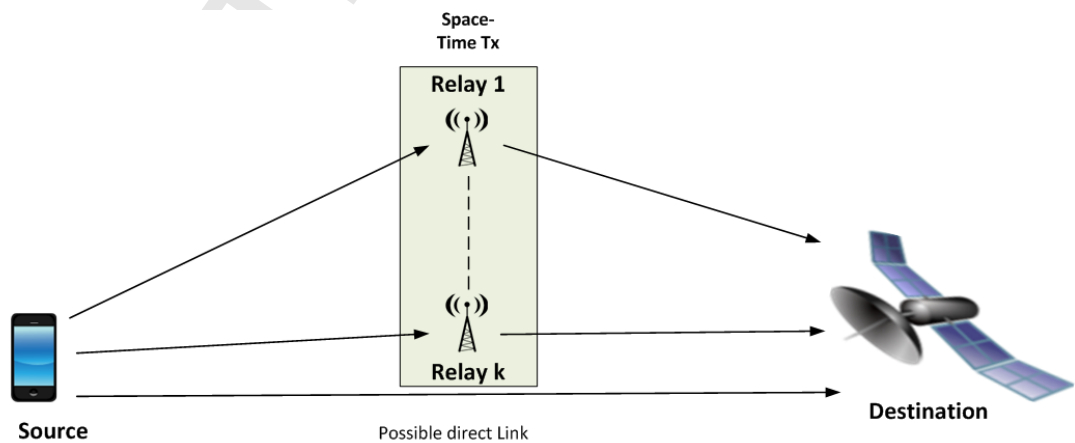

Figure 3.8: *Canonical network information flow by means of Space-Time relaying*

- **Composites Thereof:** As per figure 3.9, an information flow can be realized by building hybrids from the above-discussed relaying methods.

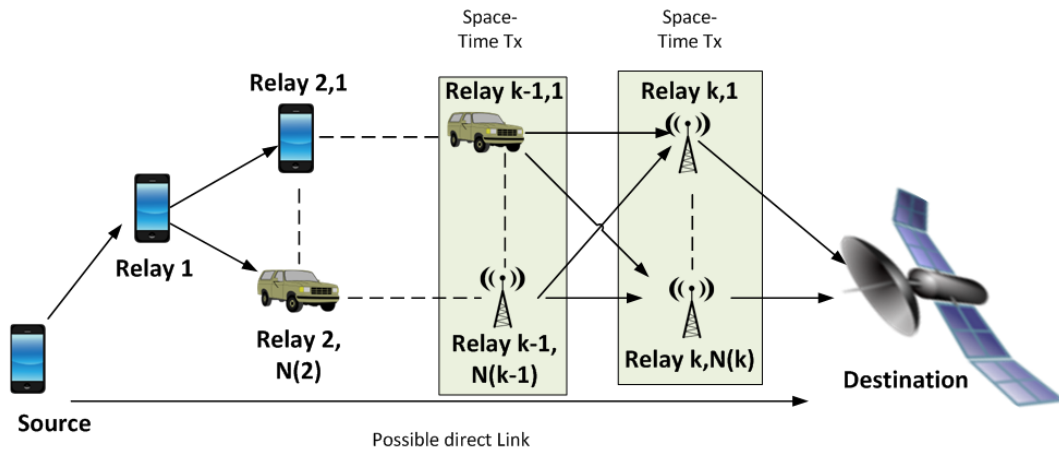

Figure 3.9: *Canonical network information flow by means of hybrids thereof*

Chapter 4

Satellite Communications

4.1 Introduction

Satellite communications is one of the most impressive spinoffs from the space programs and has made a major contribution to the pattern of international communications. A communication satellite is basically an electronic communication package placed in orbit whose prime objective is to initiate or assist communication transmission of information or message from one point to another through space. The information transferred most often corresponds to voice (telephone), video (television), and digital data.

Communication satellites may involve other important communication subsystems as well. In this instance, the satellites need to be monitored for position location in order to instantaneously return an upwardly transmitting (uplink) ranging waveform for tracking from an earth terminal (or station) [22].

4.1.1 The origin of Satellites

The Space Age began in 1957 with the U.S.S.R.'s launch of the first artificial satellite, called *Sputnik*, which transmitted telemetry information for 21 days. This achievement was followed in 1958 by the American artificial satellite *Score*, which was used to broadcast President Eisenhower's Christmas message. Two satellites were deployed in 1960: a reflector satellite, called *Echo*, and *Courier*. The *Courier* was particularly significant because it recorded a message that could be played back later. In 1962 active communication satellites (repeaters), called *Telstar* and *Relay*, were deployed, and the first geostationary satellite, called *Syncom*, was launched in 1963. The race for space exploitation for commercial and civil purposes thus truly started.

A satellite is geostationary if it remains relatively fixed (stationary) in an apparent position relative to the earth. This position is typically about 35,784 km away from the earth. Its elevation angle is orthogonal (i.e., 90°) to the equator, and its period of revolution is synchronized with that of the earth in inertial space. A geostationary satellite has also been called a *geosynchronous* or *synchronous* orbit, or simply a *geosatellite*.

The first series of commercial geostationary satellites was inaugurated in 1965. These satellites provided video (television) and voice (telephone) communications for their audiences. Intelsat was the first commercial global satellite system owned and operated by a consortium of more than 100 nations; hence its name, which stands for *International*

Telecommunications Satellite Organization. The first organization to provide global satellite coverage and connectivity, it continues to be the major communications provider with the broadest reach and the most comprehensive range of services.

Other providers for industrial and domestic markets include *Westar* in 1974, *Satcom* in 1975, *Comstar* in 1976, *SBS* in 1980, *Galaxy and Telstar* in 1983, *Spacenet and Anik* in 1984, *Gstar* in 1985, *Aussat* in 1985-86, *Optus A2* in 1985, *Hughes-Ku* in 1987, *NASA ACTS* in 1993, *Optus A3* in 1997, and *Iridium* and *Intelsat VIIIA* in 1998. Even more are planned. Some of these satellites host dedicated military communication channels. The need to have market domination and a competitive edge in military surveillance and tactical fields results in more sophisticated developments in the satellite field [22].

4.1.2 Types of Satellites

There are, in general, four types of satellite [22]:

- Geostationary satellite (GEO)
- High elliptical orbiting satellite (HEO)
- Medium-earth orbiting satellite (MEO)
- Low-earth-orbiting satellite (LEO)

An HEO satellite is a specialized orbit in which a satellite continuously swings very close to the earth, loops out into space, and then repeats its swing by the earth. It is an elliptical orbit approximately 18,000 to 35,000 km above the earth's surface, not necessarily above the equator. HEOs are designed to give better coverage to countries with higher northern or southern latitudes. Systems can be designed so that the apogee is arranged to provide continuous coverage in a particular area. By definition, an apogee is the highest altitude point of the orbit, that is, the point in the orbit where the satellite is farthest from the earth.

MEO is a circular orbit, orbiting approximately 8,000 to 18,000 km above the earth's surface, again not necessarily above the equator. MEO satellite is a compromise between the lower orbits and the geosynchronous orbits. MEO system design involves more delays and higher power levels than satellites in the lower orbits. However, it requires fewer satellites to achieve the same coverage.

LEO satellites orbit the earth in grids that stretch approximately 160 to 1,600 km above the earth's surface. These satellites are small, are easy to launch, and lend themselves to mass production techniques. A network of LEO satellites typically has the capacity to carry vast amounts of facsimile, electronic mail, batch file, and broadcast data at great speed and communicate to end users through terrestrial links on ground-based stations. With advances in technology, it will not be long until utility companies are accessing residential meter readings through an LEO system or transport agencies and police are accessing vehicle plates, monitoring traffic flow, and measuring truck weights through an LEO system.

4.1.3 Communications via Satellite

Radiowaves, suitable as carriers of information with a large bandwidth, are found in frequency ranges where the electromagnetic waves are propagated through space almost in conformity with the law of optics, so that only line-of-sight radio communication is possible. As a result, topographical conditions and the curvature of the earth limit the length of the radio path. Relay stations, or repeaters, must be inserted to allow the bridging of greater distances (see figure 4.1). Skyway radar uses the ionosphere, at height of 70 to 300 km, to transmit information beyond the horizon and may not require repeaters. However, transmission suffers from ionospheric distortions and fading. To ensure that appropriate frequencies are optimally selected, additional monitoring equipment is required to sample the ionospheric conditions instantaneously.

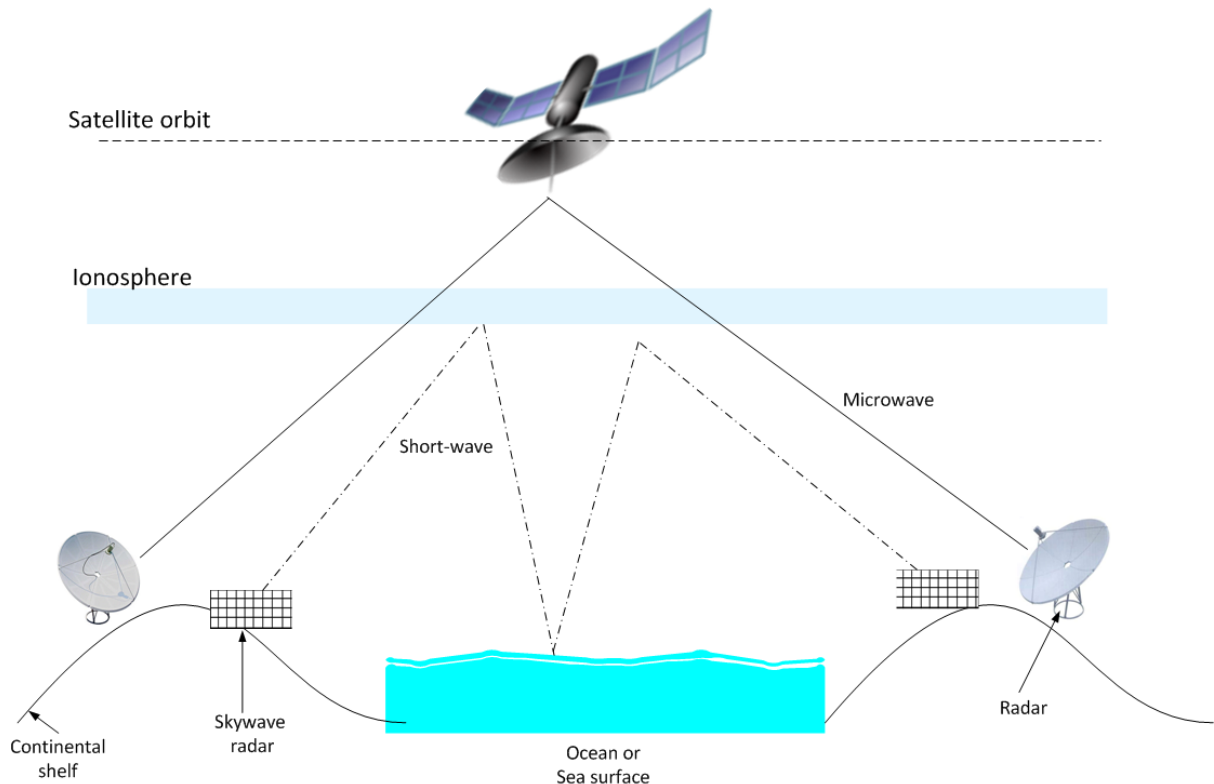

Figure 4.1: *Intercontinental communication paths*

A communication satellite in orbit around the earth exceeds the latter requirement. Depending on the orbit's diameter, satellites can span large distances almost half the earth's circumference. However, a communication link between two subsystems - for instance, earth stations or terminals - via the satellite may be considered a special case of radio relay, as shown in figure 4.2, with a number of favorable characteristics:

- A desired link between two terminals in the illumination zone can be established.
- The investment for a link in the illumination zone is independent of the distance between the terminals.

- A provision for wide-area coverage for remote or inaccessible territories or for new services is made.
- This is ideally suited to medium, point-to-multiunit (broadcast) operations.

A practical satellite comprises several individual chains of equipment called a transponder: a term derived from transmitter and responder. Transponders can channel the satellite capacity both in frequency and in power. A transponder may be accessed by one or several carriers. Transponders exhibit strong nonlinear characteristics and multicarrier operations, unless properly balanced, which may result in unacceptable interference [22].

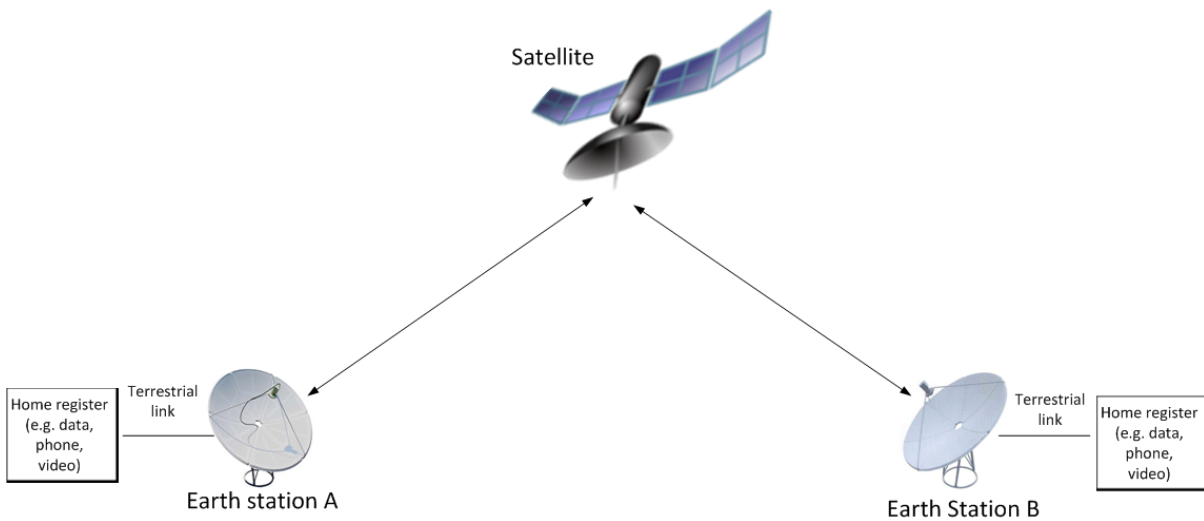

Figure 4.2: *Communication between two earth stations via satellite*

4.1.4 Characteristic features of communication satellites

Satellite communication circuits have several characteristic features. These include [22]:

1. Circuits that traverse essentially the same radiofrequency (RF) pathlength regardless of the terrestrial distance between the terminals.
2. Circuits positioned in geosynchronous orbits may suffer a transmission delay t_d , of about 119ms between an earth terminal and the satellite, resulting in a user-to-user delay of 238 ms and an echo delay of 476ms

For completeness, transmission delay is calculated using

$$t_d = \frac{h_0}{c} \quad (4.1)$$

where h_0 is the altitude above the subsatellite point on the earth terminal and c is the speed of light $c = 3 \times 10^8 \text{ m/sec}$. For example, consider a geostationary satellite whose altitude h_0 above the subsatellite point on the equator is 35,784 km.

This gives a one-way transmission delay of 119 msec, or a roundtrip transmission delay of 238 msec. It should be noted that an earth terminal not located at the subsatellite point would have greater transmission delays.

3. Satellite circuits in a common coverage area pass through a single radiofrequency (RF) repeater for each satellite link. This ensures that earth terminals, which are positioned at any suitable location within the coverage area, are illuminated by the satellite antenna(s). The terminal equipment could be fixed or mobile on land or mobile on ship and aircraft.
4. Although the uplink power level is generally high, the signal strength or power level of the received downlink signal is considerably low because of
 - High signal attenuation due to free-space loss
 - Limited available downlink power
 - Finite satellite downlink antenna gain, which is dictated by the required coverage area

For these reasons, the earth terminal receivers must be designed to work at significantly low RF signal levels. This leads to the use of the largest antennas possible for a given type of earth terminal and the provision of low-noise amplifiers (LNA) located at close proximity to the antenna feed.

5. Messages transmitted via the circuits are to be secured, rendering them inaccessible to unauthorized users of the system. Message security is a commerce closely monitored by the security system designers and users alike. For example, Pretty Good Privacy (PGP), invented by Philip Zimmerman, is an effective encryption tool. The U.S. government sued Zimmerman for releasing PGP to the public, alleging that making PGP available to enemies of the United States could endanger national security. Although the lawsuit was later dropped, the use of PGP in many other countries is still illegal.

4.2 Multibeam systems

Multibeam satellite systems have been inspired by the success of the cellular paradigm, which allows carefully planned frequency reuse while keeping intercell interference within acceptable limits to achieve high spectral efficiency. In addition, the demand for interactive data services on top of broadcasting has supported the implementation of multibeam systems, which allow for finer partitioning of the coverage area and independent stream transmission within each beam. So, current satellite systems, following the cellular paradigm, employ multiple antennas (i.e. multiple onboard antenna feeds) to divide the coverage area into small beams (spotbeams). In addition, the demand for interactive data services on top of broadcasting has supported the implementation of multibeam systems, which allow for finer partitioning of the coverage area and independent stream transmission within each beam.

A large number of spotbeams can be employed to cover the same coverage area contrary to recent satellite technology where a single (global) beam is employed. Currently,

tens or hundreds of beams are possible with a typical reuse factor of four. However, due to the antenna design, the beam patterns partially overlap on the ground creating interbeam interference. The beam patterns and the corresponding allocated power have to be carefully designed to ensure that interbeam interference stays within acceptable limits, which are determined by the carrier to interference ratio of the beamedge users. A similar effect has been limiting the performance of terrestrial cellular networks for decades, but has been alleviated based on multicell joint processing, where user signals in the downlink channel are jointly precoded before being transmitted by neighboring BS antennas in order to mitigate inter-cell interference. However, one of the practical obstacles in terrestrial implementation is the requirement of a backhaul network which enables the cooperation amongst neighboring BSs.

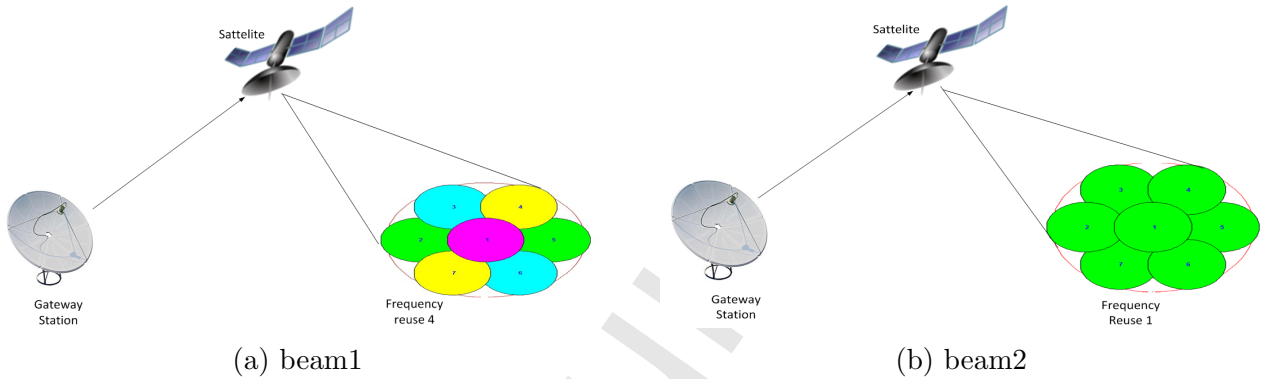

Figure 4.3: *Left: Conventional 4-color frequency reuse scheme. Right: Multibeam joint precoding paradigm using full frequency reuse.*

The principle of multibeam joint processing can be applied to multibeam satellite systems. As illustrated in Figure 4.3, instead of being served by only one beam, each user's signal is precoded at the gateway (GW) and sent by all beams. The main implementation advantage over terrestrial wireless systems is that usually the signals for adjacent beams are transmitted from the same GW through the satellite to the users in the forward link (FL), as a result, joint precoding can take place at that GW and there is no need for expensive backhauling. When multiple GWs serve clusters of beams, distributed joint precoding techniques can be employed, but here we focus on one cluster of beams served by a single GW. To mitigate interference among multibeams, spatial processing and specifically effective precoding techniques can be exploited, which jointly pre-processes data to all beams at the GW [45].

To the end of limiting interbeam interferences, these multibeam satellite communication (SatCom) systems spatially separate beams that share the same bandwidth. This multibeam architecture allows for a significant boost in capacity by reusing the available spectrum several times within the coverage area, especially in the Ka-band. Subsequently, the capacity of current satellite systems can well exceed 100 GBps with state-of-the-art architectures. A large number of recent satellite systems procurements have clearly confirmed the trend towards multibeam satellite systems as broadband reference system architecture. Examples include systems such as Wildblue-1 and Anik F2 (66 Ka-band spot beams), Kasat (82 Ka-band spot beams) and recently Viasat-1 (72 spot

beams in Ka-band) for mainly fixed two-way (i.e., interactive) broadband applications as well as the GlobalExpress system designed for a new generation of mobile services in Ka-band. Interactive services, in particular, benefit from these architectures since a finer partitioning of the coverage area allows for parallel data stream transmissions.

Despite the achievements of current SatComs, existing systems are far from the future goals for terabit capacity. Two main obstacles towards the Terabit satellite are namely the internal with respect to the system interferences (i.e., intrasystem or interbeam interferences) and the overwhelming number of spotbeams needed to achieve Terabit throughput. To alleviate these performance constraints, novel techniques need to be explored.

Terrestrial systems, have introduced the paradigm of multicell joint processing to mitigate interferences and boost system capacity. According to this paradigm, user signals received in the uplink channel by neighboring base station (BS) antennas are jointly decoded in order to mitigate intercell interferences. Similarly, user signals in the downlink channel are jointly precoded before being transmitted by neighboring BS antennas for the same purpose. However, one of the practical obstacles in joint processing implementation is the existence of a backhaul network which enables this form of cooperation amongst neighboring BSs.

The interference limited nature of the multibeam satellite channel is a commonality between SatCom and terrestrial systems. Also, considering the architecture of multibeam SatComs networks, a small number of ground stations is responsible for processing the transmitted and received signals that correspond to a vast coverage area. This characteristic simplifies the application of joint processing techniques[5].

4.2.1 Joint Processing in SatComs

A multibeam satellite operates over an interference limited channel, for which the optimal communication strategy in general is not yet known. Hence, orthogonalization in the frequency and polarization domain is used to limit interbeam interferences. However, the concept of multibeam joint processing can be applied and the system can benefit from reusing the full frequency in all beams [5].

Multibeam Joint Processing in the Forward Link

In the context of SatComs, multibeam joint processing scenarios have been studied in various settings. Specifically, the FL case has been examined. Various characteristics of the multibeam satellite channel were taken into account such as beam gain, rain fading , interference matrix and correlated attenuation areas. Joint processing studies concerning the FL of SatCom systems usually assume fixed users. This assumption originates from the difficulties in acquiring reliable and up to date CSI for the FL of satellite systems. During the CSI acquisition process, the pilot signals need to be broadcasted to the users and then fed back to the transmitter, thus doubling the effect of the long propagation delay of the satellite channel and rendering the acquired CSI outdated. Subsequently, the adoption of the slow fading channel of the fixed satellite services (FSS), partially alleviates this obstacle since CSI needs to be updated less frequently[5].

Multibeam Joint Processing in the Return Link

First attempts to study multibeam joint processing in the Return Link RL, onwards referred to as multi-beam joint decoding, have been carried out. The RL of a satellite system employing multibeam joint decoding was studied via simulations from a system point of view, where MMSE and optimal multiuser receivers were considered, on a simplistic channel model basis, demonstrating a considerable improvement in both availability and throughput. The first analytic investigation of the uplink capacity of a multibeam satellite system was done , where closed-form expressions were derived for the capacity of multibeam Rician channels. Asymptotic analysis methods for the eigenvalues of the channel matrix were used to determine upper bounds for the ergodic capacity and calculate the outage probability of a MIMO Land Mobile channel (LMS) which is represented by Rician fading with a random line-of-sight (LoS) component. Similarly, the statistics of minimum and maximum eigenvalues were derived for Rician fading with Gamma distributed LoS component. Finally, it should be noted that a multiuser decoding algorithm was presented[5].

4.2.2 Multibeam Satellite Network- Advantages

Multibeam antennas carried aboard the satellites attempt to conserve available frequencies. A multibeam antenna transmits a family of pencil-thin beams, often so small that, by the time they reach the earth's surface, their footprint covers an oval only a few tens of kilometers wide. As an illustration, instead of using a global angular width of 17.33° for one satellite for a global beam coverage, multiple narrow beams, each of an angular width of 1.73° with reduced coverage and increased gain, are used. This scheme permits multibeam satellite configuration. This scheme includes the following advantages [22]:

- Power is divided among the beams, and the bandwidth remains constant for each beam. As a result, the total bandwidth increases by the number of beams.
- Performance improves as the number of beams increases although limited by technology and the complexity of the satellite, which increases with the number of beams.
- There is extended satellite coverage from the juxtaposition of several beams, and each beam provides an antenna gain that increases as the angular beamwidth decreases.
- Frequency reuse is achieved, which means using the same frequency band several times so as to increase the overall capacity of the network without increasing the allocated bandwidth. This can be achieved by exploiting the isolation resulting from antenna directivity to reuse the same frequency band in different beams. For instance, an antenna designed to transmit or receive an electromagnetic wave of a given polarization can neither transmit nor receive in the orthogonal polarization. This property enables two simultaneous links to be established at the same frequency between two identical locations. This process is called frequency reuse or orthogonal polarization. To achieve this feat, either two polarized antennas must be

provided at each end or, preferably, one antenna, which operates with the two specified polarizations, may be used. The drawback is that this could lead to mutual interference of the two links.

4.3 Satellite component of NGN: Integrated and Hybrid networks

Satellites are successful for their wide area coverage and speed to provide new services. Niche areas such as coverage for planes and ships will persist, but land masses convergence of fixed, mobile, and broadcasting systems will dictate that the only way forward for satellite networks is in an integrated format with terrestrial systems. Today the interest for global cellular networks is to define new systems, integrating segments offering differentiated coverage such as indoor, outdoor, and global.

The satellite network is mostly immune to terrestrial events, but mainly relies on Line-Of-Sight (LOS) communications and this could be a significant limit. This is the reason why an integrated/hybrid network has to be considered with terrestrial wireless systems cooperating with the satellite one. This telecommunication infrastructure needs to be quickly deployable, scalable, reconfigurable, and must manage efficient interworking and user mobility.

The convergence of mobile and Internet technologies is now paving the way to the development of systems capable of supporting multimedia and interactive services previously available only to fixed users. International Telecommunication Union (ITU) is currently developing a vision of Next-Generation Networks (NGN) with the clear objective of providing a means for true network integration. The purpose of this integration is effective utilization of the respective strengths of each network, within the context of their traditional roles and mandates. These integrated and hybrid systems enable an NGN by seamlessly interworking and cooperatively combining the most powerful aspects of satellite and terrestrial networks, according to the Always Best Connected (ABC) paradigm. In particular, the satellite network can provide the best and most comprehensive coverage for low-density populations, while the terrestrial network or the ground component can provide the highest bandwidth and lowest cost coverage for high-density populations in urban environments.

The main difference between integrated and hybrid systems is on whether both space and terrestrial parts use a common network and spectrum. The terrestrial part of an integrated system is a complementary part of the satellite system, and thus it uses the same frequency band allocated to the satellite system and also it is operated by the same network. Such systems are referred to as MSS-ATC (MSS-Ancillary Terrestrial Component) in the United States and Canada, and MSS-CGC (MSS-Complementary Ground Component) in Europe and are implemented in the 1-3GHz bands. On the other hand, a hybrid system may combine a satellite system with a terrestrial one with different frequency bands, networks, and even air interfaces [23].

4.3.1 Background

Primitive versions of these systems can be found in mobile satellite broadcasting services to handheld terminals, although they are Broadcasting Satellite Services (BSS) instead of MSS. More recently, in Korea and Japan, Satellite-Digital Multimedia Broadcasting (S-DMB) service to hand-held user terminals was successfully deployed via a geostationary (GEO) satellite. In Europe, the Mobile Digital broadcast Satellite (MoDiS) project implemented an S-DMB experimental platform where transparent terrestrial repeaters were adopted. Moreover, “Unlimited Mobile TV” concept was introduced, in which a hand-held mobile terminal is supposed to receive broadcast signals from both satellite and terrestrial repeaters. 3GPP has introduced the Multimedia Broadcast and Multicast Service (MBMS) concept into 3G/beyond-3G networks: we can expect an integrated scenario where the satellite cooperates with the UMTS terrestrial segment to provide mobile users with MBMS services.

The multi-segment nature of the broadcast service entails the adoption of suitably new multicast routing schemes. Media companies require prompt multicast of extremely large files from a single source to a collection of geographically dispersed destinations. In addition to this, there is the emerging application of digital cinema, a digital technology to distribute geographically a movie via satellite and to project it.

One of the main characteristics of the ETSI Broadband Satellite Multimedia (BSM) standard architecture is allowing services and networks to be realized and offered separately and without any dependence. This approach is very suitable to support integrated and hybrid networks. The key element of this standard is the SI-SAP (Satellite-Independent Service Access Point) interface between satellite technology-dependent layers (i.e. OSI layers 1 and 2) and the higher layers that are satellite technology-independent [23].

4.3.2 Integrated/hybrid systems (Definition and architecture)

Integrated systems

ITU defined “an integrated Mobile Satellite Service (MSS) system” as a system employing MSS and a ground component where the ground component is complementary to and operates as part of the MSS system and, together with the satellite component, provides an integrated service offering. In such systems, the ground segment is controlled by the satellite resource and network management system. Further, the ground component uses the same designated portions of the frequency band as the associated operational MSS system.

An integrated system provides a combined (integrated) single network that uses both a traditional MSS link and terrestrial transmission paths to serve mobile end-users. With proper network planning and control of both the space and terrestrial segments of the system, the operators can use the assigned spectrum extensively and efficiently to provide indoor and outdoor coverage in urban, suburban, rural, and remote areas, including direct satellite service to small handsets. A typical integrated system comprises one or more multi-spot beam satellites and a nation-wide or regional ensemble of terrestrial cell sites, where both terrestrial and space components communicate with mobile terminals using a common set of MSS frequencies. The global “umbrella” coverage is supplied by the

satellite systems, mainly based on GEO satellites.

The resource allocation has to be coordinated between the terrestrial and the satellite segment, where the terrestrial part is based on 2G/3G/3G1/LTE cellular systems and where satellite and terrestrial coverages are in overlap or complementary. Radio resources of the satellite segment are precious and costly [23].

Hybrid systems

ITU defined “a hybrid satellite and terrestrial system” as employing satellite and terrestrial components where the satellite and terrestrial systems are interconnected, but operate independently of each other. In such systems, satellite and terrestrial components have separate network management systems and do not necessarily operate in the same frequency band. The hybrid system utilizes a satellite component that is part of either an FSS or an MSS network and the terrestrial component operates in a fixed, mobile or nomadic mode.

Hybrid networking calls for different segments to be involved together in service delivery, where the terrestrial component is based on a Wireless Local Area Network (WLAN), for instance, WiFi or WiMAX, having complementary coverage with respect to the satellite system. The inter-working of QoS mechanisms is a critical aspect in hybrid systems: each segment should have QoS support mechanisms with end-to-end consistent choices [23].

4.4 Channel- differences with terrestrial

Multimedia broadcast and multicast services (MBMS) will play an important role in future mobile systems, and a satellite system is a very effective way to provide these services due to its wide area coverage, reconfigurability, and multicast capabilities. Adaptive transmissions, including power control and adaptive modulation and coding (AMC), have become critical techniques for all wireless systems. Their purpose is to regulate the transmitting resources in such a way that the signal received has the required signal-to noise ratio (SNR) with the minimum energy consumption. The time varying characteristics of wireless mobile channels necessitate adaptive radio interfaces in order to provide high-quality and economic services.

Because satellite bandwidth is a relatively scarce resource, adaptive usage of the resources offered by the various modulation and coding schemes is mandatory for a system’s efficiency and economy. Examples can be found in many future communication standards, including digital video broadcasting via satellite (DVB-S2). However, the performance enhancement gleaned from these kinds of techniques can only be guaranteed when precise channel quality information (CQI) from the return link is available at the transmitter. The unidirectional nature of MBMS prohibits the use of control commands for power control and AMC. Therefore, in this situation the downlink strategies should be focused on improving the performance. Here, we introduce a downlink transmission technique that can be used to improve the system performance for satellite MBMS.

This approach is to use space-time coding (STC) in order to make use of the diversity gain introduced into the signals from the different antennas by temporal and spatial correlation. This STC technique enables diversity gains to be obtained from multiple

paths without increasing the total transmitted power or transmitted bandwidth. In addition, it does not require any CQI at the transmitter. In the next section we introduce a transmit diversity technique applied to hybrid satellite-terrestrial networks (HSTNs), in which a satellite and several terrestrial repeaters, each with a single antenna, operate in unison to send space-time encoded signals so that the receiver may realize diversity gains [21].

4.4.1 Satellite with terrestrial system

STC enjoys several advantages that make it very attractive for high-rate wireless applications. Using several antennas definitely gives rise to transmit diversity gain in the terrestrial system, where it is possible to assume that the path components from other antennas are independent. On the other hand, it is difficult to expect the same gain to be achieved in a satellite system, because the distance between the satellite and the user terminal is much longer than that among the antennas, so each path seems to be similar. In the HSTN, however, we can still obtain diversity gains by using the signal paths from the satellite and/or those from the terrestrial repeaters. At a user terminal in the hybrid network, the signals from the satellite and those from the repeaters will be independent of each other. In this situation the antennas are no longer collocated at the transmitter or receiver, but rather are distributed at relay stations, which cooperate in order to construct the STC transmission [21].

4.4.2 Satellite with terrestrial relay

The demand for high bit rate transmission supporting a variety of multimedia services is increasing day by day. Satellite technology can address this concern as it can be used to develop a global communication system. In this scenario, the differences between terrestrial and satellite communication systems as well as between fixed and mobile networks will cease to exist in the global coverage by wireless communication system.

Cooperative relaying networks are useful in the satellite-terrestrial networks as it can extend the satellite coverage especially in the areas where terrestrial networks are not able to provide services due to lack of coverage, emergency conditions, and network overloads. Many efficient physical layer techniques like adaptive coding and modulation (ACM), satellite channel modeling, synchronization and estimation are proposed, but these techniques are not able to provide satellite coverage inside buildings and shopping malls due to lack of signal from the satellites. In such situations, a cooperative relaying satellite-terrestrial network can play an important role as it offers services inside covered areas as well as supports low cost user terminals with satellite transmission and reception capabilities. The relay node operates in two strategies, i.e. Amplify and Forward (AF), and Decode and Forward (DF). Hence, diversity gain can be achieved through multiple signal paths. As a result, a high data rate is achieved and transmission becomes more reliable in terms of symbol error rate (SER) and outage probability. Many standardization groups have incorporated relaying techniques into their emerging standards such as IEEE 802.16 and IEEE 802.11.

In a cooperative relaying satellite-terrestrial system, a hybrid channel consisting of satellite and terrestrial components is perceived by the destination node. Furthermore,

the conventional channel models used in terrestrial radio propagation cannot be used to characterize the satellite channel because of the remarkable differences observed in the line-of-sight (LOS) and shadowing links. In order to model such a satellite channel, a combination of different probability distributions is necessary. A hybrid satellite-terrestrial channel is considered in which fadings in the source(satellite)-relay (S-R) and source(satellite)-destination (S-D) links are assumed to be Rician distributed, while Rayleigh fading is assumed between the relay-destination (R-D) link [13].

Πανεπιστήμιο Πειραιώς

Chapter 5

Terrestrial Relays in MIMO Multibeam Satellite System

5.1 System model

We consider an amplify-and-forward (AF), multirelay and single user MIMO system with full-duplex relays. An outline system model is given by the next figure 5.1.

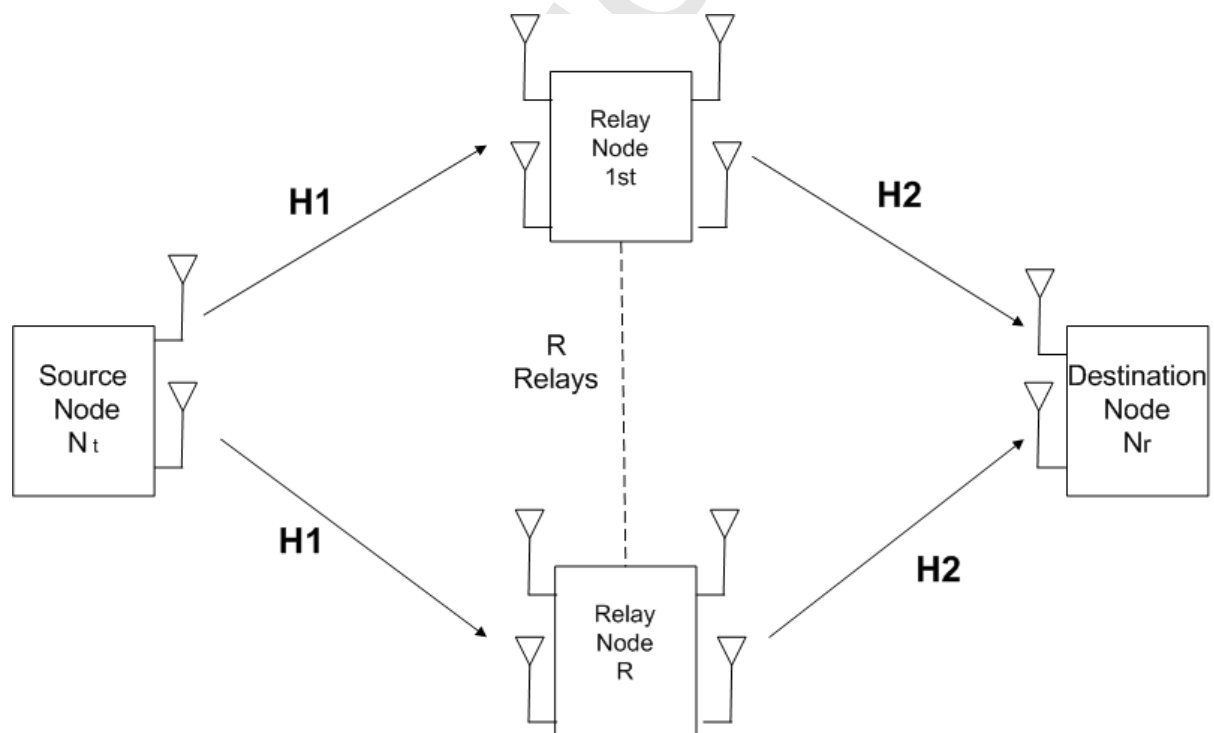

Figure 5.1: *System Model*

The system comprises R intermediate relay nodes which lie between source and destination nodes that have N_t and N_r antennas, respectively. Likewise, we have only one user in the source and the destination node. Each relay has M_r and M_t receive and transmit antennas respectively. The transmitted data consists of N_t independent data streams which are allocated to the correspondingly numbered antennas at the source and

relay nodes. The source node transmits to the relay nodes and the relay nodes amplify and forward their received signal to the destination. Assuming that $M_r = M_t = M$, the $1 \times (M_r * R)$ received signal at the relays is given by

$$\mathbf{y}_1 = \mathbf{H}_1 * \mathbf{x} + \mathbf{n}_R \quad (5.1)$$

The matrix \mathbf{H}_1 is the $N_t \times (N_r * R)$ source-relays channel matrix. The quantity \mathbf{n}_R is a vector of zero mean additive white Gaussian noise with the same dimensions as the corresponding received signal. So, $1 \times (M_r * R)$ is the dimension of \mathbf{n}_R , \mathbf{x} is the $1 \times N_t$ data vector.

The $1 \times N_r$ received signal at the destination from the relays is given by

$$\mathbf{y}_2 = \mathbf{H}_2 * a * \mathbf{y}_1 + \mathbf{n}_D \quad (5.2)$$

where a is the amplification factor with constant values, the \mathbf{H}_2 matrix is the $(M_r * R) \times N_r$ channel matrix, the \mathbf{y}_1 is the received signal at the relays and the \mathbf{n}_D is a vector of zero mean additive white Gaussian noise with the same dimensions as the corresponding received signal. In this case the dimension is $1 \times N_r$.

The equation (5.2) via equation (5.1) gives:

$$\begin{aligned} \mathbf{y}_2 &= \mathbf{H}_2 * \alpha * \mathbf{y}_1 + \mathbf{n}_D \\ &= \mathbf{H}_2 * \alpha * (\mathbf{H}_1 * \mathbf{x} + \mathbf{n}_R) + \mathbf{n}_D \\ &= \underbrace{\mathbf{H}_2 * \alpha * \mathbf{H}_1}_{\mathbf{H}} * \mathbf{x} + \underbrace{\mathbf{H}_2 * \alpha * \mathbf{n}_R + \mathbf{n}_D}_{\mathbf{n}} \end{aligned} \quad (5.3)$$

So, the received signal in the destination will be:

$$\mathbf{y}_2 = \mathbf{H} * \mathbf{x} + \mathbf{n} \quad (5.4)$$

where $\mathbf{H} = \mathbf{H}_2 * \alpha * \mathbf{H}_1$ and $\mathbf{n} = \mathbf{H}_2 * \alpha * \mathbf{n}_R + \mathbf{n}_D$.

Supposing that we have a multibeam system in which we can add the previous simple system model. The figure 5.2 shows the system model.

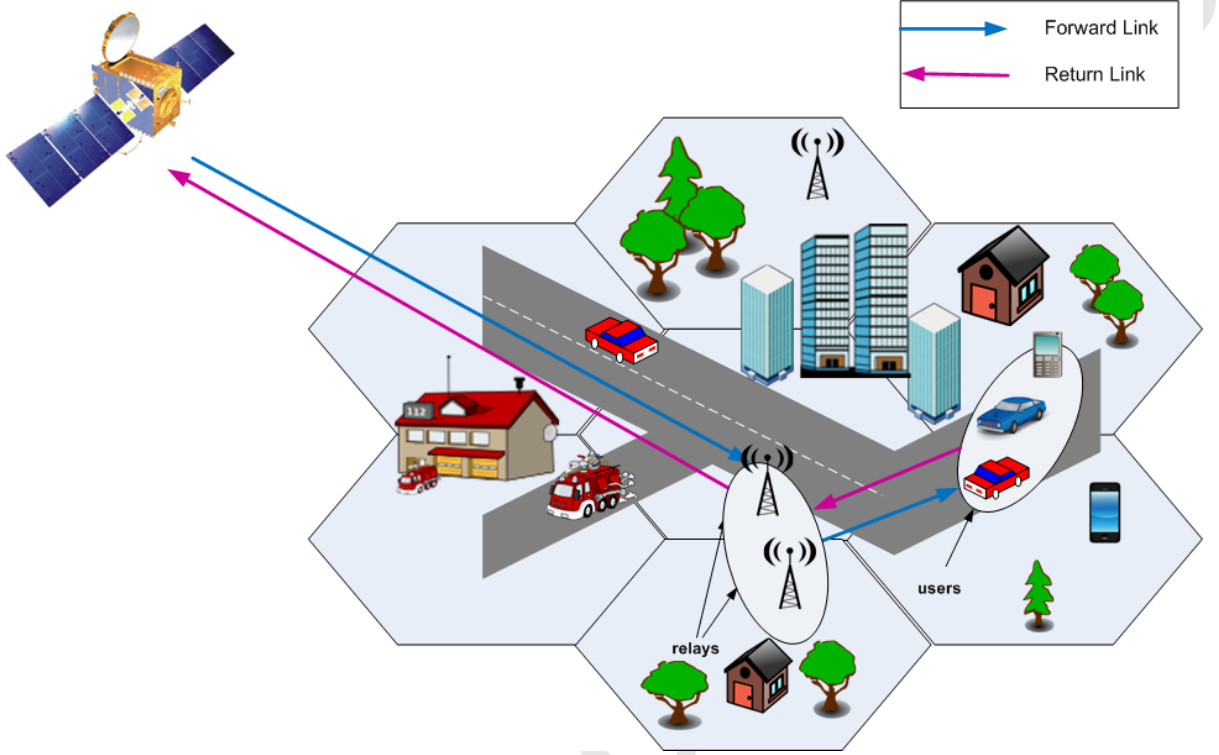
Figure 5.2: *Multibeam System Model*

We focus in the return link but using the simple system model as shown in the beginning of this section.

In the following we use standard linear detection methods. Linear signal detection method treats all transmitted signals as interferences except for the desired stream from the target transmit antenna. Therefore, interference signals from other transmit antennas are minimized or nullified in the course of detecting the desired signal from the target transmit antenna. To facilitate the detection of desired signals from each antenna, the effect of the channel is inverted by a weight matrix \mathbf{W} such that

$$\tilde{\mathbf{x}} = [\tilde{x}_1 \tilde{x}_2 \dots \tilde{x}_{N_t}]^T = \mathbf{W} \mathbf{y}_2 \quad (5.5)$$

that is, detection of each symbol is given by a linear combination of the received signals. The standard linear detection methods include the zero-forcing (ZF) technique and the minimum mean square error (MMSE) technique.

ZF Signal Detection

The zero-forcing (ZF) technique nullifies the interference by the following weight matrix [4]:

$$\mathbf{W}_{ZF} = (\mathbf{H}^H \mathbf{H})^{-1} \mathbf{H}^H \quad (5.6)$$

where $(\cdot)^H$ denotes the Hermitian transpose operation. In other words, it inverts the effect of channel as

$$\begin{aligned}
\tilde{\mathbf{x}}_{ZF} &= \mathbf{W}_{ZF} \mathbf{y}_2 \\
&= \mathbf{x} + (\mathbf{H}^H \mathbf{H})^{-1} \mathbf{H}^H \mathbf{n} \\
&= \mathbf{x} + \tilde{\mathbf{n}}_{ZF}
\end{aligned} \tag{5.7}$$

where $\tilde{\mathbf{n}}_{ZF} = (\mathbf{H}^H \mathbf{H})^{-1} \mathbf{H}^H \mathbf{n}$.

So, using SVD the post-detection noise power is expressed as

$$\begin{aligned}
\|\tilde{\mathbf{n}}_{ZF}\|_2^2 &= \|(\mathbf{H}^H \mathbf{H})^{-1} \mathbf{H}^H \mathbf{n}\|_2^2 \\
&= \|(\mathbf{V} \boldsymbol{\Sigma}^2 \mathbf{V}^H)^{-1} \mathbf{V} \boldsymbol{\Sigma} \mathbf{U}^H \mathbf{n}\|_2^2 \\
&= \|\mathbf{V} \boldsymbol{\Sigma}^{-2} \mathbf{V}^H \mathbf{V} \boldsymbol{\Sigma} \mathbf{U}^H \mathbf{n}\|_2^2 \\
&= \|\mathbf{V} \boldsymbol{\Sigma}^{-1} \mathbf{U}^H \mathbf{n}\|_2^2
\end{aligned} \tag{5.8}$$

Since $\|\mathbf{Q}\mathbf{x}\|_2^2 = \mathbf{x}^H \mathbf{Q}^H \mathbf{Q} \mathbf{x} = \mathbf{x}^H \mathbf{x} = \|\mathbf{x}\|_2^2$ for a unitary matrix \mathbf{Q} , the expected value of the noise power is given as

$$\begin{aligned}
E \{ \|\tilde{\mathbf{n}}_{ZF}\|_2^2 \} &= E \{ \|\boldsymbol{\Sigma}^{-1} \mathbf{U}^H \mathbf{n}\|_2^2 \} \\
&= E \{ \text{tr} (\boldsymbol{\Sigma}^{-1} \mathbf{U}^H \mathbf{n} \mathbf{n}^H \mathbf{U} \boldsymbol{\Sigma}^{-1}) \} \\
&= \text{tr} (\boldsymbol{\Sigma}^{-1} \mathbf{U}^H E \{ \mathbf{n} \mathbf{n}^H \} \mathbf{U} \boldsymbol{\Sigma}^{-1}) \\
&= \text{tr} (\sigma_n^2 \boldsymbol{\Sigma}^{-1} \mathbf{U}^H \mathbf{U} \boldsymbol{\Sigma}^{-1}) \\
&= \sigma_n^2 \text{tr} (\boldsymbol{\Sigma}^{-2}) \\
&= \sum_{i=1}^{N_t} \frac{\sigma_n^2}{\sigma_i^2} \\
&= \sigma_n^2 \sum_{i=1}^{N_t} \frac{1}{\lambda_i}
\end{aligned} \tag{5.9}$$

MMSE Signal Detection

In order to maximize the post-detection signal-to-interference plus noise ratio (SINR), the MMSE weight matrix is given as

$$\mathbf{W}_{MMSE} = (\mathbf{H}^H \mathbf{H} + \sigma_n^2 \mathbf{I})^{-1} \mathbf{H}^H \tag{5.10}$$

Note that the MMSE receiver requires the statistical information of noise σ_n^2 . Using the MMSE weight in equation (5.10), we obtain the following relationship [4]:

$$\begin{aligned}
\tilde{\mathbf{x}}_{MMSE} &= \mathbf{W}_{MMSE} \mathbf{y}_2 \\
&= (\mathbf{H}^H \mathbf{H} + \sigma_n^2 \mathbf{I})^{-1} \mathbf{H}^H \mathbf{y}_2 \\
&= \tilde{\mathbf{x}} + (\mathbf{H}^H \mathbf{H} + \sigma_n^2 \mathbf{I})^{-1} \mathbf{H}^H \mathbf{n} \\
&= \tilde{\mathbf{x}} + \tilde{\mathbf{n}}_{MMSE}
\end{aligned} \tag{5.11}$$

where $\tilde{\mathbf{n}}_{MMSE} = (\mathbf{H}^H \mathbf{H} + \sigma_n^2 \mathbf{I})^{-1} \mathbf{H}^H \mathbf{n}$. Using SVD again, the post-detection noise power is expressed as

$$\begin{aligned} \|\tilde{\mathbf{n}}_{MMSE}\|_2^2 &= \left\| (\mathbf{H}^H \mathbf{H} + \sigma_n^2 \mathbf{I})^{-1} \mathbf{H}^H \mathbf{n} \right\|^2 \\ &= \left\| (\mathbf{V} \boldsymbol{\Sigma} \mathbf{V}^H + \sigma_n^2 \mathbf{I})^{-1} \mathbf{V} \boldsymbol{\Sigma} \mathbf{U}^H \mathbf{n} \right\|^2 \end{aligned} \quad (5.12)$$

Because $(\mathbf{V} \boldsymbol{\Sigma} \mathbf{V}^H + \sigma_n^2 \mathbf{I})^{-1} \mathbf{V} \boldsymbol{\Sigma} = (\mathbf{V} \boldsymbol{\Sigma} \mathbf{V}^H + \sigma_n^2 \mathbf{I})^{-1} (\boldsymbol{\Sigma}^{-1} \mathbf{V}^H)^{-1} = (\boldsymbol{\Sigma} \mathbf{V}^H + \sigma_n^2 \boldsymbol{\Sigma}^{-1} \mathbf{V}^H)^{-1}$, the noise power in equation (5.12) can be expressed as

$$\begin{aligned} \|\tilde{\mathbf{n}}_{MMSE}\|_2^2 &= \left\| (\boldsymbol{\Sigma} \mathbf{V}^H + \sigma_n^2 \boldsymbol{\Sigma}^{-1} \mathbf{V}^H)^{-1} \mathbf{U}^H \mathbf{n} \right\|^2 \\ &= \left\| \mathbf{V} (\boldsymbol{\Sigma} + \sigma_n^2 \boldsymbol{\Sigma}^{-1})^{-1} \mathbf{U}^H \mathbf{n} \right\|^2 \end{aligned} \quad (5.13)$$

Again by the fact that multiplication with a unitary matrix does not change the vector norm, that is, $\|\mathbf{V} \mathbf{x}\|^2 = \|\mathbf{x}\|^2$, the expected value of equation (5.13) is given as

$$\begin{aligned} E \{ \|\tilde{\mathbf{n}}_{MMSE}\|_2^2 \} &= E \left\{ \left\| (\boldsymbol{\Sigma} + \sigma_n^2 \boldsymbol{\Sigma}^{-1})^{-1} \mathbf{U}^H \mathbf{n} \right\|_2^2 \right\} \\ &= E \left\{ \text{tr} \left((\boldsymbol{\Sigma} + \sigma_n^2 \boldsymbol{\Sigma}^{-1})^{-1} \mathbf{U}^H \mathbf{n} \mathbf{n}^H \mathbf{U} (\boldsymbol{\Sigma} + \sigma_n^2 \boldsymbol{\Sigma}^{-1})^{-1} \right) \right\} \\ &= \text{tr} \left((\boldsymbol{\Sigma} + \sigma_n^2 \boldsymbol{\Sigma}^{-1})^{-1} \mathbf{U}^H E \{ \mathbf{n} \mathbf{n}^H \} \mathbf{U} (\boldsymbol{\Sigma} + \sigma_n^2 \boldsymbol{\Sigma}^{-1})^{-1} \right) \\ &= \text{tr} \left(\sigma_n^2 (\boldsymbol{\Sigma} + \sigma_n^2 \boldsymbol{\Sigma}^{-1})^{-2} \right) \\ &= \sum_{i=1}^{N_t} \sigma_n^2 \left(\sigma_i + \frac{\sigma_n^2}{\sigma_i} \right)^{-2} \\ &= \sum_{i=1}^{N_t} \frac{\sigma_n^2 \sigma_i^2}{(\sigma_i^2 + \sigma_n^2)^2} \\ &= \sigma_n^2 \sum_{i=1}^{N_t} \frac{\lambda_i}{(\lambda_i + \sigma_n^2)^2} \end{aligned} \quad (5.14)$$

OSIC Signal Detection

In general, the performance of the linear detection methods is worse than that of other nonlinear receiver techniques. However, linear detection methods require a low complexity of hardware implementation. We can improve their performance without increasing the complexity significantly by an ordered successive interference cancellation (OSIC) method. It is a bank of linear receivers, each of which detects one of the parallel data

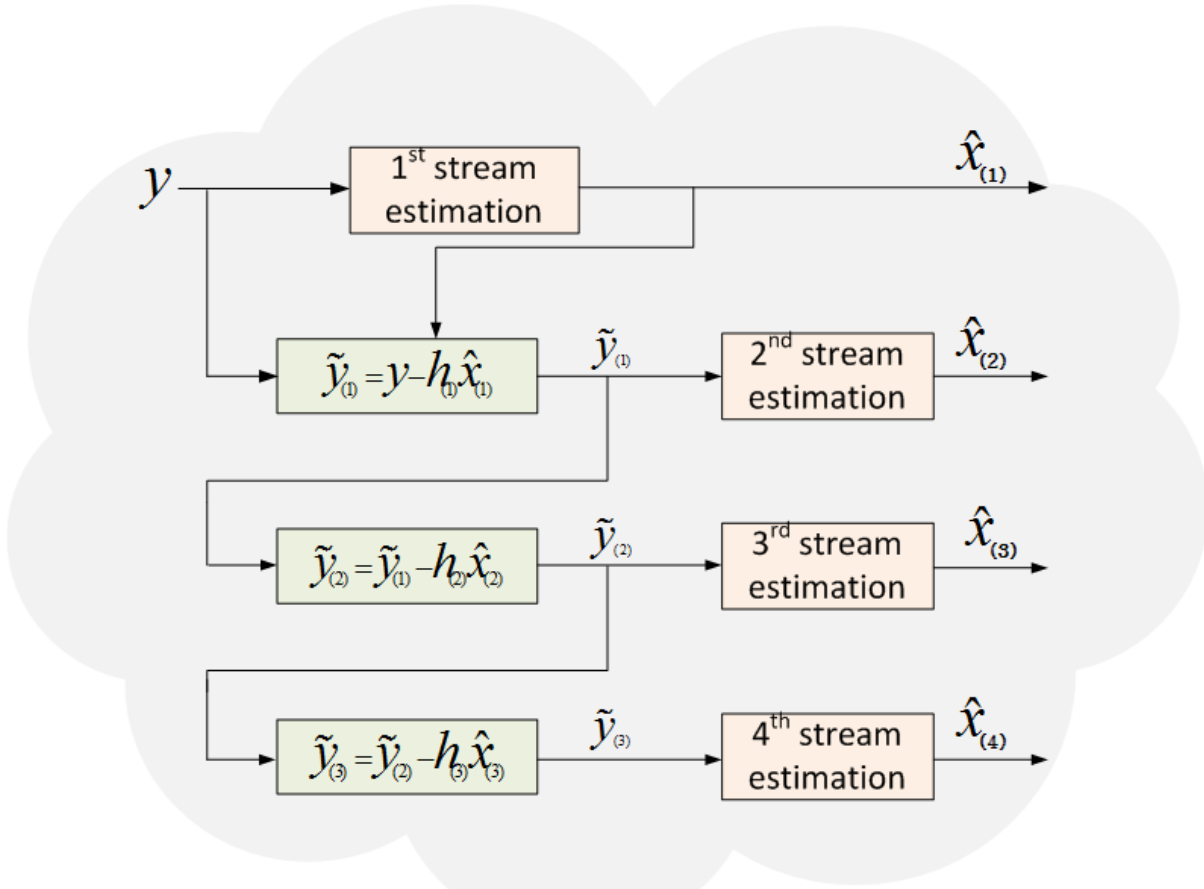

Figure 5.3: Illustration of OSIC signal detection for four spatial streams (i.e. $N_t = 4$)

streams, with the detected signal components successively canceled from the received signal at each stage. More specifically, the detected signal in each stage is subtracted from the received signal so that the remaining signal with the reduced interference can be used in the subsequent stage [4].

Figure 5.3 illustrates the OSIC signal detection process for four spatial streams. Let $x_{(i)}$ denote the symbol to be detected in the i th order, which may be different from the transmit signal at the i th antenna, since $x_{(i)}$ depends on the order of detection. Let $\hat{x}_{(i)}$ denote a sliced value of $x_{(i)}$. In the course of OSIC, either ZF method in Equation (5.6) or MMSE method in Equation (5.10) can be used for symbol estimation. The (1)st stream is estimated with the (1)st row vector of the MMSE weight matrix in Equation (5.10) After estimation and slicing to produce $\hat{x}_{(i)}$, the remaining signal in the first stage is formed by subtracting it from the received signal, that is,

$$\begin{aligned}
\tilde{\mathbf{y}} &= \mathbf{y} - \mathbf{h}_1 \hat{x}_1 \\
&= [\mathbf{h}_{(1)} \quad \dots \quad \mathbf{h}_{(N_t)}] \begin{bmatrix} x_{(1)} \\ \vdots \\ x_{(N_t)} \end{bmatrix} - \mathbf{h}_{(1)} \hat{x}_1 + \mathbf{n} \\
&= \mathbf{h}_{(1)} x_{(1)} + \dots + \mathbf{h}_{(N_t)} x_{(N_t)} - \mathbf{h}_{(1)} \hat{x}_1 + \mathbf{n} \\
&= \mathbf{h}_{(1)} (x_{(1)} - \hat{x}_1) + \mathbf{h}_{(2)} x_{(2)} + \dots + \mathbf{h}_{(N_t)} x_{(N_t)} + \mathbf{n}
\end{aligned} \tag{5.15}$$

If $x_{(1)} = \hat{x}_1$, then the interference is successfully canceled in the course of estimating $x_{(2)}$, however, if $x_{(1)} \neq \hat{x}_1$, then error propagation is incurred because the MMSE weight that has been designed under the condition of $x_{(1)} = \hat{x}_1$ is used for estimating $x_{(2)}$. Due to the error propagation caused by erroneous decision in the previous stages, the order of detection has significant influence on the overall performance of OSIC detection. In the sequel, we describe the different methods of detection ordering [4].

- **Method 1 (SINR-Based Ordering):** Signals with a higher post-detection signal-to-interference-plus-noise-ratio (SINR) are detected first. Consider the linear MMSE detection with the following post-detection SINR:

$$SINR_i = \frac{E_x |\mathbf{w}_{i,MMSE} \mathbf{h}_i|^2}{E_x \sum_{l \neq i} |\mathbf{w}_{i,MMSE} \mathbf{h}_l| + \sigma_n^2 \|\mathbf{w}_{i,MMSE}\|^2}, \quad i = 1, 2, \dots, N_t \tag{5.16}$$

where E_x is the energy of the transmitted signals, $\mathbf{w}_{i,MMSE}$ is the i th row of the MMSE weight matrix in Equation (5.10), and \mathbf{h}_i is the i th column vector of the channel matrix. Note that the mean-square error (MSE) is minimized and furthermore, the post-detection SINR is maximized by the MMSE detection. Once N_t SINR values are calculated by using the MMSE weight matrix of Equation (5.10), we choose the corresponding layer with the highest SINR. In the course of choosing the second-detected symbol, the interference due to the first detected symbol is canceled from the received signals. Suppose that $(1) = l$ (i.e., the l th symbol has been canceled first). Then, the channel matrix in Equation (5.10) is modified by deleting the channel gain vector corresponding to the l th symbol as follows:

$$\mathbf{H}^{(1)} = [\mathbf{h}_1 \ \mathbf{h}_2 \ \dots \ \mathbf{h}_{l-1} \ \mathbf{h}_{l+1} \ \dots \ \mathbf{h}_{N_t}] \tag{5.17}$$

Using Equation (5.17) in place of \mathbf{H} in Equation (5.10), the MMSE weight matrix is recalculated. Now, $(N_t - 1)$ SINR values, $\{SINR_i\}_{i=1, i \neq l}^{N_t}$, are calculated to choose the symbol with the highest SINR. The same process is repeated with the remaining signal after canceling the next symbol with the highest SINR. In MMSE-OSIC, the total number of SINR values to be calculated is $\sum_{j=1}^{N_t} j = N_t(N_t + 1)/2$.

- **Method 2 (SNR-Based Ordering):** When ZF weight in Equation (5.6) is used, the interference term in Equation (5.16) disappears, and the signal power $|\mathbf{w}_i \mathbf{h}_i|^2 = 1$, which reduces the post-detection SINR to

$$SNR_i = \frac{\mathbf{E}_x}{\sigma_n^2 \|\mathbf{w}_i\|^2}, \quad i = 1, 2, \dots, N_t \quad (5.18)$$

The same procedure of detection ordering as in Method 1 can be used, now using the SNR in Equation (5.18) instead of SINR in Equation (5.16). In this method, the number of SNR values to be calculated is also given by $\sum_{j=1}^{N_t} j = N_t(N_t + 1)/2$.

- **Method 3 (Column Norm-Based Ordering):** Note that both Methods 1 and 2 involve rather complex computation of a large number of SINR and SNR values, respectively, for detection ordering. In order to reduce the ordering complexity, we can use the norm of the column vectors in a channel matrix. Consider the following representation of the received signal:

$$\mathbf{y} = \mathbf{H}\mathbf{x} + \mathbf{n} = \mathbf{h}_1 x_1 + \mathbf{h}_2 x_2 + \dots + \mathbf{h}_{N_t} x_{N_t} + \mathbf{n} \quad (5.19)$$

from which we observe that the received signal strength of the i th transmitted signal is proportional to the norm of the i th column in the channel matrix. Therefore, we can detect the signal in the order of the norms $\|\mathbf{h}_i\|$. In this method, we need to compute N_t norms and then, order them only once. Detection is performed in the decreasing order of norms. Since ordering is required only once, complexity is significantly reduced as compared to the previous two methods.

In the next sections, results drawn from the simulated system model are presented. The tool used for building the simulation is **MATLAB**. The results are divided in the two main categories. The first is the results without Beam Gain Matrix and the second is with Beam Gain Matrix.

5.2 Without Beam Gain Matrix

In this section, several figures are presented referring to BER and Capacity. Comparisons have been made to various results using different parameters each time such as the number of antennas used for transmitting and/or receiving. Also, we can observe the values of each calculated BER and capacity given a specific signal to noise ratio (SNR in dB).

5.2.1 Bit-Error-Rate (BER)

BER curves for different scenarios are presented below. Firstly, we have BER for the described system model without beam gain matrix. Rayleigh fading is most applicable when there is no dominant propagation along a line of sight between the transmitter and receiver. If there is a dominant line of sight, Rician fading may be more applicable. In

the case “without beam gain matrix” Rayleigh channel is assumed on both hops, with QPSK modulation and amplification factor $\alpha = 2$.

A comparison has been made with the standard linear detection methods: ZF and MMSE techniques and the OSIC (including SIC-ZF, SIC-MMSE) signal detection. Then, we experiment with the number of antennas/relays and the value of the amplification factor presenting results for several MPSK scenarios.

BER

In figure 5.4 we compare the four (4) signal detection algorithms for a given number of antennas and relays more specific $N_t = N_r = M_r = 2$ (number of antennas) and $R=1$ (number of relays). We consider QPSK modulation and take into account amplification factor $\alpha = 2$. Observe the colored lines from the diagram’s legend. Specifically, the ZF is presented by the red line, the MMSE by the blue line, the SIC-ZF and the SIC-MMSE are presented by the purple and green line, respectively.

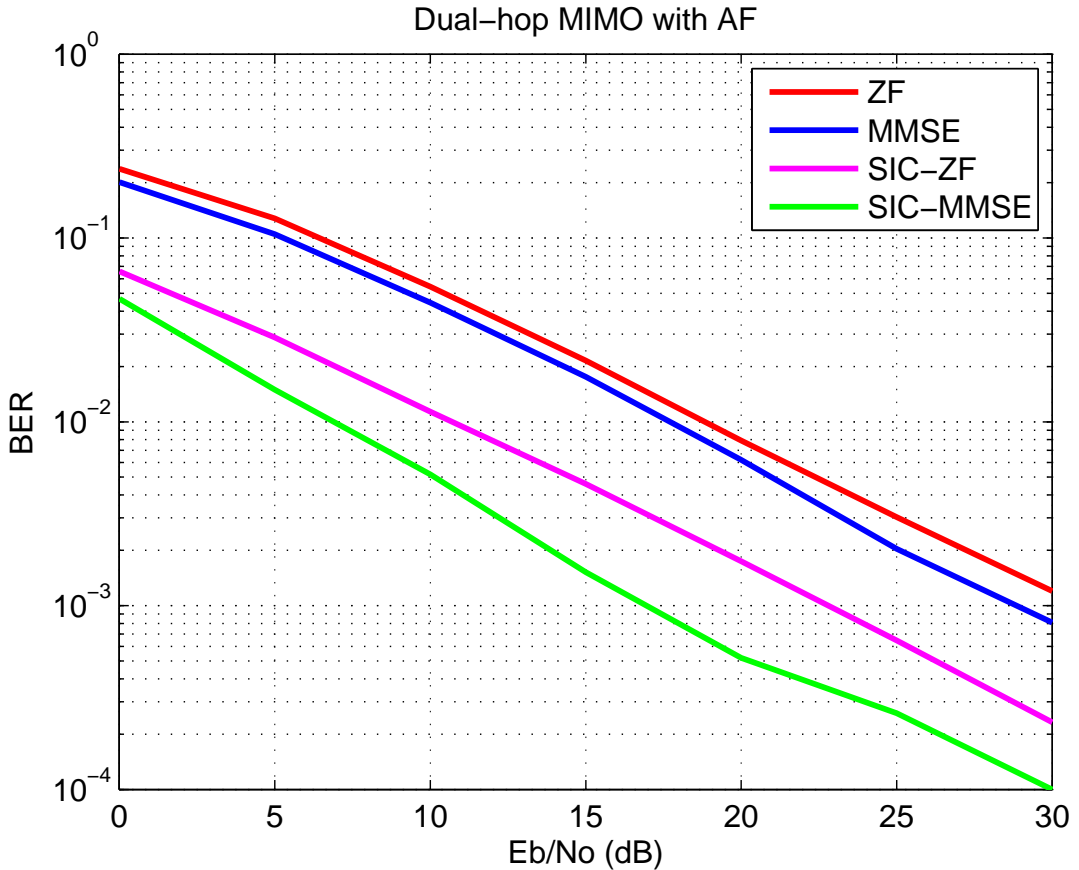

Figure 5.4: *BER for four signal detections*

The relationship between the four (4) signal detections based on BER is:

$$BER(SIC - MMSE) < BER(SIC - ZF) < BER(MMSE) < BER(ZF) \quad (5.20)$$

The receiver with the minimum value of BER (5.20) is considered the best. So, the relationship from the best to worst will be:

$$SIC - MMSE > SIC - ZF > MMSE > ZF \quad (5.21)$$

Amplification Factor

In addition, given a signal detection method we experiment with the value of the amplification factor. More specifically, we increase the constant variable in ZF signal detection for $N_t=N_r=M_r=2$ and $R=1$ similarly to the previous BER. We present the results for $a=2$, $a=4$, $a=6$ which are depicted with blue, red and green line, respectively.

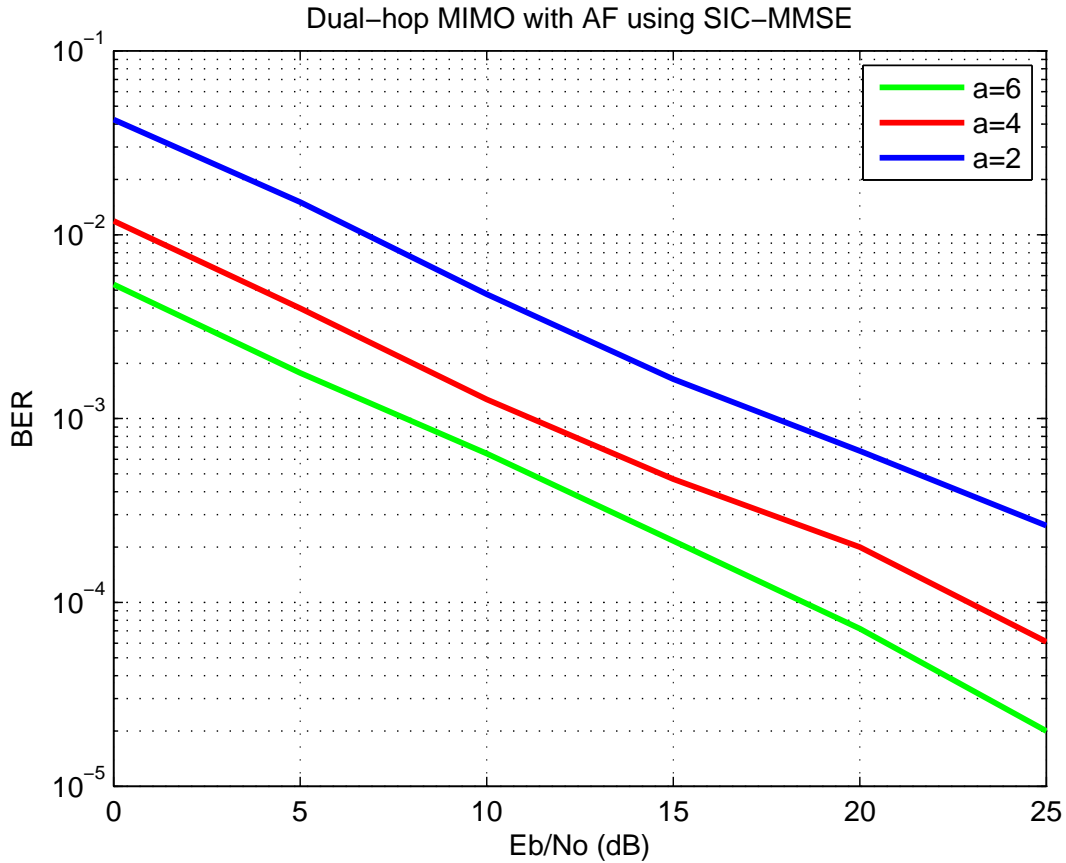

Figure 5.5: BER for different values of amplification factor

We observe that when we increase the amplification factor we get better result. So, between $a=2$, $a=4$ and $a=6$ we see that the best case occurs where the amplification factor is $a=6$.

$$a = 6 > a = 4 > a = 2 \quad (5.22)$$

MPSK

In this paragraph we compare the MPSK modulation for the ZF signal detection. Once again the same number of antennas and relays is used ($N_t = N_r = M_r = 2$ and $R = 1$). So, we can see in the figure 5.6 the results from BPSK, QPSK, 8-PSK and 16-PSK modulation with purple, black blue and red line respectively.

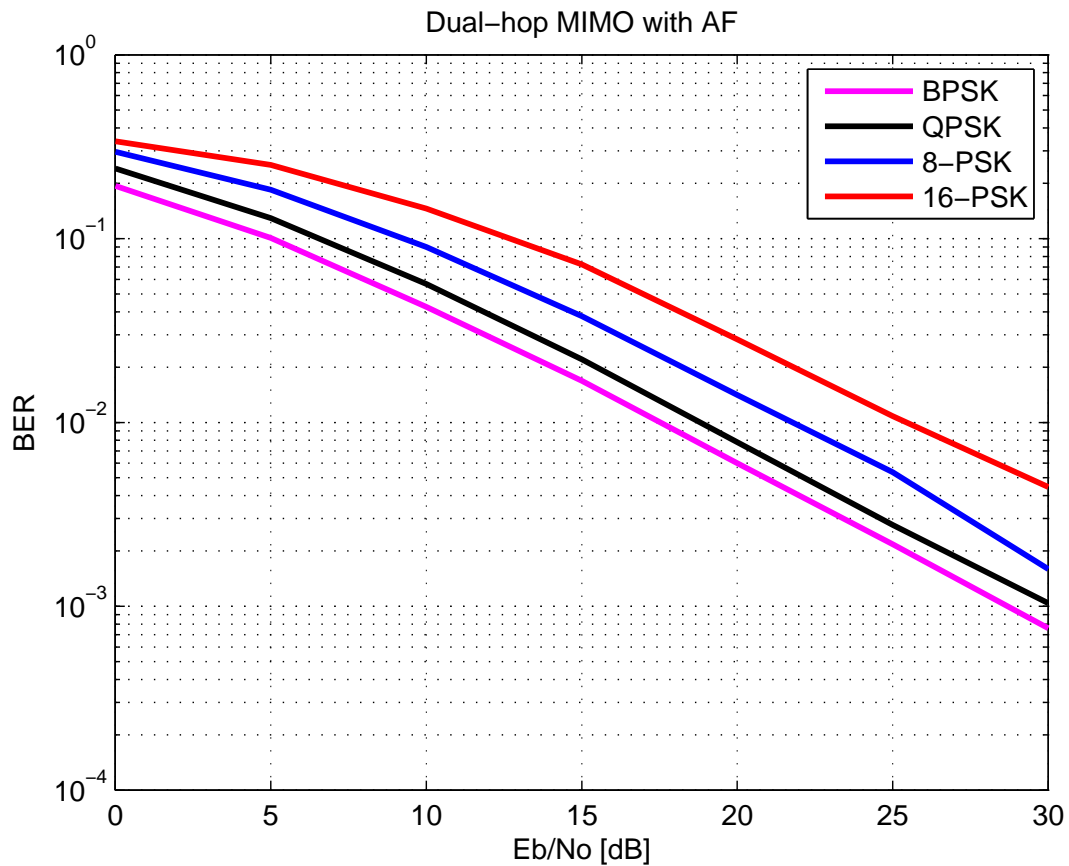

Figure 5.6: BER for different modulation values

We should remind that M denotes the symbols in the alphabet of each modulation. For example, the QPSK modulation, which has $M = 4$ symbols, can encode two bits per symbol, because $bits = \log_2(M)$. Likewise, the BPSK with $M = 2$ and $bits = 1/symbol$, the 8-PSK with $M = 8$ and $bits = 3/symbol$ and the 16-PSK with $M = 16$ and $bits = 4/symbol$.

Now, it is more obvious, that when we increase the M the value of BER is getting worse. So, the relationship among different kinds of mPSK modulation considering BER is:

$$BPSK > QPSK > 8 - PSK > 16 - PSK \quad (5.23)$$

Random number antennas and relays

In this part we take into account different values for the number of antennas and number of relays. The first case has $N_t = 2$, $N_r = 4$, $M_r = 3$ and $R = 1$, the second case has $N_t = N_r = M_r = R = 2$ and the third case $N_t = N_r = M_r = 2$ and $R = 1$. The number of relay's antenna is referred as $M = 2$ in the legend of figure 5.7 because in the beginning of this chapter was considered that $M_r = M_t = M$. All three cases are presented with purple, black and blue, respectively.

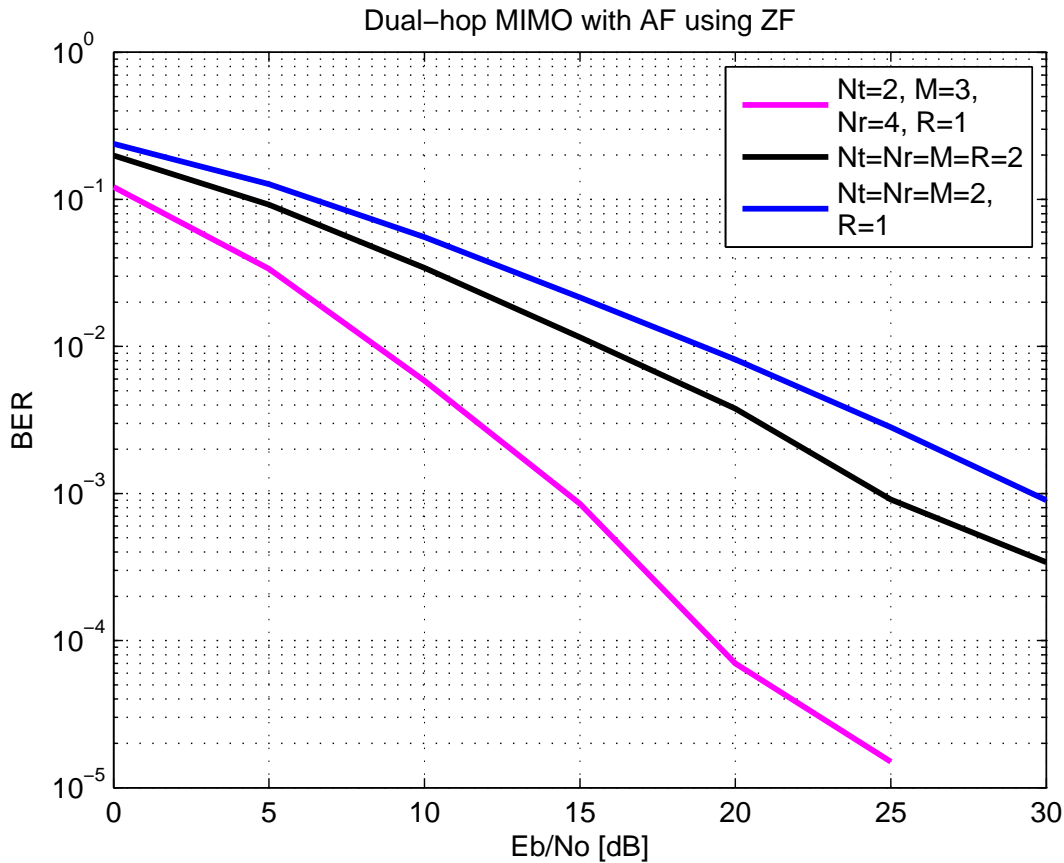

Figure 5.7: BER for different values of antennas and relays

Firstly, we observe the black and the blue line. The only difference here is the number of relays. For the black line we use two relays while in the blue line only one. From this comparison we can conclude that if we increase the number of relays the bit error rate (BER) is reduced. So, by increasing the number of relays we get better result. Let the three cases to be a, b and c respectively. Then the following relationship occurs:

$$b > c \quad (5.24)$$

For the first case, which is also the best of all three, we have increased the number of antennas to the relays and to the destination. The specific communication link includes only one relay node. Same as before the relationship which occurs from the figure 5.7, is:

$$a > b > c \quad (5.25)$$

5.2.2 Capacity

The ergodic capacity (in b/s/Hz) of the AF MIMO dual-hop system described above can be written:

$$C(\rho) = E\{\log_2 \det(\mathbf{I}_{(N_t)} + SNR * \mathbf{H}\mathbf{H}^H \mathbf{R}_n^{-1})\} \quad (5.26)$$

where \mathbf{R}_n is $N_r \times N_r$ matrix given by [16]:

$$\mathbf{R}_n = \mathbf{I}_{(N_r)} + \alpha \mathbf{H}_2 \mathbf{H}_2^H \quad (5.27)$$

with α is the constant value of amplification factor. We don't use the factor 1/2 like [9], [3], [44] because the factor 1/2 accounts for the fact that information is conveyed to the destination terminal when we have half duplex. In our system model we considered an mPSK, amplify-and-forward (AF), multirelay and multiusers MIMO system with full-duplex relays.

Capacity

Figure 5.8 shows the Capacity for two additional techniques, the MMSE and the ZF receivers. The capacity of a channel in a MIMO system with linear detector (LD) can be written as:

$$C_{LD} = \sum_{i=1}^k \log_2(1 + SINR_k) \quad (5.28)$$

where $SINR_k$ for each receiver is different.

The signal-to-interference-plus-noise ratio (SINR) for the minimum mean-square error (MMSE) receiver in multiple-input multiple-output (MIMO) wireless communications on the k th spatial stream can be expressed as [29], [20], [33], [27], [25], [37], [44]:

$$SINR_k^{MMSE} = \frac{1}{[(\mathbf{I}_{N_t} + SNR * \mathbf{H}^H (\mathbf{R}_n)^{-1} \mathbf{H})^{-1}]_{kk}} - 1 \quad (5.29)$$

where \mathbf{I} is a $N_t \times N_t$ identity matrix and \mathbf{H}^H is the Hermitian transpose of \mathbf{H} .

The signal-to-interference-plus-noise ratio (SINR) for the zero-forcing ZF receiver, denoted by $SINR_k^{ZF}$, which, conditional on \mathbf{H} , can be expressed as [37], [25], [43]:

$$SINR_k^{ZF} = \frac{SNR}{[(\mathbf{H}^H (\mathbf{R}_n)^{-1} \mathbf{H})^{-1}]_{kk}} \quad (5.30)$$

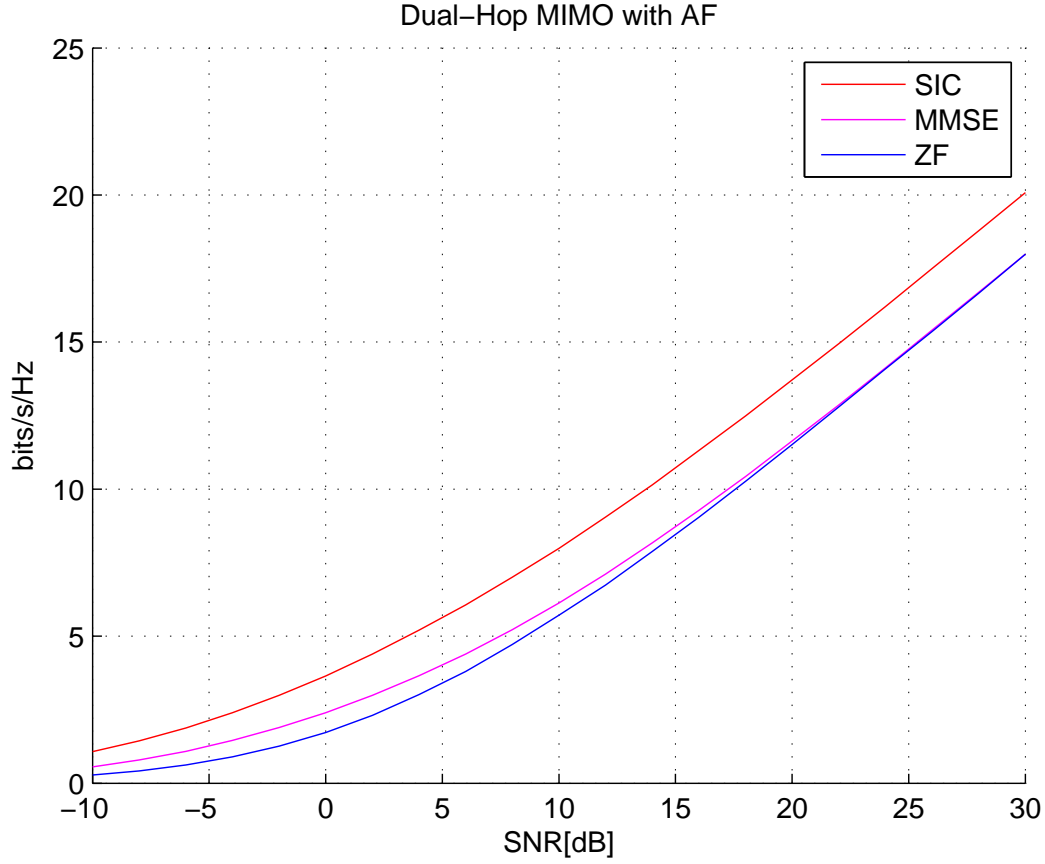

Figure 5.8: *Ergodic Capacity for ZF, MMSE and SIC*

In figure 5.8 is depicted the capacity of the three presented methods ZF, MMSE and SIC with blue, purple and red line respectively. We observe that the ZF and MMSE for high SNR coincide. On the other hand, for low SNR the MMSE is better than ZF.

Again, the relationship from the best to worse is:

- **For high SNR where $ZF = MMSE$ is:**

$$SIC > (ZF = MMSE) \quad (5.31)$$

- **For low SNR is:**

$$SIC > MMSE > ZF \quad (5.32)$$

Comparisons of capacity results with single relay antenna

Here we try to understand more details.

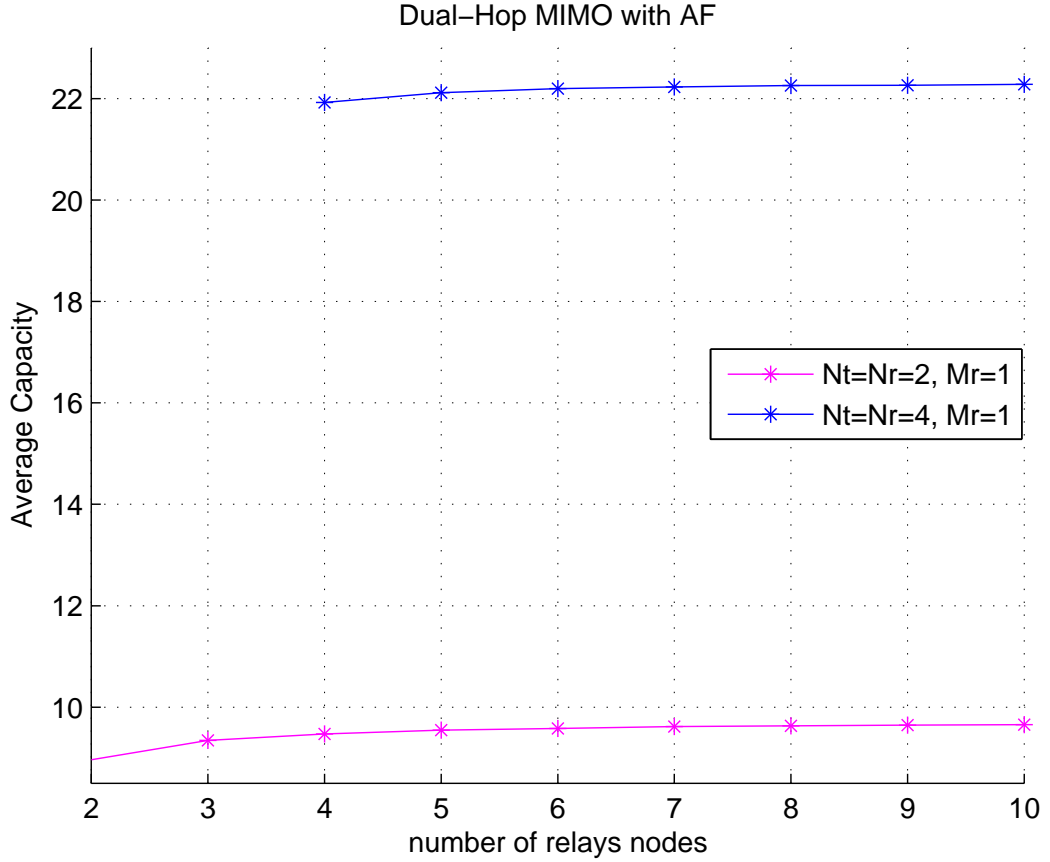

Figure 5.9: Comparisons capacity with single relay antenna

From figure 5.9 we observe that the capacity increases when increasing the number of relay nodes, using multi-antennas to the source and destination node and single antenna in each relay node. More specifically, we compare the average capacity for $N_t = N_r = 2$ and $N_t = N_r = 4$ with purple and blue line, respectively.

It is understood that when we increase the number of antennas to the source and destination node, the capacity is also increased. Having these two cases and let A be the first case with $N_t = N_r = 2$ and B the second case with $N_t = N_r = 4$. The relationship which shows the best is:

$$B > A \quad (5.33)$$

Comparisons of capacity results with multiple relay antennas

In this paragraph we use multiple relay antennas in order to retrieve results on capacity. More specifically, we use $N_t = N_r = 2$ and $M_r = 1, M_r = 2$ and $M_r = 4$ with red, purple and blue line respectively.

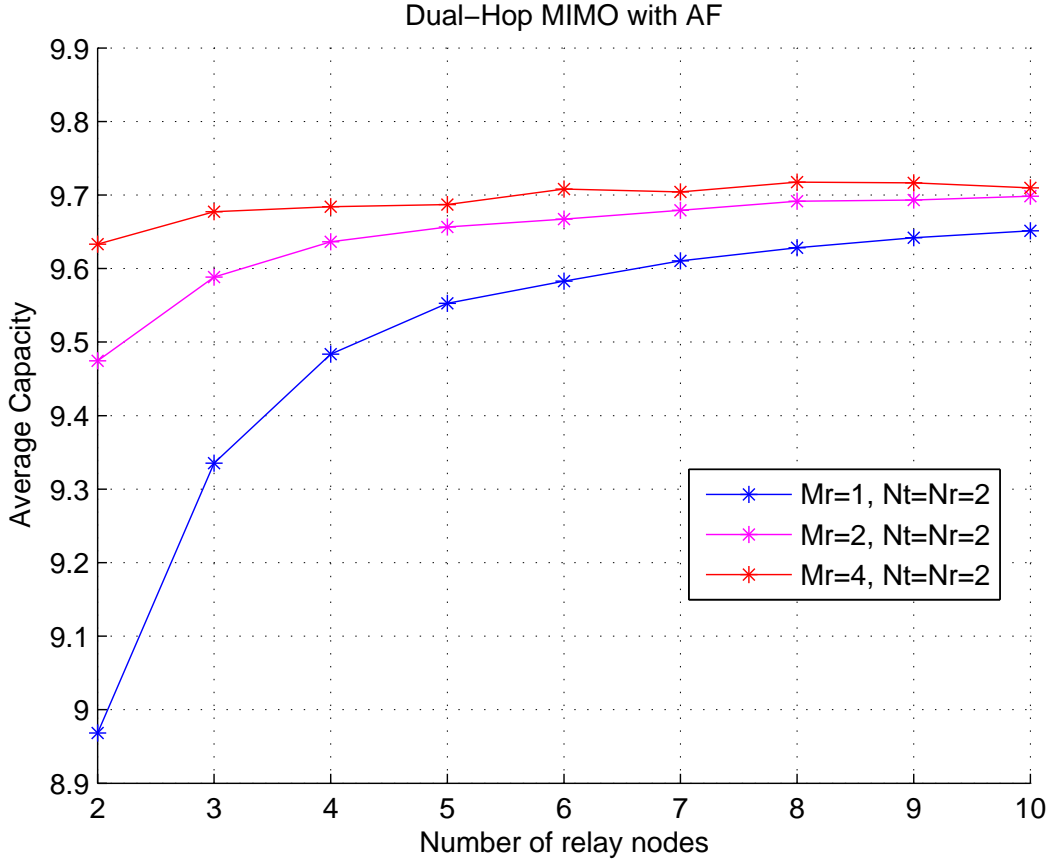

Figure 5.10: Comparisons capacity with multiple relay antennas

The results from figure 5.10 show that the difference between the values of each capacity reduces as we increase the number of antenna relays for each relay node (1-10). So, based on this fact, capacity for different number of relay nodes will have the relationship from the higher difference to lower. Let $M_r = 1$, $M_r = 2$ and $M_r = 4$ to be a , b and c respectively.

$$a > b > c \quad (5.34)$$

5.3 With Beam Gain Matrix

One of the main reasons why satellite communications are challenging and different from terrestrial communications is due to the satellite channel characteristics, which need to be properly modeled. The satellite channel above 10GHz operating under line-of-sight (LOS) is subjected to various atmospheric fading effects originating in the troposphere, which severely degrade system performance and availability. Among them, rain attenuation is the dominant factor and will be taken into account in our modeling. In the following we will describe in detail the satellite channel effects including free space loss, rain fading and the beam gain pattern.

- **Free Space Loss (FSL):** Due to the earth curvature and the wide satellite coverage, the free space loss in each multibeam will not be identical. In order to model this effect, the FSL coefficient of the k th multibeam can be written as

$$b_{max}(k) = \left(\frac{\lambda}{4\pi}\right)^2 \frac{1}{(d_0)^2 + d(k)^2} \quad (5.35)$$

where λ is the wavelength and $d(k)$ denotes the distance of the k th beam center from the center of the central beam and $d_0 \simeq 35789 \text{ km}$

- **Rain Fading:** Rain fading is the dominant factor and will be taken into account in the course of our analysis. To model the rain attenuation effect we use the latest empirical model proposed in the ITU-R2 Recommendation P.618. The distribution of the power gain ξ in dB, $\xi_{dB} = 20 \log_{10}(\xi)$, is commonly modeled as a lognormal random variable, i.e., $\ln(\xi_{dB}) \sim \mathcal{N}(\mu, \sigma)$, where μ and σ depend on the location of the receiver, the frequency of operation, polarization and the elevation angle toward the satellite. The probability density function of a lognormal variable ξ reads as

$$p(\xi) = \frac{1}{\xi\sqrt{2\pi\sigma^2}} \exp\left(-\frac{(\ln \xi - \mu)^2}{2\sigma^2}\right), \quad \xi \geq 0 \quad (5.36)$$

Variables μ (dB) and σ (dB) are the mean and standard deviation of the variables natural logarithm respectively.

The corresponding $K \times 1$ (where K is the adjacent beams in a cluster, on ground formed by K antenna feeds (single-feed per beam) on board the satellite and full frequency reuse among beams is assumed) rain fading coefficients from all antenna feeds towards a single terminal antenna are given in the following vector:

$$\tilde{\mathbf{h}} = \xi^{\frac{1}{2}} e^{-j\phi} \mathbf{1}_N \quad (5.37)$$

where ϕ denotes a uniformly distributed phase. The phases from all antenna feeds are hard to differentiate and assumed to be identical. This is because we consider a LOS environment and the satellite antenna feed spacing is not large enough compared with the communication distance.

Since rain attenuation is a slow fading process that exhibits spatial correlation over tens of kms, we assume that users undergo the same fading when located within the same beam, but independent fading among beams. In other words, we assume that each beam comprises a correlated area

- **Beam Gain:** The link gain matrix defines the average signal to interference-plus-noise ratios (SINR) of each user and it mainly depends on the satellite antenna beam pattern and the user position. Define one user's position based on the angle θ between the beam center and the receiver location with respect to the satellite and θ_{3dB} is its 3-dB angle. Then the beam gain is approximated by:

$$b(\theta, k) = \left(\frac{J_1(u)}{2u} + 36 \frac{J_3(u)}{u^3} \right)^2 \quad (5.38)$$

where $u = 2.07123 \sin \theta / \sin \theta_{3dB}$ and J_1, J_3 are the first kind Bessel functions, of order one and three respectively. The j -th user corresponds to an off-axis angle θ with respect to the boresight of the i -th beam where $\theta_i = 0^\circ$. The coefficient $b_{max} = \left(\frac{\lambda}{4\pi} \right)^2 \frac{1}{(d_0)^2}$, where λ is the wavelength and $d_0 \simeq 35789 \text{ km}$, is the satellite altitude. [45]

5.3.1 Beams

In this subsection we can see in a multi-beam system the frequency reuse and how the users can be located in each beam. For the creation a multi-beam we should define some parameter details. More specifically:

- Acceptable beam numbers: 7, 19, 37, 61, 91, 127 ...
- Assume one user per beam
- Radius of the considered area in km

Frequency reuse

Figure 5.11 presents a conventional 4-color frequency reuse scheme. We have depicted a simple example, considering $\text{radius_area}=100\text{km}$ and with a typical reuse factor $N = 4$ with $i = 2$ and $j = 0$, where $N = i^2 + ij + j^2$.

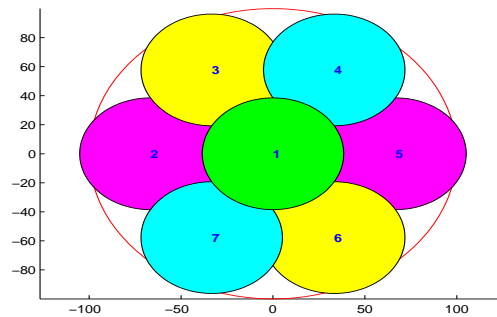
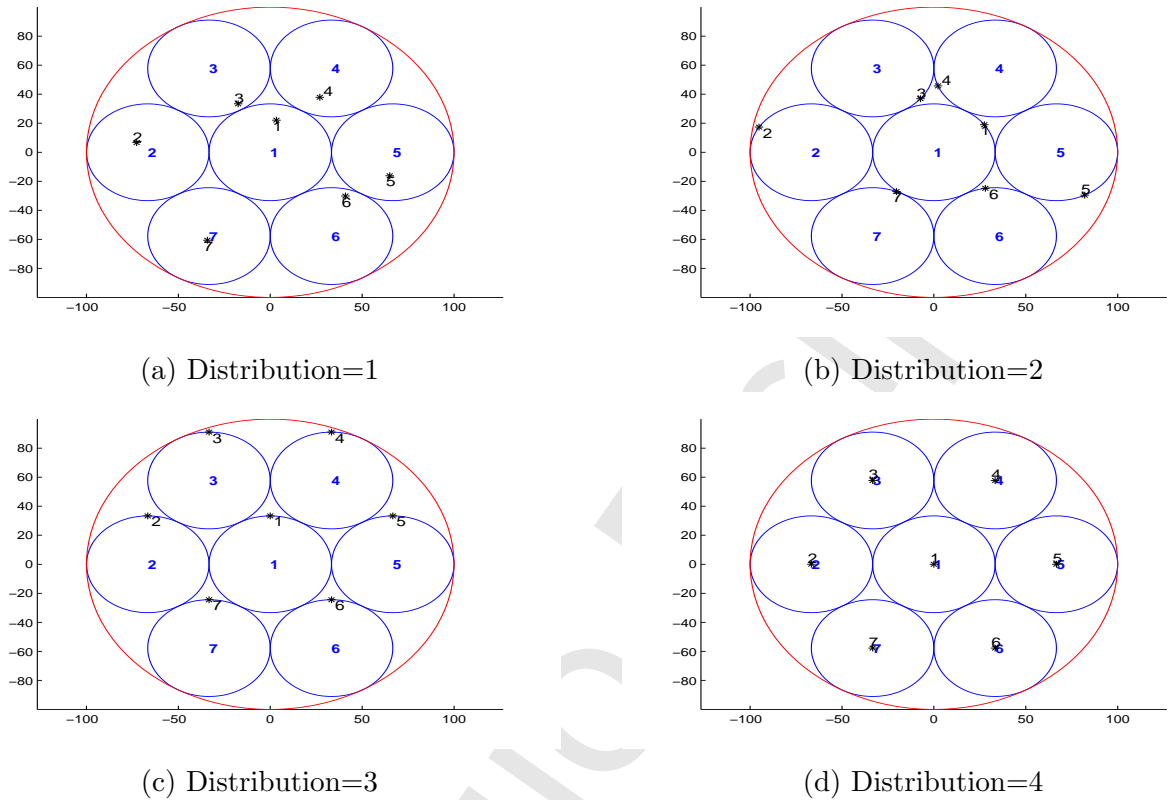

Figure 5.11: *Frequency reuse*

User Distributions

This subsection is referred in the distributions of users in each beam. Every distribution's value corresponds in different positions of beams.

Figure 5.12: *Distributions*

More specifically, we have the following cases as we can also see in figure 5.12, :

- **Distribution=1:** The user is a random point from the center to radius. This is calculated by

```

if distribution == 1
    distance = rand(1, 1) * beam_radius;
    angle = rand(1, 1) * 2 * pi;

```

- **Distribution=2:** The user is a random point over the cell. The difference with the distribution=1 is that here we have distance=beam radius. This is calculated by

```

else if distribution == 2
    distance = beam_radius;
    angle = rand(1, 1) * 2 * pi;

```

- **Distribution=3:** The user is in a specific point ($angle = 2\pi$) over the cell. The difference with the distribution=2 is that here we don't use random angle. This is calculated by

```

else if distribution == 3

```

```

distance = beam_radius;
angle = 2 * pi;

```

- **Distribution=4:** The user is in the center of cell. The difference with distribution=3 is that here the $distance \simeq 0.0001$. We cannot use $distance = 0$ because we will not get any results. So, we used a very close to zero value. This is calculated by

```

else if distribution == 3
distance = 0.0001;
angle = 2 * pi;
end

```

5.3.2 BER for Multibeam MIMO system

In this subsection BER results are presented for multi-beam MIMO system. From the source to the relay nodes we consider Rayleigh channel and from the relay to the destination node Rician channel because the relay nodes always have a direct link with the satellite. The Rician fading is modeled as:

$$\mathbf{H}_{ric} = \sqrt{\frac{K}{K+1}} \bar{\mathbf{H}} + \sqrt{\frac{1}{K+1}} \tilde{\mathbf{H}} \quad (5.39)$$

where K is the Rician factor, $\bar{\mathbf{H}}$ is a deterministic unit rank matrix modeling the LoS signal component and $\tilde{\mathbf{H}}$ is a complex random matrix representing the scattered components.

So, here we use as channel from relay to destination:

$$\mathbf{H}_{2rician} = \mathbf{H}_2 \odot \mathbf{B} \quad (5.40)$$

where \mathbf{B} is the Beam gain Matrix and \odot is element wise multiplication.

We take into account that we have QPSK modulation and amplification factor $\alpha = 2$. So, firstly, we observe the results of BER for the different user positions and continuing the results of BER for the four receivers which we also used in the section “Without Beam Gain Matrix”.

BER

In figure 5.13 we compare the four (4) signal detection algorithms, alike figure 5.4, for the following parameters used $N_r=N_t=M_r=2$ and $R=1$. We can see the colored lines from the legend. Specifically, the ZF is presented by the red line, the MMSE by the blue line, the SIC-ZF and the SIC-MMSE are presented by the purple and green line, respectively.

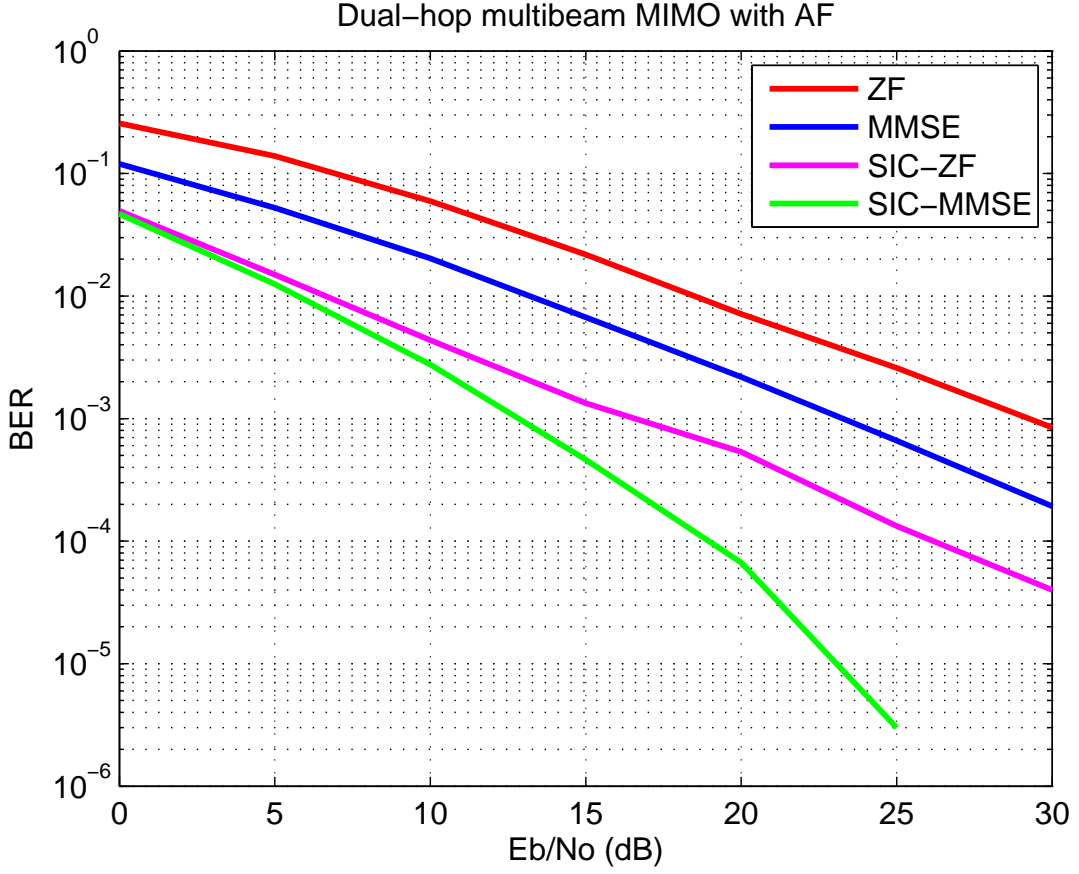

Figure 5.13: *BER for Multibeam MIMO system using the four signal detections*

In figure 5.4 we can observe that the relationship between BER and the four receivers is the same with (5.20) and (5.21). The difference is that with the beam gain matrix we have better results from the BER without beam gain matrix.

$$BER(SIC - MMSE) < BER(SIC - ZF) < BER(MMSE) < BER(ZF) \quad (5.41)$$

The receiver with the minimum value of BER (5.41) is the best. So, the relationship from the best to worst is:

$$SIC - MMSE > SIC - ZF > MMSE > ZF \quad (5.42)$$

User Positions

Here we can see for every distribution how BER is behaving. We expect that the best case scenario is when the user is in the beamcenter (Distribution=4). We use ZF signal detection with $N_r=N_t=M_r=2$ and $R=1$. We also presented the cases user_position=1, user_position=2, user_position=3 and user_position=4 with blue, red, green and black line respectively.

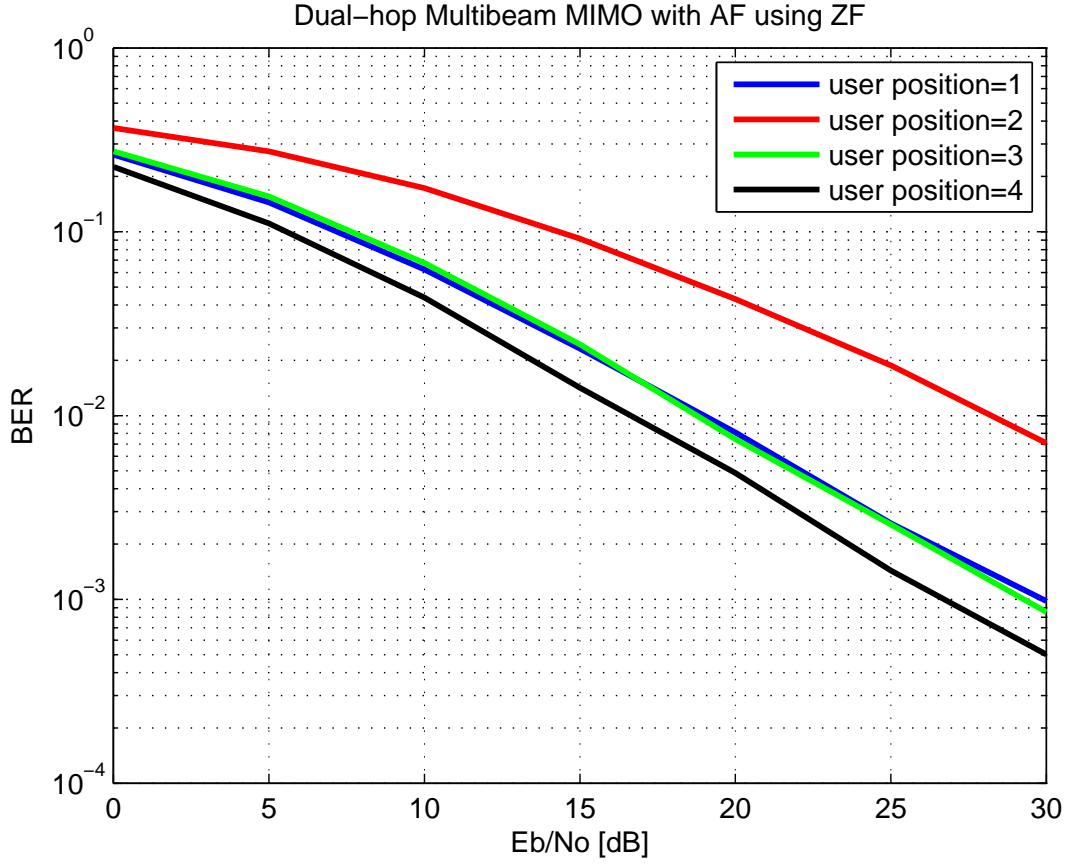
Figure 5.14: *BER for each User Position*

The relationship of BER between user positions is:

$$BER(distr = 4) < BER(distr = 1) < BER(distr = 3) < BER(distr = 2) \quad (5.43)$$

The user position with the minimum value of BER (5.43) is the best. So, the relationship from the best to worst is:

$$distr = 4 > distr = 1 > distr = 3 > distr = 2 \quad (5.44)$$

5.3.3 Gain

In order to understand the gain achieved with beam gain matrix we will compare the BER for ZF signal detection in the best user position (user_postion=4), with Rician channel and Beam Gain Matrix with Rician channel.

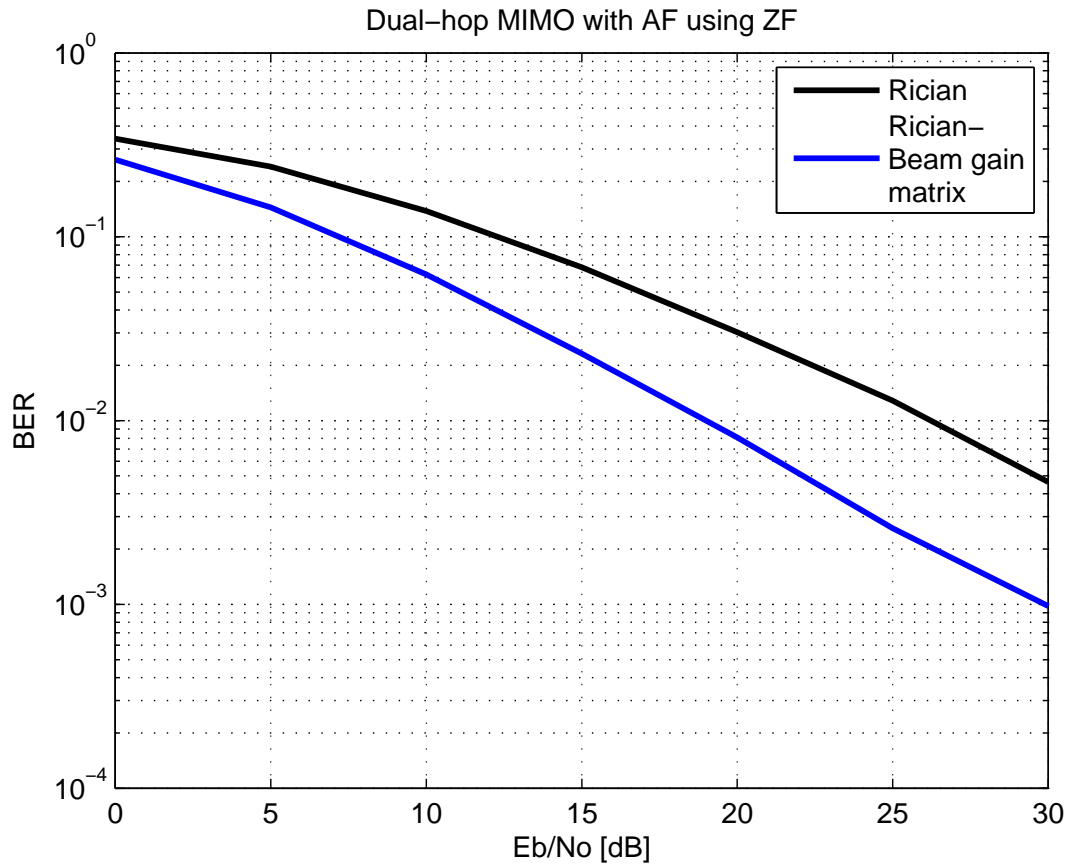

Figure 5.15: *Rician vs Rician with beam gain matrix*

We observe that the gain is dramatically increased. We also present the Rician without Beam Gain Matrix and the Rician with Beam Gain Matrix with black and blue line respectively. Based on BER we have the next relationship:

$$BER(Rician_Beam_gain_matrix) < BER(Rician) \quad (5.45)$$

The case with the minimum value of BER (5.45) is the best. So, the relationship from the best to worst is:

$$Rician_Beam_gain_matrix > Rician \quad (5.46)$$

Πανεπιστήμιο Πειραιώς

Chapter 6

Conclusion

6.1 Conclusions

This dissertation has presented a dual-hop MIMO satellite communication system with the Amplify and Forward (AF) technique. Based on the results, we can see, firstly, that when we increase the number of relay nodes, for specific number of transmit, receive and relay antennas, the capacity results do not undergo any important changes. A worth-mentioned difference arises when we increase the number of transmit and receive antennas. Moreover, in the case where we increase the number of relay antennas, there is no major change in the capacity. Continuing, four signal detection techniques (ZF, MMSE, SIC-ZF, SIC-MMSE) are used in two different cases. The case “without Beam Gain Matrix” and the case “with Beam Gain Matrix”. From both of these cases it is observed that the SIC-MMSE performs the best of the other techniques, while the ZF performs the worst. Also, in the case “with Beam Gain Matrix” we have four user distributions (user positions), where the best user position is when the user is in the center of each beam. The gain which we have when we use the beam gain matrix with Rician channel is nearly 5dB. Finally, we clarify that as we increase the amplification factor the channel performs better, whereas increasing the M factor for modulation purposes the channel will perform worse. So, the BPSK is the best of all the other MPSK modulations in terms of BER performance.

To sum up, the best case scenario is having a system with BPSK modulation, a beam gain matrix and using the SIC-MMSE signal detection technique. Also, taking into account that the best position for the user is to be in the center of the beam (user position=4) we achieve the most desirable results.

6.2 Future work

As a proposed future work we could have a multi-hop multi-beam MIMO satellite system with multi-users which means more source nodes and also more destination nodes. More specifically, let the source nodes be the satellites, the destination nodes be the mobile terminals and the relay nodes be the mobile relays. For example, let's see how many users we could have had in the proposed system and how many antennas there would have been.

Nodes \ Numbers	# Numbers	# Antennas
Satellites	1-3	1-4/per satellite
Relays	1-10 /per beam	1-4/per relay
Mobile Terminals	1-10 /per beam	1-4/per terminal

The number of beams would be 1, 3, 7, 19, 37, 61, 91, 127 The proposed scheme could be scrupulously searched and analyzed to the forward link (Down Link (DL)) and to the return link (Up Link (UL)). Apart from Amplify and Forward (AF), which has already been used, Decode and Forward (DF) is the next step in the right direction. Also, the direct link from the source to the destination could be added so as to have two received signals to the destination.

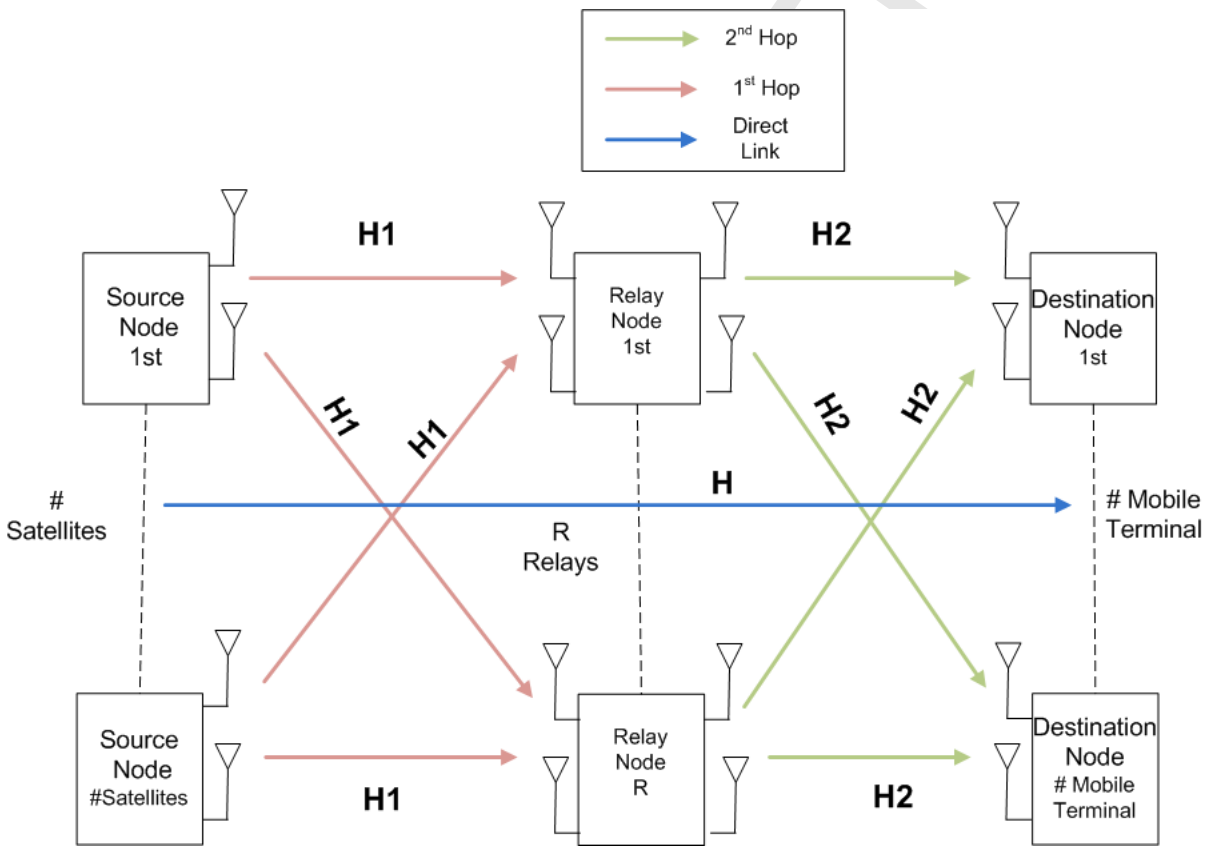

Figure 6.1: *Future System Model*

In figure 6.1 is presented how could be the system model with more users (source and destination) and with direct link.

Chapter 7

References

- [1] Siavash M. Alamouti. *A simple transmit diversity technique for wireless communications*. volume 16, pages 1451–1458. Selected Areas in Communications, IEEE Journal on, October 1998.
- [2] H. Khaleghi Bizaki. *MIMO Systems, Theory and Applications*. InTech, Janeza Trdine 9, 51000 Rijeka, Croatia, first edition, March 2011.
- [3] Helmut Bölcskei, Rohit U. Nabar, Özgür Oyman, and Arogyaswami J. Paulraj. *Capacity scaling laws in MIMO relay networks*. volume 5, pages 1433–1444. Wireless Communications, IEEE Transactions, June 2006.
- [4] Yong Soo Cho, Jaekwon Kim, Won Young Yang, and Chung G. Kang. *MIMO-OFDM Wireless Communications with Matlab*. Wiley, 2010.
- [5] Dimitrios Christopoulos, Symeon Chatzinotas, Gan Zheng, Joel Grotz, and Björn Ottersten. *Linear and nonlinear techniques for multibeam joint processing in satellite communications*. EURASIP Journal on Wireless Communications and Networking 2012, 4 May 2012.
- [6] PhD Candidate Dimitrios A. Christopoulos. *Capacity Limits Of MIMO systems*. SnT, University of Luxembourg.
- [7] Shuguang Cui, Andrea J. Goldsmith, and Ahmad Bahai. *Energy-efficiency of MIMO and cooperative MIMO techniques in sensor networks*. pages 1089–1098. Selected Areas in Communications, IEEE Journal, 6 August 2004.
- [8] Mischa Dohler and Yonghui Li. *Cooperative Communications Hardware, Channel & PHY*. Wiley, United Kingdom, UK, first edition, 2010.
- [9] Abdulla Firag, Peter J. Smith, and Matthew R. McKay. *Capacity Analysis for MIMO Two-Hop Amplify-and-Forward Relaying Systems with the Source to Destination Link*. pages 1–6. Communications, 2009. ICC '09. IEEE International Conference, June 2009.
- [10] Gerard J. Foschini. *Layered space-time architecture for wireless communication in a fading environment when using multi-element antennas*. pages 41–59. Bell Labs Technical Journal, summer 2006.

- [11] Andrea Goldsmith. *Wireless Communications*. Cambridge University Press, Stanford University, 2005.
- [12] Ekram Hossain, Dong In Kim, and Vijay K. Bhargava. *Cooperative Cellular Wireless Networks*. Cambridge University Press, first edition, 2011.
- [13] Arif Iqbal and Kazi M. Ahmed. *A Hybrid Satellite-Terrestrial Cooperative Network over Non Identically Distributed Fading Channels*. Journal Of Communications, October 2011.
- [14] W. Jakes. *Microwave Mobile Communications*. Wiley, New York, NY, 1974.
- [15] Mark R. Bell Jiann-Ching Guey, Michael P. Fitz and Wen-Yi Kuo. Signal design for transmitter diversity wireless communication systems over rayleigh fading channels. In *Vehicular Technology Conference, 1996. 'Mobile Technology for the Human Race'.*, *IEEE 46th*, volume 1, pages 136–140, 28 April-1 May 1996.
- [16] Shi Jin, Matthew R. McKay, Caijun Zhong, and Kai-Kit Wong. *Ergodic Capacity Analysis of Amplify-and-Forward MIMO Dual-Hop Systems*. volume 56, pages 2204–2224. IEEE Transactions on Information Theory, July 6-11 2008.
- [17] Robert W. Heath Jr. and Arogyaswami Paulraj. Transmit diversity using decision-directed antenna hopping. In *Communication Theory Mini-Conference, 1999*, pages 141–145, June 1999.
- [18] Prof. Markku Juntti, Prof. Tadashi Matsumoto, Docent Ian Oppermann, and Docent Juha Ylitalo. *Communications in wireless MIMO channels: Channel models, baseband algorithms, and system design*. University of Oulu, University of Oulu/ Elektrobit, University of Oulu/ Southern Poro Comm. & Nokia/University of Oulu respectively.
- [19] Prof. Athanasios Kanatas. *Performance Evaluation of Telecommunication Systems, Lecture 9 "Spatial Multiplexing"*. University of Piraeus.
- [20] Namshik Kim, Yusung Lee, and Hyuncheol Park. *Performance Analysis of MIMO System with Linear MMSE Receiver*. volume 7, pages 4474–4478. Wireless Communications, IEEE Transactions on, November 2008.
- [21] Sooyoung Kim, Hee Kim, Kunseok Kang, and Do Ahn. *Performance Enhancement in Future Mobile Satellite Broadcasting Services*. volume 46, pages 118–124. IEEE Communications Magazine, July 2008.
- [22] Michael O. Kolawole. *Satellite Communication Engineering*. CRC Press by Marcel Dekker, New York, Basel, first edition, 2002.
- [23] Sastri Kota, Giovanni Giambene, and Sooyoung Kim. *Satellite component of NGN: Integrated and Hybrid Networks*. International Journal of Satellite Communications and Networking, 13 May 2010.

- [24] Wen-Yi Kuo and M.P. Fitz. *Design and analysis of transmitter diversity using intentional frequency offset for wireless communications*. volume 46, pages 871 – 881. Vehicular Technology, IEEE Transactions on, November 1997.
- [25] Ping Li, Debashis Paul, Ravi Narasimhan, and John Cioffi. *On the distribution of SINR for the MMSE MIMO receiver and performance analysis*. volume 52, pages 271–286. Information Theory, IEEE Transactions on, January 2006.
- [26] K. J. Ray Liu, Ahmed K. Sadek, Weifeng Su, and Andres Kwasinski. *Cooperative Communications and Networking*. Cambridge University Press, Cambridge, New York, Melbourne, Madrid, Cape Town, Singapore, São Paulo, first edition, 2009.
- [27] Jing Ma, Ying Jun (Angela) Zhang, Xin Su, and Yan Yao. *On capacity of wireless ad hoc networks with MIMO MMSE receivers*. volume 7, pages 5493–5503. Wireless Communications, IEEE Transactions on, December 2008.
- [28] Thomas L. Marzetta and Bertrand M. Hochwald. *Capacity of a mobile multiple-antenna communication link in Rayleigh flat fading*,. pages 139–157. IEEE Transactions on Information Theory, January 1999.
- [29] Aris L. Moustakas. *SINR distribution of MIMO MMSE receiver*. pages 938–942. Information Theory Proceedings (ISIT), 2011 IEEE International Symposium on, July 31 2011-Aug. 5 2011.
- [30] Hakan Olofsson, Magnus Almgren, and Mikael Hook. Transmitter diversity with antenna hopping for wireless communication systems. In *Vehicular Technology Conference, 1997, IEEE 47th*, volume 3, pages 1743–1747, May 1997.
- [31] Arogyaswami Paulraj, Rohit Nabar, and Dhananjay Gore. *Introduction to Space-Time Wireless Communications*. Cambridge University Press, The Pitt Building, Trumpington Street, Cambridge, United Kingdom, first edition, 2003.
- [32] Arogyaswami J. Paulraj and Thomas Kailath. *Increasing capacity in wireless broadcast systems using distributed transmission/directional reception (DTDR)*. US Patent, 9 June 1994.
- [33] H. Vincent Poor and Sergio Verdú. *Probability of error in MMSE multiuser detection*. volume 43, pages 858–871. Information Theory, IEEE Transactions on, May 1997.
- [34] Gregory G. Raleigh and John M. Cioffi. *Spatio-temporal coding for wireless communication*. pages 357–366. IEEE Transactions on Communications, March 1998.
- [35] N. Seshadri and Jack H. Winters. Two signaling schemes for improving the error performance of frequency-division-duplex (fdd) transmission systems using transmitter antenna diversity. In *Vehicular Technology Conference, 1993., 43rd IEEE*, pages 508–511, May 1993.
- [36] Dr. Jacob Sharony. *Introduction to Wireless MIMO—Theory and Applications*. Center of Excellence in Wireless & IT (Information Technology) Stony Brook University. IEEE LI, 15 November 2006.

- [37] Samarendra Nath Sur and Rabindranath Bera. *Capacity Analysis of the VBLAST MIMO System in Fading Condition with M-QAM Modulation*. volume 25, pages 38–41. International Journal of Computer Applications, July 2011.
- [38] Xiaofeng Tao, Xiaodong Xu, and Qimei Cui. *An Overview of Cooperative Communications*. volume 50, pages 65–71. IEEE Communications Magazine, IEEE Communications Society, June 2012.
- [39] I. Emre Telatar. *Capacity of multi-antenna Gaussian channels*. pages 585–595. European Transaction Telecommunications, November/ December 1999.
- [40] Cheng-Xiang Wang, Xuemin Hong, Xiaohu Ge, Xiang Cheng, Gong Zhang, and John Thompson. *Cooperative MIMO channel models: A survey*. pages 80–87. IEEE Communications Magazine, February 2010.
- [41] Jack H. Winters. *On the capacity of radio communication systems with diversity in a Rayleigh fading environment*. pages 872–878. IEEE Journal on Selected Areas in Communications, June 1987.
- [42] A. Wittneben. *Basestation modulation diversity for digital SIMULCAST*. In *Vehicle Technology Conference, 1991. Gateway to the Future Technology in Motion., 41st IEEE*, pages 848–853, May 1991.
- [43] R. Xu and F.C.M. Lau. *Performance analysis for MIMO systems using zero forcing detector over fading channels*. volume 153, pages 74–80. IEE Proc.-Commun., February 2006.
- [44] Wei Zhang and Khaled Ben Letaief. *Opportunistic Relaying for Dual-Hop Wireless MIMO Channels*. pages 1–5. Global Telecommunications Conference, 2008. IEEE GLOBECOM 2008. IEEE, Nov. 30 2008 -Dec. 4 2008.
- [45] Gan Zheng, Symeon Chatzinotas, and Björn Otterstern. *Generic Optimization of Linear Precoding in Multibeam Satellite Systems*. IEEE Transactions on Wireless Communications, June 2012.