

10 major detainable deficiencies

1. Corrosion and holes on Launching Appliance



Inspection Point

- Corrosion on davit and foundation, which had been covered by paint coating.
- The coat of paint covering suspect area shall be removed for inspection.
- Bolt/Nut to be renewed as the evidence of repair, if necessary.

2. Poor condition of Launching arrangements

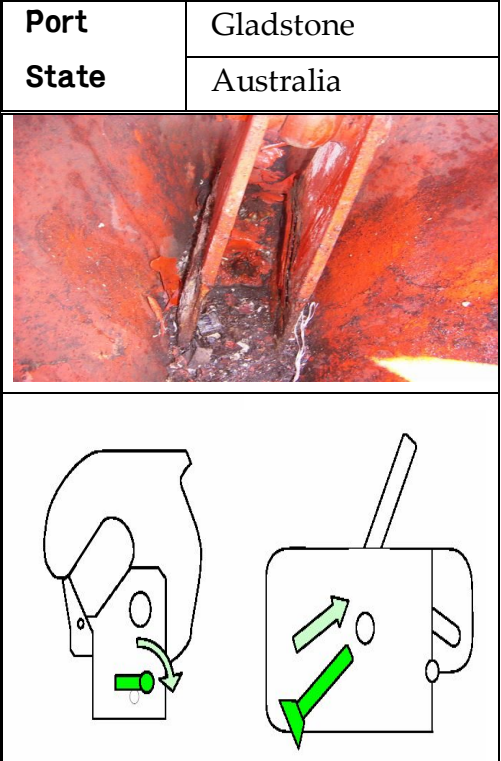
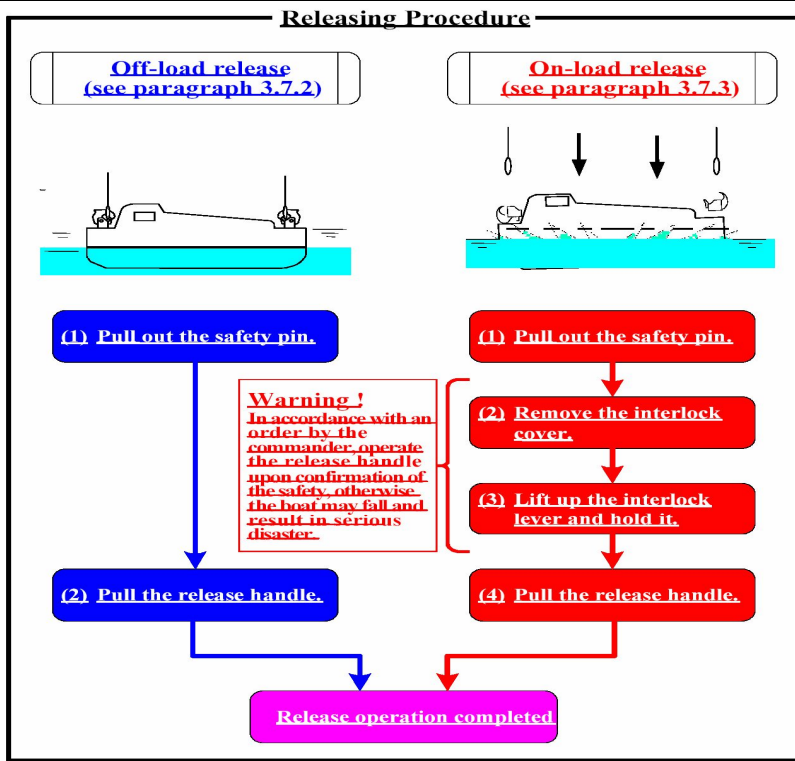

Inspection Point

- Inspection after removing the lifeboat inventory and the scale near the bracket.
- Working and set condition of On-load release gear system to be inspected.
- Close-up inspection on conditions of Block Sheave, Joint Shackle, etc.

3. Malfunction of Life Boat Engine

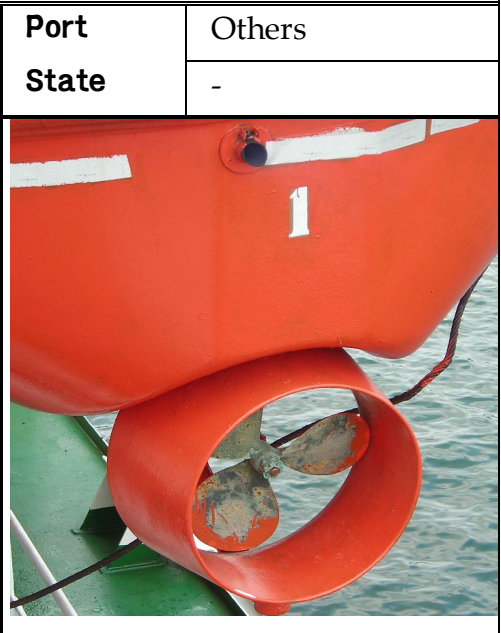

Inspection Point	➤ Confirmation of engine on each lifeboat to be started by one person
	➤ Cleaning of the F.O.T for removal of residue inside
	➤ Inspection on the chain condition, if necessary
	➤ Conducting the propeller test (Fwd/Aft direction)

4. Poor condition of Air Vent Head

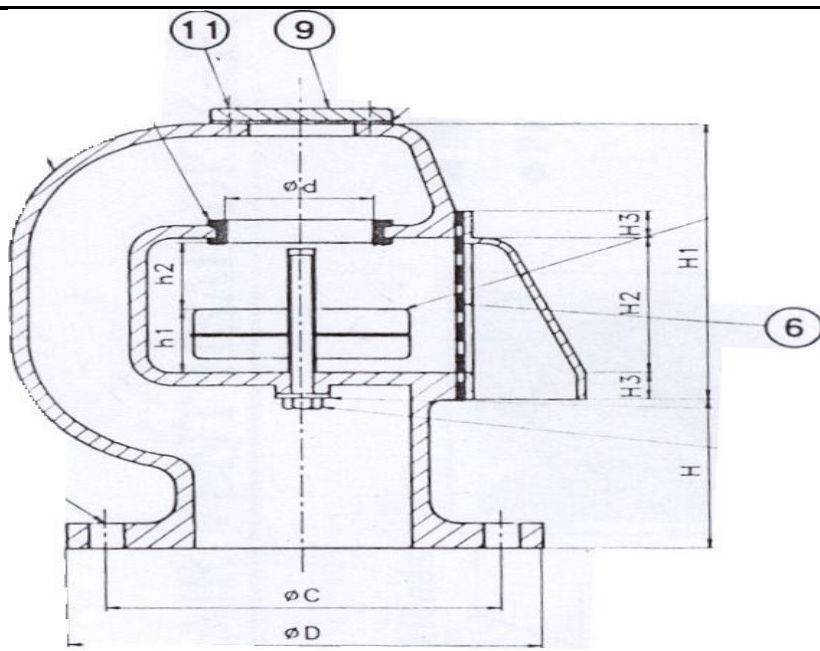

Inspection Point	➤ Inspection on the inside of Air Pipe Head conditions by removing the Cover
	➤ Check on the Pipe condition on exposed deck (corrosion, hole, etc.)
	➤ Check on cover-tightness for Gooseneck Type

5. Corrosion on Hatch Cleat Secure Socket

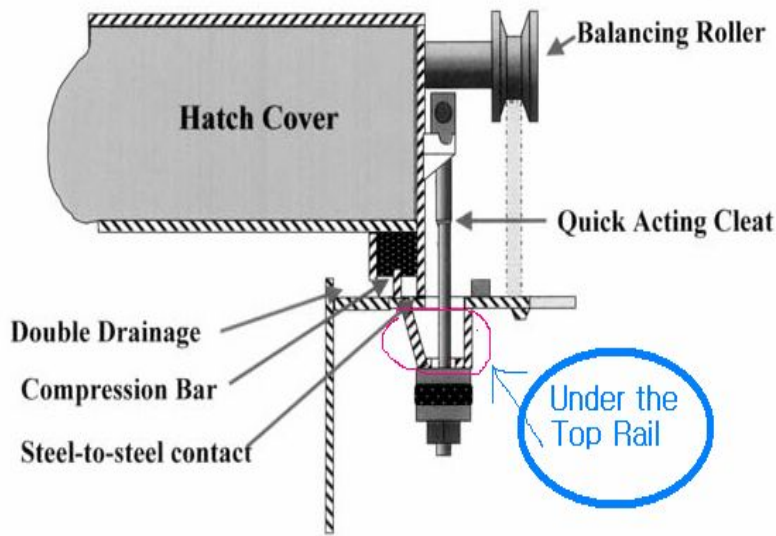

Port	Swansea / Gladstone
State	U.K. / Australia



- | | |
|------------------|--|
| Inspection Point | <ul style="list-style-type: none"> ➤ Check on the weather-tightness of hatch covers (hose test, if necessary) ➤ Check on the condition of Top Rail and the Cleat Socket installed below ➤ Cleat clearance to be checked, especially for Auto Cleat Type
(Ex. Maker Standard for MacGREGOR type is to be less than 3 mm) |
|------------------|--|

6. Malfunction of GMDSS Equipment



Port	-
State	Australia





```

* Received message at MAY-10-2008-08:33:25 *
FORMAT :INDIVIDUAL CALL
ADDRESS :477079100
CATEGORY :SAFETY
SELF-IDENTITY :004122100
1st TELECOMMAND :TEST
2nd TELECOMMAND :NO INFORMATION
WORKING FREQUENCY :ACK.BG
END OF SEQUENCE :ACK.BG
ERROR-CHECK :OK
    
```



* Sent message (ACK.RQ) to be checked as well

- | | |
|------------------|---|
| Inspection Point | <ul style="list-style-type: none"> ➤ Record for MF/HF DSC messages(BQ/RQ) to be available on board ➤ GMDSS equipment readiness for receiving relevant information to be checked ➤ Functioning test of reserve energy source (DC / Battery) for GMDSS equipment to be conducted |
|------------------|---|

7. Corrosion and hole on Hatch Coaming Stiffener

	Port 	
	State 	
		
Inspection Point	<ul style="list-style-type: none"> ➤ The original thickness to be checked, and the wear-down limits to be compared with measured one, if necessary ➤ Local area with holes to be inspected ➤ All deficiencies found during the Survey to be rectified before departure 	

8. Poor condition of Fire Damper/ Ventilator

	Port 	Singapore
	State 	Singapore
		
Inspection Point	<ul style="list-style-type: none"> ➤ Operation of moving parts for dampers to be checked (not to be stuck) ➤ Damper condition located inside ventilator to be examined through lowering head with lantern or removing cover (corroded due to temperature difference) ➤ Vent pipe to be inspected with removing scale, and inside of pipe, if necessary 	

9. Malfunction of Em'cy Fire Pump

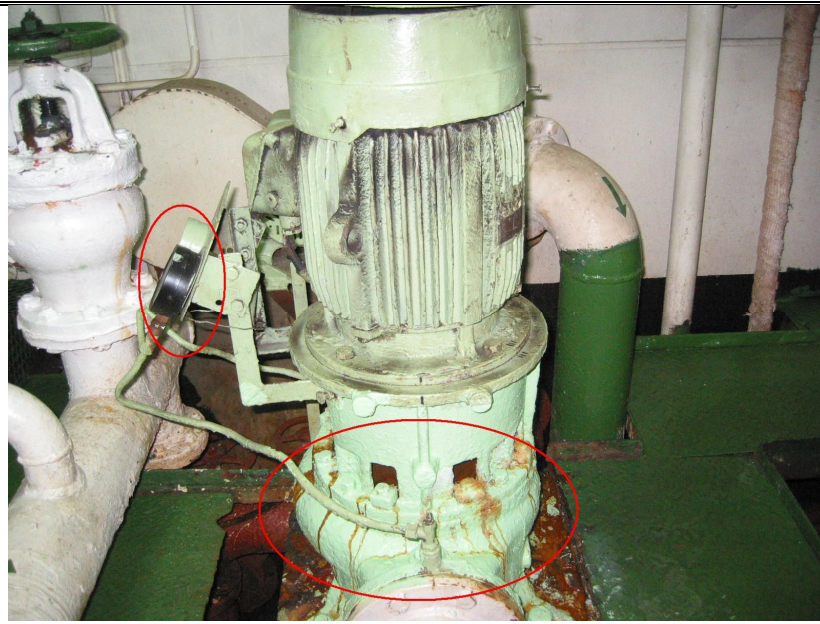

Port	Others
State	-

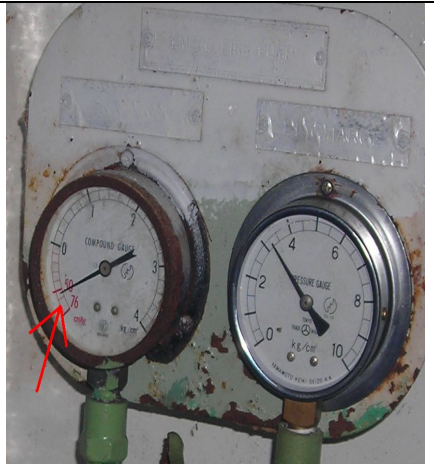

<p>Inspection Point</p>	<ul style="list-style-type: none"> ➤ Suction pressure (over -50Bar), Delivery pressure (3Kg/Cm²) to be checked ➤ Capable of delivering at least two required jets of water, in any case ➤ Running the pump more than 5 minutes with maximum pressure
--------------------------------	--

10. Malfunction of OWS

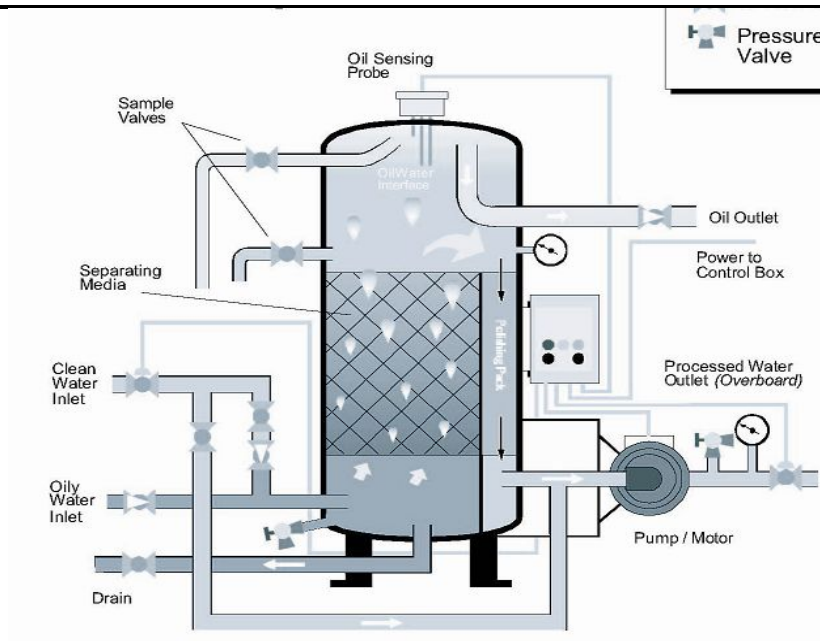

Port	Others
State	-



<p>Inspection Point</p>	<ul style="list-style-type: none"> ➤ Functioning of bilge alarm, oil level detector to be checked ➤ Oil existence inside the disassembled overboard outlet to be checked ➤ Functioning of oil discharge valve, three-way valve to be checked.
--------------------------------	--