



UNIVERSITY OF PIRAEUS - DEPARTMENT OF INFORMATICS

ΠΑΝΕΠΙΣΤΗΜΙΟ ΠΕΙΡΑΙΩΣ - ΤΜΗΜΑ ΠΛΗΡΟΦΟΡΙΚΗΣ

MSc «Development of an AI-Based System for Knowledge Specific Assistance»

ΠΜΣ «Ανάπτυξη ενός Συστήματος Τεχνητής Νοημοσύνης για Υποβοήθηση σε Συγκεκριμένη Γνώση»

MSc Thesis

Μεταπτυχιακή Διατριβή

Thesis Title: Τίτλος Διατριβής:	Development of an AI-Based System for Knowledge Specific Assistance Ανάπτυξη ενός Συστήματος Τεχνητής Νοημοσύνης για Υποβοήθηση σε Συγκεκριμένη Γνώση
Student's name-surname: Όνοματεπώνυμο φοιτητή:	Apostolou Athanasios Αποστόλου Αθανάσιος
Father's name: Πατρώνυμο:	Christos Χρήστος
Student's ID No: Αριθμός Μητρώου:	ΜΠΣΠ2203
Supervisor: Επιβλέπων:	Dionisios Sotiropoulos, Assistant Professor Διονύσιος Σωτηρόπουλος, Επίκουρος Καθηγητής

October 2024/ Οκτώβριος 2024

3-Member Examination Committee

Τριμελής Εξεταστική Επιτροπή

Dionisios Sotiropoulos
Assistant Professor

Διονύσιος Σωτηρόπουλος
Επίκουρος Καθηγητής

Tsichrintzis Georgios
Professor

Τσιχριντζής Γεώργιος
Καθηγητής

Sakkopoulos Evangelos
Associate Professor

Σακκόπουλος Ευάγγελος
Αναπληρωτής Καθηγητής

Contents

Abstract	4
1. Introduction	5
1.1. Theory and Literature Review	5
1.1.1. Artificial intelligence	5
1.1.2. Machine Learning	6
1.1.3. Text Generation Models, LLM	8
1.1.4. Retrieval Augmented Generation (RAG)	11
1.2. Sections	13
2. Technologies	14
2.1. Python Programming Language	14
2.2. Rust Programming Language	16
2.3. Python Libraries	17
2.4. Rust Libraries	19
2.5. HTML, CSS, SPA, Typescript, Vue.js	20
2.6. Containers, Docker and Kubernetes	21
3. Specific Knowledge Assistance Approaches	25
3.1. Custom Text Generation Model Method	25
3.1.1. Method Description	25
3.1.2. Method Advantages and Disadvantages	30
3.2. Retrieval Augmented Generation (RAG) Method	30
3.2.1. Method Description	30
3.2.2. Method Advantages and Disadvantages	33
4. System Architecture	34
4.1. System Components	34
4.2. Development Lifecycle and Deployment	40
5. Usage and Execution of the Application	42
5.1. Command Line Interface (CLI) Usage	42
5.2. Graphical User Interface (GUI) Usage	47
6. Conclusions and Future Work	55
Bibliography	57

Abstract

This MSc thesis is about utilizing artificial intelligence models in order to find specific knowledge. As part of this goal we will develop a complete web application, where users will be able to ask questions to artificial intelligence models, which will answer them based on a specific context. We will follow two different methods. For the first method we will create our own text generation AI model [1] which will be trained to understand specific knowledge. For the second method we will use existing artificial intelligence models, trying to limit them so that they respond only to the specific knowledge context that we have chosen. In the end we will be able to come to conclusions about the usefulness of these methods.

Περίληψη

Η παρούσα μεταπτυχιακή εργασία ασχολείται με την αξιοποίηση μοντέλων τεχνητής νοημοσύνης για την υποβοήθηση ανεύρεσης συγκεκριμένης γνώσης. Στα πλαίσια αυτού του στόχου θα αναπτύξουμε μια πλήρη διαδικτυακή εφαρμογή, στην οποία οι χρήστες θα μπορούν να κάνουν ερωτήσεις σε μοντέλα τεχνητής νοημοσύνης, τα οποία θα τους απαντάνε με βάση συγκεκριμένο πλαίσιο. Θα ακολουθήσουμε δύο διαφορετικές μεθόδους. Για την πρώτη μέθοδο θα δημιουργήσουμε ένα δικό μας μοντέλο τεχνητής νοημοσύνης παραγωγής κειμένου [1] το οποίο θα εκπαιδευτεί για να κατανοεί συγκεκριμένη γνώση. Για την δεύτερη μέθοδο θα χρησιμοποιήσουμε υπάρχοντα μοντέλα τεχνητής νοημοσύνης προσπαθώντας να τα περιορίσουμε ώστε να απαντάνε μόνο στο συγκεκριμένο πλαίσιο γνώσης που έχουμε επιλέξει. Στο τέλος θα μπορέσουμε να καταλήξουμε σε συμπεράσματα για την χρησιμότητα αυτών των μεθόδων.

1. Introduction

In our era, the knowledge we have acquired is bigger than ever. The number of books, notes, web pages and other forms of content keeps increasing year by year. It is impossible for any human being, to be able to read an process all this available knowledge. Fortunately, technology has been greatly improved and is being used daily for tasks involving knowledge search and analysis. While traditional tools like search engines made it easier for us to find existing knowledge, in the past years we have observed the increasing development of tools using artificial intelligence. We will study the usage of text generation machine learning models in specific knowledge search and analysis assistance. We will use two different methods for these tasks and we will develop a full web application with which users will be able to ask questions

1.1. Theory and Literature Review

The fundamental theoretic concepts of this thesis stem from the study field of artificial intelligence. We will describe the connection between artificial intelligence, machine learning and deep learning. We will focus on a specific category of machine learning models involving text generation and the state of the art practices of utilizing their capabilities to the maximum by using Retrieval Augmented Generation (RAG) technique.

1.1.1. Artificial intelligence

In the general sense, Artificial intelligence (AI) is about machines, like computer systems, showing intelligence in a degree similar to humans. It is a field of research in computer science that develops and studies methods and software that enable machines to perceive their environment and use learning and intelligence to take actions that maximize their chances of achieving defined goals [2]. The machines which fit this description can be called AIs.

Intelligence can be considered to be a property of internal thought processes and reasoning, or a property of intelligent behavior, an external characterization. From these two dimensions (human vs. rational and thought vs. behavior) there are four possible combinations. The methods used are necessarily different: the pursuit of human-like intelligence must be in part an empirical science related to psychology, involving observations and hypotheses about actual human behavior and thought processes; a rationalist approach, on the other hand, involves a combination of mathematics and engineering, and connects to statistics, control theory, and economics. These 4 approaches are the following: [3]

- Acting humanly: The Turing test approach The Turing test, proposed by Alan Turing (1950) and it consists of 4 core principles that a computer would need to follow in order to pass it.
 - natural language processing to communicate successfully in a human language
 - knowledge representation to store what it knows or hears
 - automated reasoning to answer questions and to draw new conclusions
 - machine learning to adapt to new circumstances and to detect and extrapolate patterns

The full Turing test is completed with 2 additional characteristics which have been added by later researchers:

- computer vision and speech recognition to perceive the world
- robotics to manipulate objects and move themselves
- Thinking humanly: The cognitive modeling approach We can determine if a computer or a program thinks like a human by analyzing the human thought in 3 main concepts:

- introspection - trying to catch our own thoughts as they go by
- psychological experiments - observing a person in action
- brain imaging - observing the brain in action
- Thinking rationally: The “laws of thought” approach Rationally thinking can be achieved by following the rules defined by the “logic” study field. When conventional logic requires knowledge that cannot be obtained realistically, then the theory of probability helps us define logical thinking.
- Acting rationally: The rational agent approach Rational thinking can achieve a construction of a comprehensive model of rational thought, but cannot generate intelligent behavior by itself. A rational agent is one that acts so as to achieve the best outcome or, when there is uncertainty, the best expected outcome.

1.1.2. Machine Learning

We described the fundamental concepts with which artificial intelligence is defined. Machine learning (ML) is a field of study in artificial intelligence concerned with the development and study of statistical algorithms that can learn from data and generalize to unseen data and thus perform tasks without explicit instructions. [4]

Machine learning is a subset of artificial intelligence (AI) focused on developing algorithms and statistical models that enable computers to perform tasks without explicit instructions. Instead, these systems learn and improve from experience by identifying patterns in data. Machine Learning uses algorithms and statistical models to enable computers to perform specific tasks without being explicitly programmed to do so. Machine learning systems learn from and make decisions based on data. The process involves the following steps:

- Data Collection: Gathering relevant data that the model will learn from.
- Data Preparation: Cleaning and organizing data to make it suitable for training.
- Model Selection: Choosing an appropriate algorithm that fits the problem.
- Training: Using data to train the model, allowing it to learn and identify patterns.
- Evaluation: Assessing the model's performance using different metrics.
- Optimization: Fine-tuning the model to improve its accuracy and efficiency.
- Deployment: Implementing the model in a real-world scenario for practical use.

There are 4 basic types of Machine Learning: [4]–[6]

- Supervised Learning: We have labeled data for which we know the correct output from the corresponding input. The machine learning model tries to find a mapping from inputs to outputs. Some examples of problems categories are Regression and Classification.
- Unsupervised Learning: We only have unlabeled data, meaning that we don't know the correct outputs for given inputs. The model must find hidden patterns or intrinsic structures in the input data. Some problems categories are Clustering, association.
- Semi-Supervised Learning: Combines a small amount of labeled data with a large amount of unlabeled data during training. It lays somewhere between supervised and unsupervised learning.
- Reinforcement Learning: The model learns by interacting with an environment, receiving rewards or penalties based on its actions, and aims to maximize the cumulative reward. Some examples are Game playing, robotic control.

Deep learning is a subset of machine learning that uses multilayered neural networks, called deep neural networks, to simulate the complex decision-making power of the human brain [7]. Deep learning is being used in order to teach computers how to process data in a way that is inspired by the human brain. Deep learning models can recognize complex patterns in pictures, text, sounds, and other data to produce accurate insights and predictions. Deep learning methods can be used in order to automate tasks that typically require human intelligence, such as describing images or transcribing a sound file into text [8]. We can visualize the subsets of Deep Learning, Machine Learning and Artificial Intelligence with the diagram below:

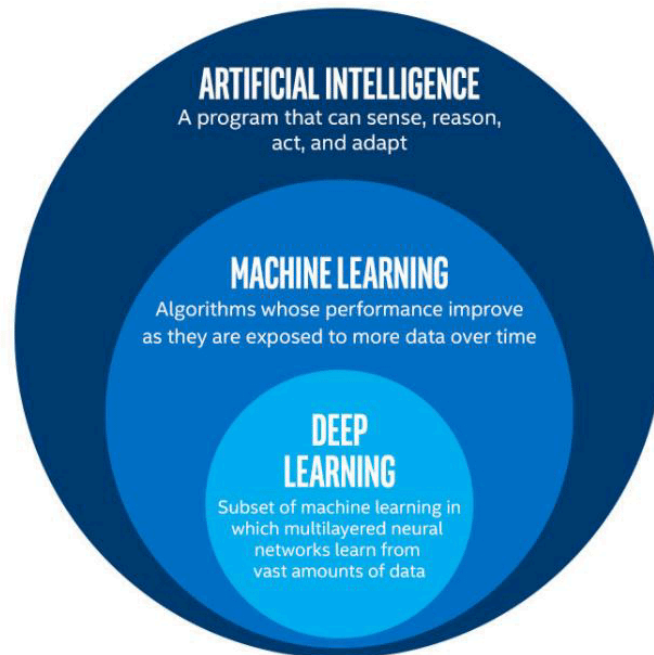

IMAGE 1: Venn Diagram for AI, ML, Deep Learning [9]

Artificial Intelligence, Machine Learning and Deep Learning are involved in many applications like Recommender Systems, Medical Diagnosis, Image Recognition, Speech Recognition, Email Spam and Malware Filtering, Traffic prediction, Self-driving cars, Virtual Personal Assistant, Fraud Detection, Stock Market trading, Automatic Language Translation, Chatbots, Generation of text images and videos. [10]–[12]. All these applications required different artificial intelligence disciplines that can be combined in order to create a complete artificial intelligence system which produces the required output.

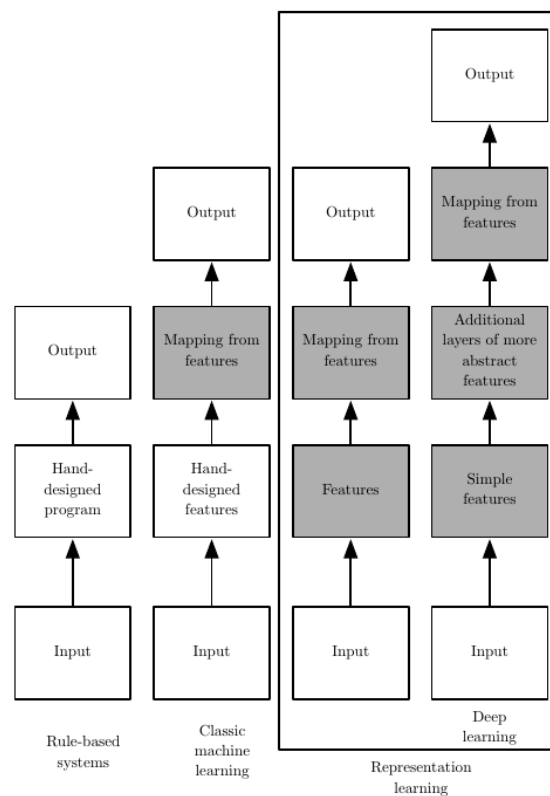

IMAGE 2: Flowcharts showing how the different parts of an AI system relate to each other within different AI disciplines. Shaded boxes indicate components that are able to learn from data. [13]

1.1.3. Text Generation Models, LLM

We described the fundamental concepts of artificial intelligence and machine learning. Now we will take a closer look into a specific category of machine learning models which are used in text generation tasks.

Generative AI refers to deep-learning models that can generate high-quality text, images, and other content based on the data they were trained on. [14]. A text generation model is a type of generative AI models which is designed to produce coherent and contextually relevant textual content. These models are typically based on natural language processing (NLP) techniques and are trained in text data to learn the patterns, grammar, and context required to generate human-like text. When these these models are trained in huge sets of data and have been fed enough examples to be able to recognize and interpret human language or other types of complex data, then they are called large language models (LLM) [15].

These are the key components and concepts of text generation models:

- Training Data:
 - Corpora: Large collections of text used to train the model. These can include books, articles, websites, dialogues, and other text sources.
 - Preprocessing: Cleaning and organizing the text data, including tokenization (breaking text into words or subwords), removing special characters, and normalizing text.
- Model Architecture:

- Recurrent Neural Networks (RNNs): Earlier models for text generation, including Long Short-Term Memory (LSTM) and Gated Recurrent Units (GRUs), which handle sequential data by maintaining context over time.
- Transformers: Modern architecture that has become the standard for NLP tasks. Transformers use self-attention mechanisms to process entire sequences of text at once, allowing for better handling of context and dependencies over long distances in the text. Examples include the GPT (Generative Pre-trained Transformer) series, BERT (Bidirectional Encoder Representations from Transformers), and others.
- Training Process:
 - Unsupervised Learning: Most text generation models are trained using unsupervised learning, where the model learns to predict the next word or sequence of words based on the context provided by preceding text.
 - Fine-Tuning: After pre-training on a large corpus, models are often fine-tuned on specific datasets to adapt them to particular tasks or domains.
- Generation Techniques:
 - Sampling: Randomly selecting the next word from the probability distribution generated by the model.
 - Beam Search: An algorithm that searches for the best sequence of words by considering multiple candidate sequences at each step and selecting the most likely ones.
 - Temperature Adjustment: Modifying the probability distribution to control the randomness of the generated text. Lower temperatures result in more deterministic outputs, while higher temperatures produce more diverse and creative text.

Usually the most popular LLMs have these parameters in order to control sampling. Parameter “top_k” limits the model’s output to the top-k most probable tokens at each step. This can help reduce incoherent or nonsensical output by restricting the model’s vocabulary. Parameter “top_p” filters out tokens whose cumulative probability is less than a specified threshold (p). It allows for more diversity in the output while still avoiding low-probability tokens. Temperature adjusts the randomness or confidence level of the model’s predictions by scaling the log probabilities. Higher temperatures lead to more diverse but potentially nonsensical outputs, while lower temperatures yield more focused and predictable responses [16], [17].

- Evaluation:
 - Perplexity: A measure of how well a probability model predicts a sample. Lower perplexity indicates better performance.
 - Human Evaluation: Assessing the coherence, relevance, and fluency of the generated text through human judges.
 - Automated Metrics: BLEU (Bilingual Evaluation Understudy), ROUGE (Recall-Oriented Understudy for Gisting Evaluation), and other metrics comparing the generated text to reference texts.

Due to the fact that pre-trained LLMs are huge in size and their invocation requires huge amounts of memory, most popular LLMs are converted using some quantization technique. Quantization is a model compression technique that converts the weights and activations within an LLM from a high-precision data representation to a lower-precision data representation, i.e., from a data type that can hold more information to one that holds less. A typical example of this is the conversion of data from a 32-bit floating-point number (FP32) to an 8-bit or 4-bit integer (INT4 or INT8). [18] There are two popular types of LLM Quantization: PTQ and QAT [18]

- **Post-Training Quantization (PTQ):** this refers to techniques that quantize an LLM after it has already been trained. PTQ is easier to implement than QAT, as it requires less training data and is faster. However, it can also result in reduced model accuracy from lost precision in the value of the weights.
- **Quantization-Aware Training (QAT):** this refers to methods of fine-tuning on data with quantization in mind. In contrast to PTQ techniques, QAT integrates the weight conversion process, i.e., calibration, range estimation, clipping, rounding, etc., during the training stage. This often results in superior model performance, but is more computationally demanding.

Some advantages of LLM quantization are: [18]

- **Smaller Models:** by reducing the size of their weights, quantization results in smaller models. This allows them to be deployed in a wider variety of circumstances such as with less powerful hardware; and reduces storage costs.
- **Increased Scalability:** the lower memory footprint produced by quantized models also makes them more scalable. As quantized models have fewer hardware constraints, organizations can feasibly add to their IT infrastructure to accommodate their use.
- **Faster Inference:** the lower bit widths used for weights and the resulting lower memory bandwidth requirements allow for more efficient computations.

However the disadvantages are [18]:

- **Loss of Accuracy:** The most significant disadvantage of quantization is loss of accuracy in output. Converting the model's weights to a lower precision is likely to degrade its performance. The more "aggressive" the quantization technique, i.e. the lower the bit widths of the converted data type, e.g., 4-bit, 3-bit, etc., the greater the risk of loss of accuracy.

Some techniques for LLM quantization are the following [18]:

- **QLoRA: Low-Rank Adaptation (LoRA)** is a Parameter-Efficient Fine-Tuning (PEFT) technique that reduces the memory requirements of further training a base LLM by freezing its weights and fine-tuning a small set of additional weights, called adapters. Quantized Low-Rank Adaptation (QLoRA) takes this a step further by quantizing the original weights within the base LLM to 4-bit: reducing the memory requirements of an LLM to make it feasible to run on a single GPU.
- **PRILoRA: Pruned and Rank-Increasing Low-Rank Adaptation (PRILoRA)** is a fine-tuning technique recently proposed by researchers that aims to increase LoRA efficiency through the introduction of two additional mechanisms: the linear distribution of ranks and ongoing importance-based A-weight pruning.
- **GPTQ: General Pre-Trained Transformer Quantization (GPTQ)** is a quantization technique designed to reduce the size of models so they can run on a single GPU. GPTQ works through a form of layer-wise quantization: an approach that quantizes a model a layer at a time, with the aim of discovering the quantized weights that minimize output error (the mean squared error (MSE), i.e., the squared error between the outputs of the original, i.e., full-precision, layer and the quantized layer.)
- **GGML/GGUF: GGML** (which is said to stand for Georgi Gerganov Machine Learning, after its creator, or GPT-Generated Model Language) is a C-based machine learning library designed for the quantization of Llama models so they can run on a CPU. More specifically, the library allows us to save quantized models in the GGML binary format, which can be executed on a broader range of hardware. GGML quantizes models through a process called the k-quant system, which uses value representations of different bit widths depending on the chosen quant method. First, the model's weights are divided into blocks of 32: with each block having a scaling factor based on the largest weight value, i.e., the highest gradient magnitude. Depending on the selected

quant-method, the most important weights are quantized to a higher-precision data type, while the rest are assigned to a lower-precision type. For example, the q2_k quant method converts the largest weights to 4-bit integers and the remaining weights to 2-bit. Alternatively, however, the q5_0 and q8_0 quant methods convert all weights to 5-bit and 8-bit integer representations respectively. We can view GGML's full range of quant methods by looking at the model cards in this code repo. GGUF (GPT-Generated Unified Format), meanwhile, is a successor to GGML and is designed to address its limitations, most notably, enabling the quantization of non-Llama models. GGUF is also extensible: allowing for the integration of new features while retaining compatibility with older LLMs.

- AWQ: Conventionally, a model's weights are quantized irrespective of the data they process during inference. In contrast, Activation-Aware Weight Quantization (AWQ) accounts for the activations of the model, i.e., the most significant features of the input data, and how it is distributed during inference. By tailoring the precision of the model's weights to the particular characteristic of the input, we can minimize the loss of accuracy caused by quantization.

1.1.4. Retrieval Augmented Generation (RAG)

Retrieval Augmented Generation (RAG) is a technique for augmenting LLM knowledge with additional data. LLMs can reason about wide-ranging topics, but their knowledge is limited to the public data up to a specific point in time that they were trained on. If we want to build AI applications that can reason about private data or data introduced after a model's cutoff date, we need to augment the knowledge of the model with the specific information it needs. The process of bringing the appropriate information and inserting it into the model prompt is known as Retrieval Augmented Generation (RAG) [19]. RAG extends the already powerful capabilities of LLMs to specific domains or an organization's internal knowledge base, all without the need to retrain the model. It is a cost-effective approach to improving LLM output so it remains relevant, accurate, and useful in various contexts [20].

RAG is important because of these reasons [20]:

- LLMs have known drawbacks:
 - Presenting false information when it does not have the answer.
 - Presenting out-of-date or generic information when the user expects a specific, current response.
 - Creating a response from non-authoritative sources.
 - Creating inaccurate responses due to terminology confusion, wherein different training sources use the same terminology to talk about different things
- RAG comes with additional benefits:
 - Cost-effective implementation: The computational and financial costs of retraining text generation model for organization or domain-specific information are high. RAG is a more cost-effective approach to introducing new data to the LLM.
 - Current information: RAG allows developers to provide the latest research, statistics, or news to the generative models. They can use RAG to connect the LLM directly to live social media feeds, news sites, or other frequently-updated information sources. The LLM can then provide the latest information to the users.
 - Enhanced user trust: RAG allows the LLM to present accurate information with source attribution. The output can include citations or references to sources. Users can also look

up source documents themselves if they require further clarification or more detail. This can increase trust and confidence in our generative AI solution.

- More developer control: With RAG, developers can test and improve their chat applications more efficiently. They can control and change the LLM’s information sources to adapt to changing requirements or cross-functional usage. Developers can also restrict sensitive information retrieval to different authorization levels and ensure the LLM generates appropriate responses. In addition, they can also troubleshoot and make fixes if the LLM references incorrect information sources for specific questions. Organizations can implement generative AI technology more confidently for a broader range of applications.

A typical RAG application has two main components [19]:

- Indexing: a pipeline for ingesting data from a source and indexing it. This usually happens offline.
 - Load: First we need to load our data. This is done with Document Loaders.
 - Split: Text splitters break large Documents into smaller chunks. This is useful both for indexing data and for passing it in to a model, since large chunks are harder to search over and won’t fit in a model’s finite context window.
 - Store: We need somewhere to store and index our splits, so that they can later be searched over. This is often done using a Vector Store and Embeddings model.
- Retrieval and generation: the actual RAG chain, which takes the user query at run time and retrieves the relevant data from the index, then passes that to the model.
 - Retrieve: Given a user input, relevant splits are retrieved from storage using a Retriever.
 - Generate: A ChatModel / LLM produces an answer using a prompt that includes the question and the retrieved data

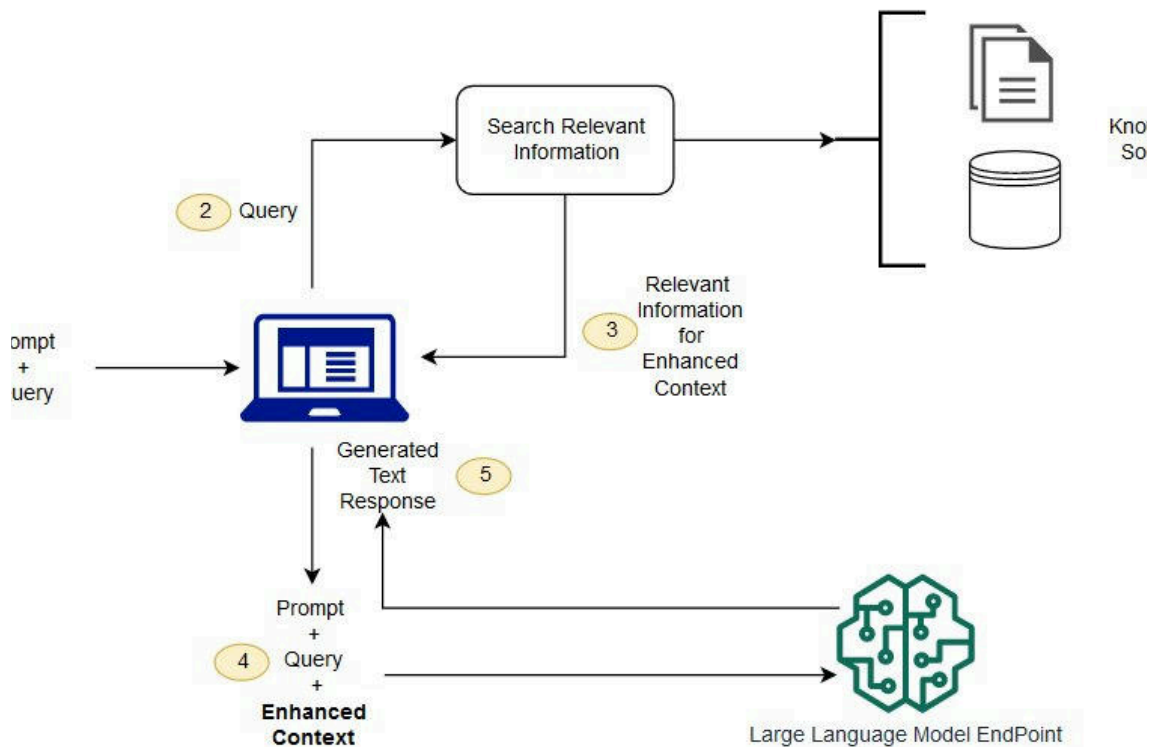

IMAGE 3: Conceptual flow of using RAG with LLMs. [20]

1.2. Sections

Lets describe briefly the next sections of this thesis.

In Section 2 we will describe the various technologies and their advantages, which we will use for our application development and deployment.

In Section 3 we will dive in the details of the two methods that we will use. We will compare them and we will describe their advantages and disadvantages.

In Section 4 we will describe the architecture and the implementation of our application. We will show the components which construct our application, the tasks each component can perform and how they are connected together.

In Section 5 we will show the design and execution results of our deployed application. We will investigate the various ways in which our application can be used by the users in order to find specific knowledge based on raw data like documents or web pages.

In Section 6 we will write our conclusions we reached. We will describe the problems and limitations we faced. Finally, we will specify future improvements that can be made as well as future goals about scaling and expand the core idea.

2. Technologies

In this chapter we will describe the main technologies which we will use for the development and deployment of our system.

In the context of this thesis we will use many technologies in order to produce a complete application. We will describe the main programming languages we used for this application, Rust and Python. We will see more details about the core programming libraries our application is using and their basic features we utilize. Finally we will talk about the state of the art deployment procedure of deployments based on containers utilization.

2.1. Python Programming Language

Python is a high-level, general-purpose programming language. Its design philosophy emphasizes code readability with the use of significant indentation. Python is dynamically typed and garbage-collected. It supports multiple programming paradigms, including structured (particularly procedural), object-oriented and functional programming. It is often described as a “batteries included” language due to its comprehensive standard library. [21]

Choosing python as a programming language has several benefits [22]

- Python has easy English-like syntax that, so it is easier for developers to read a code base understand it.
- Python software usually can be written with fewer lines of code comparing to other programming languages, so it can increase development productivity.
- Python has a large standard library which covers multiple tasks like cli parsing, http clients, advanced mathematics, etc. Developers can utilize the standard library without the need to use third party libraries or write code from scratch.
- Python can easily be used by developers with other popular programming languages such as Java, C, and C++ and Rust.
- Python has one of the most active communities of developers. So, it makes it easier for developers to find quick support for almost every task needed. There are also many helpful resources like videos, tutorials, documentation, and developer guides available on the internet.
- Python can be use in many operating systems such as Windows, macOS, Linux, and Unix since it is portable.

The python programming language is very popular in various applications: [22]

- Server-side web development: Server-side web development includes the complex backend functions that websites perform to display information to the user. For example, websites must interact with databases, talk to other websites, and protect data when sending it over the network.
- Graphical User Interfaces development (GUI): Develop user friendly GUI applications while also providing a good user experience.
- Gaming development: Python can be used to develop games. Popular python libraries exist for both 2D and 3D graphics development.
- Automation with Python scripts: A scripting language is a programming language that automates tasks that humans normally perform. Such tasks usually include:
 - filesystem operations like files renaming, reading, writing, converting.
 - Mathematical operations
 - download content

- text operations and transformations in files
- basic log analysis
- Data science and machine learning: Data science is extracting valuable knowledge from data, and machine learning (ML) teaches computers to automatically learn from the data and make accurate predictions.
- Software deployments and operations: Python can be used for different development tasks and software applications such as:
 - Automatically building the software
 - Utilize continuous integration and continuous deployments (CI/CD)
 - Handling software project management
- Software test automation: Check whether the actual results from the software match the expected results to ensure that the software is error-free.

Using python programming language has various advantages [23]:

- Presence of third-party modules: Python has a rich ecosystem of third-party modules and libraries that extend its functionality for various tasks.
- Extensive support libraries: Python boasts extensive support libraries like NumPy for numerical calculations and Pandas for data analytics, making it suitable for scientific and data-related applications.
- Open source and large active community base: Python is open source, and it has a large and active community that contributes to its development and provides support.
- Versatile, easy to read, learn, and write: Python is known for its simplicity and readability, making it an excellent choice for both beginners and experienced programmers.
- User-friendly data structures: Python offers intuitive and easy-to-use data structures, simplifying data manipulation and management.
- High-level language: Python is a high-level language that abstracts low-level details, making it more user-friendly.
- Dynamically typed language: Python is dynamically typed, meaning we don't need to declare data types explicitly, making it flexible but still reliable.
- Object-Oriented and Procedural programming language: Python supports both object-oriented and procedural programming, providing versatility in coding styles.
- Portable and interactive: Python is portable across operating systems and interactive, allowing real-time code execution and testing.
- Ideal for prototypes: Python's concise syntax allows developers to prototype applications quickly with less code.
- Highly efficient: Python's clean design provides enhanced process control, and it has excellent text processing capabilities, making it efficient for various applications.
- Internet of Things (IoT) opportunities: Python is used in IoT applications due to its simplicity and versatility.
- Interpreted language: Python is interpreted, which allows for easier debugging and code development.

However python programming language has also some drawbacks [23]:

- Performance: Python is an interpreted language, which means that it can be slower than compiled languages like C or Java. This can be an issue for performance-intensive tasks.

- **Global Interpreter Lock:** The Global Interpreter Lock (GIL) is a mechanism in Python that prevents multiple threads from executing Python code at once. This can limit the parallelism and concurrency of some applications.
- **Memory consumption:** Python can consume a lot of memory, especially when working with large datasets or running complex algorithms.
- **Dynamically typed:** Python is a dynamically typed language, which means that the types of variables can change at runtime. This can make it more difficult to catch errors and can lead to bugs.
- **Packaging and versioning:** Python has a large number of packages and libraries, which can sometimes lead to versioning issues and package conflicts.
- **Lack of strictness:** Python's flexibility can sometimes be a double-edged sword. While it can be great for rapid development and prototyping, it can also lead to code that is difficult to read and maintain.

2.2. Rust Programming Language

Rust is a general-purpose programming language emphasizing performance, type safety, and concurrency. It enforces memory safety, meaning that all references point to valid memory, without a garbage collector. To simultaneously enforce memory safety and prevent data races, its "borrow checker" tracks the object lifetime of all references in a program during compiling. Rust was influenced by ideas from functional programming, including immutability, higher-order functions, and algebraic data types. It is popular for systems programming. Rust does not enforce a programming paradigm, but supports object-oriented programming via structs, enums, traits, and methods, and supports functional programming via immutability, pure functions, higher order functions, and pattern matching. [24]

Rust programming languages can be used in many applications [25], [26]:

- **Server-side web development:** Rust can be used to write simple REST APIs or even full stack backend applications which connect to databases and serve complex HTML pages using various template engines.
- **Client-side web development:** Rust can be compile to WebAssembly and be used to create client side web applications supported in all modern web browsers.
- **Graphical User Interfaces development (GUI):** Develop user friendly GUI applications while also providing a good user experience. Rust GUI frameworks can use different architecture including Elm, immediate mode, reactive and others.
- **Gaming development:** Rust can be used to develop games. New modern rust libraries have emerged for both 2D and 3D graphics development.
- **Embedded development:** Due to low resource usage and high performance, rust can be used to develop applications for low resource devices.
- **Command line development:** Rust can be used to create both command line interfaces (CLI) as well as terminal user interfaces (TUI).
- **Internet of Things development (IoT):** IoT devices typically have limited resources, and Rust's memory safety and low-level control make it an excellent choice for developing embedded systems.
- **Robotics:** Robotics requires real-time processing, and Rust's low-level control and memory safety make it ideal for developing real-time applications. Rust's concurrency features make it possible to handle multiple threads efficiently, which is essential in robotics applications.

- **Machine Learning:** Rust libraries and ecosystem for machine learning development is newer and currently more limited than Python's. However rust can be preferred for its higher performance, the memory safety and its immutability features.

Using rust programming language has various advantages [27]:

- **Memory Safety:** Rust's borrow checker ensures memory safety without the overhead of garbage collection. This means fewer memory leaks and crashes.
- **Performance:** Comparable to C and C++, Rust provides fine-grained control of memory and other resources.
- **Concurrency:** Rust's ownership model makes concurrent programming more manageable and less prone to bugs.
- **Modern Tooling:** Cargo, Rust's package manager and build system, is highly praised for its ease of use.
- **Vibrant Community:** Rust has a growing and enthusiastic community, which results in good documentation, community support, and an expanding ecosystem.

However rust programming language has also some drawbacks [27]:

- **Steep Learning Curve:** Rust's unique features, like ownership and lifetimes, can be challenging to grasp for newcomers.
- **Compilation Time:** Rust programs can have longer compile times compared to some other languages.
- **Lesser Library Support:** While growing, the Rust ecosystem is still smaller than those of older languages like C++, Java or Python.

2.3. Python Libraries

We will talk about the most important Python libraries that we use for our application and their important parts that we utilize.

One of the most significant libraries we use is **NLTK**. NLTK is a leading platform for building Python programs to work with human language data. It provides easy-to-use interfaces to over 50 corpora and lexical resources such as WordNet, along with a suite of text processing libraries for classification, tokenization, stemming, tagging, parsing, and semantic reasoning, wrappers for industrial-strength NLP libraries, and an active discussion forum. Thanks to a hands-on guide introducing programming fundamentals alongside topics in computational linguistics, plus comprehensive API documentation, NLTK is suitable for linguists, engineers, students, educators, researchers, and industry users alike. NLTK is available for Windows, Mac OS X, and Linux. Moreover, NLTK is a free, open source, community-driven project [28]. NLTK comes with many corpora, toy grammars, trained models, etc which are called NLTK Data [29]. One of the most important modules of NLTK is the "tokenize" module which can help us split a long text into sentences or into words.

In order to create our own machine learning model we will use **PyTorch** library. PyTorch is a machine learning library based on the Torch library, used for applications such as computer vision and natural language processing [30]. Written in Python, it's relatively easy for most machine learning developers to learn and use. PyTorch is distinctive for its excellent support for GPUs and its use of reverse-mode auto-differentiation, which enables computation graphs to be modified on the fly. The most fundamental concepts of pytorch are Tensors and Graphs. Tensors are a

core PyTorch data type, similar to a multidimensional array, used to store and manipulate the inputs and outputs of a model, as well as the model's parameters. Tensors are similar to NumPy's ndarrays, except that tensors can run on GPUs to accelerate computing. Graphs are data structures consisting of connected nodes (called vertices) and edges. Every modern framework for deep learning is based on the concept of graphs, where Neural Networks are represented as a graph structure of computations. PyTorch keeps a record of tensors and executed operations in a directed acyclic graph (DAG) consisting of Function objects. In this DAG, leaves are the input tensors, roots are the output tensors. [31]

In order to use existing pre-trained Large Language Models (LLM), which we described in Section 1.1.3, we will use **LangChain**. LangChain is a framework for developing applications powered by large language models (LLMs). LangChain simplifies every stage of the LLM application lifecycle [32]:

- **Development:** Build our applications using LangChain's open-source building blocks, components, and third-party integrations. Use LangGraph to build stateful agents with first-class streaming and human-in-the-loop support.
- **Productionization:** Use LangSmith to inspect, monitor and evaluate our chains, so that we can continuously optimize and deploy with confidence.
- **Deployment:** Turn our LangGraph applications into production-ready APIs and Assistants with LangGraph Cloud.

LangChain does not serve its own LLMs, but rather provides a standard interface for interacting with many different LLMs. To be specific, this interface is one that takes as input a string and returns a string. There are lots of LLM providers (OpenAI, Cohere, Hugging Face, Llama.cpp, etc), the LLM class is designed to provide a standard interface for all of them. [33] LangChain provides also integration with vector stores. One of the most common ways to store and search over unstructured data is to embed it and store the resulting embedding vectors, and then at query time to embed the unstructured query and retrieve the embedding vectors that are 'most similar' to the embedded query. A vector store takes care of storing embedded data and performing vector search for us. Supported vector stores are [34]:

- Chroma
- Pinecone
- FAISS
- Lance

We will use **Hugging Face Hub** in order to be able to download pre-trained LLMs. The Hugging Face Hub is a platform with thousands of machine learning models, datasets, and demo apps, all open source and publicly available, in an online platform where people can easily collaborate and build Machine Learning solutions. The Hub works as a central place where anyone can explore, experiment, collaborate, and build technology with Machine Learning [35]

From the supported LangChain LLM providers we will mostly use the **Llama.cpp** provider. The main goal of llama.cpp is to enable LLM inference with minimal setup and state-of-the-art performance on a wide variety of hardware - locally and in the cloud. Some characteristics of this library are the following [36]

- Plain C/C++ implementation without any dependencies
- Apple silicon is a first-class citizen - optimized via ARM NEON, Accelerate and Metal frameworks
- AVX, AVX2 and AVX512 support for x86 architectures 1.5-bit, 2-bit, 3-bit, 4-bit, 5-bit, 6-bit, and 8-bit integer quantization for faster inference and reduced

- memory use Custom CUDA kernels for running LLMs on NVIDIA GPUs (support for AMD GPUs via HIP) Vulkan and SYCL backend support CPU+GPU hybrid inference to partially accelerate models larger than the total VRAM capacity

LLama.cpp uses ggml, a tensor library for machine learning [37]. So llama.cpp can be used with any LLMs which have been converted to ggml or gguf quantized formats, which we discussed in Section 1.1.3.

In order to create a graph of our own machine learning model performance we will use **matplotlib**. Matplotlib is a comprehensive library for creating static, animated, and interactive visualizations in Python. Matplotlib produces publication-quality figures in a variety of hardcopy formats and interactive environments across platforms. Matplotlib can be used in Python scripts, Python/IPython shells, web application servers, and various graphical user interface toolkits. [38]

We will use **unstructured** library in order to be able to read various documents. The unstructured library provides open-source components for ingesting and pre-processing images and text documents, such as PDFs, HTML, Word docs, and many more. The use cases of unstructured revolve around streamlining and optimizing the data processing workflow for LLMs. unstructured modular functions and connectors form a cohesive system that simplifies data ingestion and pre-processing, making it adaptable to different platforms and efficient in transforming unstructured data into structured outputs. [39]

We will depend on **FAISS** library to provide us a vector store implementation and search algorithm to use with LangChain. Faiss is a library for efficient similarity search and clustering of dense vectors. It contains algorithms that search in sets of vectors of any size, up to ones that possibly do not fit in RAM. It also contains supporting code for evaluation and parameter tuning. Faiss is written in C++ with complete wrappers for Python/numpy. Some of the most useful algorithms are implemented on the GPU. [40]

2.4. Rust Libraries

We will talk about the most important Rust libraries that we use for our application and their important parts that we utilize.

In order to create a command line application (cli) we will use **clap** library. Clap is a command line argument parser for Rust. It allows us to create our command-line parser, with all of the bells and whistles, declaratively or procedurally. [41]

To use asynchronous programming in Rust we need an asynchronous runtime, so we will use the most popular one **tokio**. Tokio is an event-driven, non-blocking I/O platform for writing asynchronous applications with the Rust programming language. At a high level, it provides a few major components: [42]

- A multithreaded, work-stealing based task scheduler.
- A reactor backed by the operating system's event queue (epoll, kqueue, IOCP, etc...).
- Asynchronous TCP and UDP sockets.

Tokio provides a runtime for writing reliable, asynchronous, and slim applications with the Rust programming language. It is: [42]

- Fast: Tokio's zero-cost abstractions give us bare-metal performance.
- Reliable: Tokio leverages Rust's ownership, type system, and concurrency model to reduce bugs and ensure thread safety.
- Scalable: Tokio has a minimal footprint, and handles backpressure and cancellation naturally.

We will use **axum** library to develop our web server. Axum is a web application framework that focuses on ergonomics and modularity. Some high level features are: [43]

- Route requests to handlers with a macro free API.
- Declaratively parse requests using extractors.
- Simple and predictable error handling model.
- Generate responses with minimal boilerplate.
- Take full advantage of the tower and tower-http ecosystem of middleware, services, and utilities.

We will use **SeaORM** library so that our backend fetches and writes data in a database. SeaORM is a relational ORM which helps us build web services in Rust with the familiarity of dynamic languages. Some SeaORM features are: [44]

- Async: Relying on SQLx, SeaORM is a new library with async support from day 1.
- Dynamic: Built upon SeaQuery, SeaORM allows us to build complex dynamic queries.
- Testable: Use mock connections and/or SQLite to write tests for our application logic.
- Service Oriented: Quickly build services that join, filter, sort and paginate data in REST, GraphQL and gRPC APIs.

SeaORM supports connections with MySQL, Postgres or SQLite databases [45].

2.5. HTML, CSS, SPA, Typescript, Vue.js

We will use Web Technologies in order to create a Frontend for our application. In this section we will describe the main technologies for our frontend.

HyperText Markup Language (HTML) is the most basic building block of the Web. It defines the meaning and structure of web content. Other technologies besides HTML are generally used to describe a web page's appearance/presentation (CSS) or functionality/behavior (JavaScript). "Hypertext" refers to links that connect web pages to one another, either within a single website or between websites. Links are a fundamental aspect of the Web. By uploading content to the Internet and linking it to pages created by other people, we become an active participant in the World Wide Web. HTML uses "markup" to annotate text, images, and other content for display in a Web browser. HTML markup includes special "elements" such as <head>, <title>, <body> and many others. An HTML element is set off from other text in a document by "tags", which consist of the element name surrounded by "<" and ">". The name of an element inside a tag is case-insensitive. That is, it can be written in uppercase, lowercase, or a mixture. [46]

Cascading Style Sheets (CSS) is a stylesheet language used to describe the presentation of a document written in HTML or XML (including XML dialects such as SVG, MathML or XHTML). CSS describes how elements should be rendered on screen, on paper, in speech, or on other media. CSS is among the core languages of the open web and is standardized across Web browsers according to W3C specifications. Previously, the development of various parts of CSS specification was done synchronously, which allowed the versioning of the latest recommendations, like CSS1, CSS2.1, etc. There will never be a CSS3 or a CSS4; rather, everything is now just "CSS" with individual CSS modules having version numbers. [47]

JavaScript (JS) is a lightweight interpreted (or just-in-time compiled) programming language with first-class functions. While it is most well-known as the scripting language for Web pages, many non-browser environments also use it, such as Node.js, Apache CouchDB and Adobe Acrobat. JavaScript is a prototype-based, multi-paradigm, single-threaded, dynamic language, supporting object-oriented, imperative, and declarative (e.g. functional programming) styles.

JavaScript's dynamic capabilities include runtime object construction, variable parameter lists, function variables, dynamic script creation (via `eval`), object introspection (via `for...in` and Object utilities), and source-code recovery (JavaScript functions store their source text and can be retrieved through `toString()`). The standards for JavaScript are the ECMAScript Language Specification (ECMA-262) and the ECMAScript Internationalization API specification (ECMA-402). [48]

TypeScript (TS) is a programming language that adds static type checking to JavaScript. TypeScript is a superset of JavaScript, meaning that everything available in JavaScript is also available in TypeScript, and that every JavaScript program is a syntactically legal TypeScript program. Also, the runtime behavior of TypeScript and JavaScript is identical. However, TypeScript adds compile time type checking, implementing rules about how different types can be used and combined. This catches a wide variety of programming errors that in JavaScript are only encountered at runtime. Some typing rules are inferred from JavaScript. TypeScript also enables the programmer to annotate their code, to indicate, for example, the types of parameters to a function or the properties of an object. After compilation, type annotations are removed, making the compiled output just JavaScript, meaning it can be executed in any JavaScript runtime. [49]

An **SPA** (Single-page application) is a web app implementation that loads only a single web document, and then updates the body content of that single document via JavaScript APIs such as `Fetch` when different content is to be shown. This therefore allows users to use websites without loading whole new pages from the server, which can result in performance gains and a more dynamic experience, with some trade-off disadvantages such as SEO, more effort required to maintain state, implement navigation, and do meaningful performance monitoring. [50]

Our frontend will utilize all the technologies described above and it will use the **Vue.js** framework. Vue is a JavaScript framework for building user interfaces. It builds on top of standard HTML, CSS, and JavaScript and provides a declarative, component-based programming model that helps us efficiently develop user interfaces of any complexity. The two core features of Vue are:

- **Declarative Rendering:** Vue extends standard HTML with a template syntax that allows us to declaratively describe HTML output based on JavaScript state.
- **Reactivity:** Vue automatically tracks JavaScript state changes and efficiently updates the DOM when changes happen.

Vue can be used in different ways:

- Enhancing static HTML without a build step
- Embedding as Web Components on any page
- Single-Page Application (SPA)
- Fullstack / Server-Side Rendering (SSR)
- Jamstack / Static Site Generation (SSG)
- Targeting desktop, mobile, WebGL, and even the terminal

[51]

2.6. Containers, Docker and Kubernetes

We already talked about the programming languages and the most important programming libraries which we will use for developing our application. In this section we will talk about the most important technologies which we will use in order to deploy and deliver our application.

Containers are executable units of software that package application code along with its libraries and dependencies. They allow the same code to run in many different computing environments, like desktops, servers, IT or cloud infrastructure. Containers take advantage of a form of operating system (OS) virtualization in which features of the OS kernel (like for example, Linux namespaces and cgroups) can be used to isolate processes and control the amount of CPU, memory and disk that those processes can access. More portable and resource-efficient than virtual machines (VMs), containers have become the de facto compute units of modern cloud-native applications. Additionally, containers are critical to the underlying IT infrastructure that powers hybrid multicloud settings—the combination of on-premises, private cloud, public cloud and more than one cloud service from more than one cloud vendor. One way to better understand a container is to examine how it differs from a traditional virtual machine (VM), which is a virtual representation or emulation of a physical computer. A VM is often referred to as a guest, while the physical machine it runs on is called the host. Virtualization technology makes VMs possible. A small software layer which is called a hypervisor, allocates physical computing resources (for example, processors, memory, storage) to each VM. It keeps each VM separate from others so they don't interfere with each other. Each VM then contains a guest OS and a virtual copy of the hardware that the OS requires to run, along with an application and its associated libraries and dependencies. VMware was one of the first to develop and commercialize virtualization technology based on hypervisors. Instead of virtualizing the underlying hardware, container technology virtualizes the operating system (typically Linux) so each container contains only the application and its libraries, configuration files and dependencies. Containers are much more lightweight, faster and more portable than VMs, due to the absence of the guest OS. Containers and virtual machines are not mutually exclusive. For instance, an organization might leverage both technologies by running containers in VMs to increase isolation and security and leverage already installed tools for automation, backup and monitoring [52]. Here are the top advantages of using containers:

- **Lightweight:** Containers eliminate the need for a full OS instance per application and make container files small and easy on resources, by sharing the machine OS kernel. A container's smaller size, especially compared to a VM, means it can spin up quickly and better support cloud-native applications that scale horizontally.
- **Portable and platform-independent:** Containers carry all their dependencies with them, meaning that software can be written once and then run without needing to be re-configured across computing environments (for example, laptops, cloud and on-premises).
- **Supportive of modern development and architecture:** Due to a combination of their deployment portability and consistency across platforms and their small size, containers are an ideal fit for modern development and application patterns—such as DevOps, serverless and microservices—that are built by using regular code deployments in small increments.
- **Improved utilization:** Like VMs, containers enable developers and operators to improve CPU and memory utilization of physical machines. Containers go even further because they enable microservices architecture so that application components can be deployed and scaled more granularly. This is an attractive alternative to scaling up an entire monolithic application because a single component is struggling with its load.
- **Faster time to market:** Containers rely less on system resources, making them faster to manage and deploy than VMs. This feature helps save money and time on application deployment and optimizes time to market.

[52]

The most popular containerization technology nowadays is **Docker**. Docker enables developers to build, deploy, run, update and manage containers. Docker uses the Linux kernel (the operating system's base component) and kernel features (like Cgroups and namespaces) to separate processes so they can run independently. Docker essentially takes an application and its dependencies and turns them into a virtual container that can run on any Windows, macOS or Linux-running computer system. Docker is based on a client-server architecture, with Docker Engine serving as the underlying technology. Docker provides an image-based deployment model, making sharing apps simple across computing environments [52]. Docker is an open platform for developing, shipping, and running applications. Docker allows us to separate our applications from our infrastructure so we can deliver software quickly. With Docker, we can manage our infrastructure in the same ways we manage our applications. By taking advantage of Docker's methodologies for shipping, testing, and deploying code quickly, we can significantly reduce the delay between writing code and running it in production [53]. Docker provides many tools and components, the most important of which is **Docker Engine**. Docker Engine is an open source containerization technology for building and containerizing our applications. Docker Engine acts as a client-server application with: A server with a long-running daemon process `dockerd`. APIs which specify interfaces that programs can use to talk to and instruct the Docker daemon. A command line interface (CLI) client `docker`. The CLI uses Docker APIs to control or interact with the Docker daemon through scripting or direct CLI commands. Many other Docker applications use the underlying API and CLI. The daemon creates and manages Docker objects, such as images, containers, networks, and volumes. [54] **Docker Build** is one of Docker Engine's most used features. Whenever we are creating an image we are using Docker Build. Build is a key part of our software development life cycle allowing us to package and bundle our code and ship it anywhere. Docker Build is more than a command for building images, and it's not only about packaging our code. It's a whole ecosystem of tools and features that support not only common workflow tasks but also provides support for more complex and advanced scenarios [55]. Finally, when we talk about docker is essential to talk about **Docker Compose** too. Docker Compose is a tool for defining and running multi-container applications. It is the key to unlocking a streamlined and efficient development and deployment experience. Compose simplifies the control of our entire application stack, making it easy to manage services, networks, and volumes in a single, comprehensible YAML configuration file. Then, with a single command, we create and start all the services from our configuration file. Compose works in all environments; production, staging, development, testing, as well as CI workflows. It also has commands for managing the whole lifecycle of our application:

- Start, stop, and rebuild services
- View the status of running services
- Stream the log output of running services
- Run a one-off command on a service

[56]

Since we talked about the fundamental concepts of containers and docker, which enables to build and run containers easily, it's time to talk about a more advanced containerization technology used for more complicated production systems which usually run multiple containers, this is **Kubernetes**. Kubernetes, also known as K8s, is an open source system for automating deployment, scaling, and management of containerized applications. It groups containers that make up an application into logical units for easy management and discovery. Kubernetes builds upon 15 years of experience of running production workloads at Google, combined with best-of-breed ideas and practices from the community [57]. Kubernetes is a portable, extensible,

open source platform for managing containerized workloads and services, that facilitates both declarative configuration and automation. It has a large, rapidly growing ecosystem. Kubernetes services, support, and tools are widely available. Containers are a good way to bundle and run our applications. In a production environment, our need to manage the containers that run the applications and ensure that there is no downtime. For example, if a container goes down, another container needs to start. Kubernetes provides us with a framework to run distributed systems resiliently. It takes care of scaling and failover for our application, provides deployment patterns, and more. For example: Kubernetes can easily manage a canary deployment for our system [58]. Some features of kubernetes are:

- Service discovery and load balancing: Kubernetes can expose a container using the DNS name or using their own IP address. If traffic to a container is high, Kubernetes is able to load balance and distribute the network traffic so that the deployment is stable.
- Storage orchestration: Kubernetes allows us to automatically mount a storage system of our choice, such as local storages, public cloud providers, and more.
- Automated rollouts and rollbacks: We can describe the desired state for our deployed containers using Kubernetes, and it can change the actual state to the desired state at a controlled rate. For example, we can automate Kubernetes to create new containers for our deployment, remove existing containers and adopt all their resources to the new container.
- Automatic bin packing: We provide Kubernetes with a cluster of nodes that it can use to run containerized tasks. We tell Kubernetes how much CPU and memory (RAM) each container needs. Kubernetes can fit containers onto our nodes to make the best use of our resources.
- Self-healing: Kubernetes restarts containers that fail, replaces containers, kills containers that don't respond to our user-defined health check, and doesn't advertise them to clients until they are ready to serve.
- Secret and configuration management: Kubernetes lets us store and manage sensitive information, such as passwords, OAuth tokens, and SSH keys. We can deploy and update secrets and application configuration without rebuilding our container images, and without exposing secrets in our stack configuration.
- Batch execution: In addition to services, Kubernetes can manage our batch and CI workloads, replacing containers that fail, if desired.
- Horizontal scaling: Scale our application up and down with a simple command, with a UI, or automatically based on CPU usage.
- IPv4/IPv6 dual-stack: Allocation of IPv4 and IPv6 addresses to Pods and Services Designed for extensibility Add features to our Kubernetes cluster without changing upstream source code.

[58]

3. Specific Knowledge Assistance Approaches

As we have already described, the goal of this thesis is to create a system that helps its users to find and search existing knowledge. We need to specify with more details our problem domain in order to describe the approaches we will use. There is a single common source of documents for all users. These documents can be of various formats like text, markdown, pdf, html or xml files and we will refer to them as “raw input”. The users should be able to prompt the system by asking questions relative to these documents. The system should be able to provide the users the relative information, by using artificial intelligence technologies.

We will approach the problem with two different methods. For the first method we will create a custom text generation model from scratch. We will train this model with the “raw input” data and so it should be able to generate text according to user prompting. For the first method we will take some existing pre-trained text generation models. These models we will be able to answer multiple questions according to their training. However, we will use the RAG technique, which we have described in Section 1.1.4, and we will try to both expand its knowledge with the “raw input” data and at the same to limit its knowledge only to these “raw input” data.

3.1. Custom Text Generation Model Method

In this section we will describe the custom text generation model method in more depth. We will analyze the important steps for our solution and show the most important code snippets of our implementation. Then we list the advantages and disadvantages of this method.

3.1.1. Method Description

The first step is to read the “raw input” data. For this task we will use the python modules `langchain_community.document_loaders` (uses the unstructured library underneath for which we have talked about at Section 2.3) in order to read various documents of different, which exist in a given path `data_path`

```
def read_docs(data_path: str) -> list[Document]:
    txt_loader = DirectoryLoader(data_path, glob="**/*.txt", loader_cls=TextLoader,
    silent_errors=True, show_progress=True, use_multithreading=True)
    txt_docs = txt_loader.load()
    md_loader = DirectoryLoader(data_path, glob="**/*.md", loader_cls=TextLoader,
    silent_errors=True, show_progress=True, use_multithreading=True)
    md_docs = md_loader.load()
    pdf_loader = DirectoryLoader(data_path, glob="**/
*.pdf", loader_cls=UnstructuredPDFLoader, silent_errors=True, show_progress=True,
use_multithreading=True)
    pdf_docs = pdf_loader.load()
    html_loader = DirectoryLoader(data_path, glob="**/
*.html", loader_cls=UnstructuredHTMLLoader, silent_errors=True, show_progress=True,
use_multithreading=True)
    html_docs = html_loader.load()
    xml_loader = DirectoryLoader(data_path, glob="**/
*.xml", loader_cls=UnstructuredXMLLoader, silent_errors=True, show_progress=True,
use_multithreading=True)
    xml_docs = xml_loader.load()
```

```
docs = txt_docs + md_docs + pdf_docs + html_docs + xml_docs
return docs
```

After we have read all the documents, we concatenate them to a single string source. We then create our vocabulary by splitting the string source into unique words using the `word_tokenize` function of module `nltk.tokenize` (from library NLTK for which we talked about at Section 2.3). We add a special EOS (End Of Sentence) token to this vocabulary. We sort the vocabulary tokens (words) and we create the encoded vocabulary by simply assigning values for first token to 0, second token to 1, third token to 2, etc.

Then we split the whole string source in sentences using the `sent_tokenize` function of module `nltk.tokenize`. We split each sentence into words using `word_tokenize` and after the end of each sentence we append the EOS token. So we have now transformed the source string into the tokens (words including EOS token). We now create the encoded tokens by using the mapping from the encoded vocabulary we created from the previous step. So we now have a list with the encoded tokens of the whole source string.

We now create our Xtrain tensor, by using a window of 100 (configurable) encoded tokens. So each row of Xtrain tensor has 100 tokens, and every next row starts from the next token from the start of this row. So first Xtrain row includes token 1 to token 100, second row includes token 2 to token 101, third row includes token 3 to token 103 etc. For each row of Xtrain tensor we add a row at Ytrain tensor with the next token after the last of the row. So first row of Ytrain has token 101, second row of Ytrain has token 102, third row of Ytrain has token 103, etc. With these Xtrain and Ytrain tensors, we will train our model. We select some random sentences and follow the same procedure in order to create Xtest and Ytest tensors for evaluation of our model. It is important to mention that Xtrain and Ytrain are created with all the sentences since we don't want to lose any information of the users' documents, so Xtest and Ytest will not be a very good evaluation since the model will have already see these sentences during its training, maybe in different order. However, this will enable us to be able to determine the performance of our model.

Using PyTorch library (which we talked about at Section 2.3) we create a machine learning model. This first layer of the model is an Embedding layer. The Embedding layer is used to store word embeddings and retrieve them using indices. The input to the module is a list of indices, and the output is the corresponding word embeddings [59]. So the embedding layer will help give some meaning to our naive encoding of the tokens. The second layer of the model is an LSTM layer. The LSTM layer is really good at predicting sequential data, so it will enable us to predict the next token given the 100 sized window of tokens. Then we add a Dropout layer in order to improve model's performance. The last layer is simply a Linear layer which will have output equal to the number of our unique vocabulary tokens. Here is the basic code of our model definition:

```
class Skalm(nn.Module):
    def __init__(self, skalm_props: SkalmProps, n_vocab: int):
        super(Skalm, self).__init__()
        self.embedding = nn.Embedding(
            num_embeddings=n_vocab,
            embedding_dim=skalm_props.embedding_dim,
            padding_idx=0
        )
        self.lstm = nn.LSTM(input_size=skalm_props.embedding_dim,
                            hidden_size=skalm_props.lstm_hidden_size,
                            num_layers=skalm_props.lstm_num_layers,
                            batch_first=True)
```

```

self.dropout = nn.Dropout(ska1m_props.dropout)
self.linear = nn.Linear(ska1m_props.lstm_hidden_size, n_vocab)

def forward(self, x):
    # embedding
    x = self.embedding(x)
    # lstm
    x, _ = self.lstm(x)
    # dropout
    x = self.dropout(x)
    # take only the last output
    x = x[:, -1, :]
    # produce output
    x = self.linear(x)
    return x

```

We now create a training loop in order to train our model using `dataset_train` created by `Xtrain` and `Ytrain` tensors. We are using the Adam optimizer. Adam is an algorithm for first-order gradient-based optimization of stochastic objective functions, based on adaptive estimates of lower-order moments [60]. We use the `CrossEntropyLoss` as our loss function. `CrossEntropyLoss` criterion computes the cross entropy loss between input logits and target and it is useful when training a classification problem with `C` classes [61]. In our case the number of classes is the number of our unique vocabulary tokens. Using the `argmax` function we are able to get the token with highest probability to be the next token. In each train epoch we calculate the loss and the accuracy of the model. After each training epoch, we evaluate the model with the `dataset_test` created by `Xtest` and `Ytest` tensors. During the training we save each model with less loss than our current best model for comparison purposes and finally we keep the model with the least loss as our final model.

```

def train_one_epoch(model: Skalm, loader: DataLoader, optimizer: optim.Adam, loss_fn:
nn.CrossEntropyLoss) -> tuple[float, float]:
    train_epoch_total_loss = 0
    train_epoch_total_correct = 0
    for X_batch, y_batch in loader:
        # Zero your gradients for every batch!
        optimizer.zero_grad()
        # Make predictions for this batch
        y_pred = model(X_batch)
        # Compute the loss and its gradients
        loss = loss_fn(y_pred, y_batch)
        loss.backward()
        # Adjust learning weights
        optimizer.step()
        # calculate
        train_epoch_total_loss += loss.item()
        winners = y_pred.argmax(dim=1)
        train_epoch_total_correct += (y_batch == winners).sum().item() / len(y_batch)

    train_epoch_loss = train_epoch_total_loss / len(loader)
    train_epoch_accuracy = train_epoch_total_correct / len(loader)
    return train_epoch_loss, train_epoch_accuracy

```

```

def validate_one_epoch(model: Skalm, loader_test: DataLoader, loss_fn:
nn.CrossEntropyLoss):
    test_epoch_total_loss = 0
    test_epoch_total_correct = 0
    for X_batch, y_batch in loader_test:
        y_pred = model(X_batch)
        test_loss = loss_fn(y_pred, y_batch)
        test_epoch_total_loss += test_loss.item()
        winners = y_pred.argmax(dim=1)
        test_epoch_total_correct += (y_batch == winners).sum().item() / len(y_batch)

    test_epoch_loss = test_epoch_total_loss / len(loader_test)
    test_epoch_accuracy = test_epoch_total_correct / len(loader_test)
    return test_epoch_loss, test_epoch_accuracy

def train_skallm_lstm(model: Skalm, skalm_config: SkalmConfig, skalm_dir_path: str,
Xtrain: Tensor, Ytrain: Tensor, Xtest: Tensor, Ytest: Tensor) -> tuple[dict[str, Any] |
None, list[float], list[float]]:
    n_epochs = skalm_config.n_epochs
    batch_size = skalm_config.batch_size
    optimizer = optim.Adam(model.parameters(), lr=skalm_config.lr)
    loss_fn = nn.CrossEntropyLoss(reduction="mean")
    dataset_train = TensorDataset(Xtrain, Ytrain)
    dataset_test = TensorDataset(Xtest, Ytest)
    loader_train = DataLoader(dataset_train, shuffle=True, batch_size=batch_size)
    loader_test = DataLoader(dataset_test, shuffle=True, batch_size=batch_size)
    best_model_state_dict = None
    best_loss = np.inf
    train_losses: list[float] = []
    train_accuracy_list: list[float] = []
    test_losses: list[float] = []
    test_accuracy_list: list[float] = []
    for epoch in range(n_epochs):
        model.train(True)
        train_epoch_loss, train_epoch_accuracy = train_one_epoch(model, loader_train,
optimizer, loss_fn)
        train_losses.append(train_epoch_loss)
        train_accuracy_list.append(train_epoch_accuracy)
        # Validation
        model.eval()
        with torch.no_grad():
            test_epoch_loss, test_epoch_accuracy = validate_one_epoch(model, loader_test,
loss_fn)
            test_losses.append(test_epoch_loss)
            test_accuracy_list.append(test_epoch_accuracy)
            if test_epoch_loss <= best_loss:
                best_loss = test_epoch_loss
                best_model_state_dict = model.state_dict()
                save_model(skalm_dir_path, best_model_state_dict, train_losses,
train_accuracy_list, test_losses, test_accuracy_list, epoch)

```

```

save_model(skalm_dir_path, best_model_state_dict, train_losses, train_accuracy_list,
test_losses, test_accuracy_list, None)
return best_model_state_dict, train_losses, test_losses

```

We perform the training only on CPU due to the hardware restrictions of our laptop (“HP Laptop 15s-eq2xxx” with processor “AMD Ryzen 5 5500U”) for 5 days using only one book as a user document [62]. We show the evaluation results:

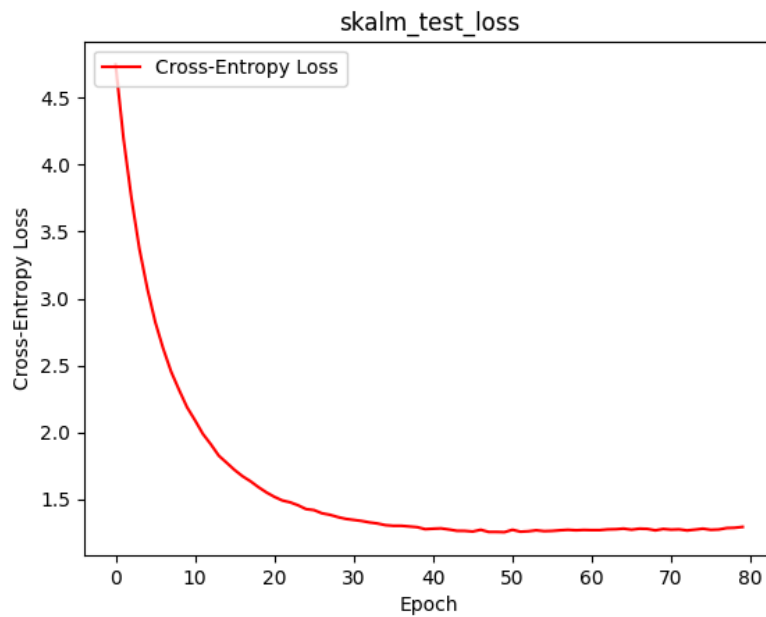

IMAGE 4: SkaLM Test Loss

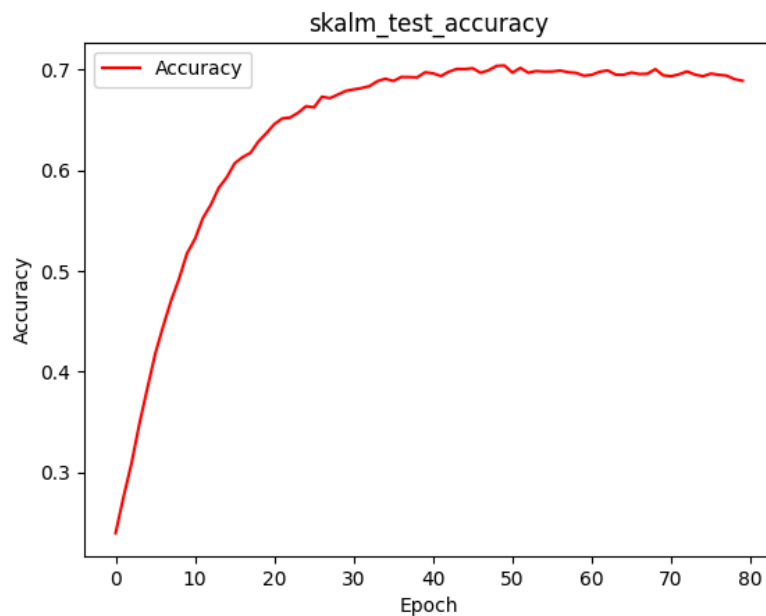

IMAGE 5: SkaLM Test Accuracy

When users prompt the system with this model then we split the question to sentences and then to encoded tokens maximum of 100 (same as the window we used for training) tokens. If the

question is less than 100, then we add a special padding token to the left as many times as needed in order to reach 100 tokens. The system invokes the model in order to predict the next word. The system then shifts the question to the left, replaces the last token with the predicted one and then invokes the model again until it reaches a maximum of generated tokens (default 160) or a maximum of EOS tokens (default 6).

3.1.2. Method Advantages and Disadvantages

We described the process of the method. This method offers very little advantages and is not very suitable for a complete fully functional solution.

Advantages of this method are:

- Independence: Does not rely in any pre-trained text generation models.
- Flexibility: The model creation and training is fully customizable and can be changed to better suit the knowledge field for which the assistant is needed.

Disadvantages of this method are:

- Needs many sources: The model needs to learn both the language and the knowledge field from the documents, so it needs thousands of documents in order to be able to perform somewhat well.
- Highly consuming: Each time a document is added, removed or edited the model needs to be retrained, which is a very time and resource consuming task.
- Hard to implement: This method needs a dedicated data science team to fine tune and improve the model parameters and layers, in order to be able to achieve a satisfying result for a specific knowledge field.
- Hard to return sources: It's really hard, almost impossible, to return the sources of the relative information with which the answer was constructed.

3.2. Retrieval Augmented Generation (RAG) Method

In this section we will describe the Retrieval Augmented Generation (RAG) method in more depth. We will analyze the important steps for our solution and show the most important code snippets of our implementation. Then we list the advantages and disadvantages of this method.

3.2.1. Method Description

For the RAG method we will depend on existing pre-trained LLMs. We have described the characteristics of LLMs at Section 1.1.3.

The first step is to read the “raw input” data from the users’ documents similar to what we did in the previous method. We will use the same `read_docs` python function we showed before.

We will use class `RecursiveCharacterTextSplitter` from module `langchain.text_splitter` in order to split the “raw input” in to chunks:

```
docs = read_docs(data_path)
# transformation: split the documents into chunks
splitter = RecursiveCharacterTextSplitter(
    chunk_size=128,
    chunk_overlap=8
```

```
)
texts = splitter.split_documents(docs)
```

Then we need an embedding model. Embeddings create a vector representation of a piece of text. This is useful because it means we can think about text in the vector space, and do things like semantic search where we look for pieces of text that are most similar in the vector space [63]. We will use the all-MiniLM-L6-v2 pre-trained model from hugging face, which maps sentences & paragraphs to a 384 dimensional dense vector space and can be used for tasks like clustering or semantic search. [64]. Then we will use the FAISS vector store (which we described in Section 2.3) in order to save the embedding documents as a vector store to a local path.

```
embeddings = HuggingFaceEmbeddings(
    model_name=embedding_model_path,
    model_kwargs={'device': 'cpu'},
    encode_kwargs = {'normalize_embeddings': True}
)
db = FAISS.from_documents(texts, embeddings)
db.save_local(vector_store_path, constants.VS_INDEX_NAME)
```

Now when users are prompting the system we create LangChain chain as of official documentation [65]. For this we create a pipeline of an existing pre-trained model. In our custom python function `create_llm` we support two types of pre-trained models. The first one is using llama.cpp library we described in Section 2.3 for models in gguf format (mainly llama2 and llama3). The second type is using `AutoModelForCausalLM` with `HuggingFacePipeline` which supports most text generation models which have been uploaded in hugging face hub together with their configuration. We load the vector store which we stored in the previous steps. We create a more complicated chain in order to be able to return the relevant source together with the answer as per official documentation [66]. The result consists of the question, the answer and the context which is a list with the relevant Documents of the chunks in which the model found the answer. More advanced models like llama2 and llama3 accept system prompting which allows the users to instruct the LLM in which way to construct the final answer.

```
def create_llm(llm_model_path: str, model_type: str, temperature: int, top_p: int):
    context_length = 512
    max_tokens = 160
    batch_size = 512
    last_n_tokens = 8
    repetition_penalty = 1.1
    if model_type == 'llamacpp':
        # Callbacks support token-wise streaming
        callback_manager = CallbackManager([StdOutCallbackHandler()])
        llm = LlamaCpp(
            model_path=llm_model_path,
            temperature=temperature,
            max_tokens=max_tokens,
            last_n_tokens_size=last_n_tokens,
            top_p=top_p,
            callback_manager=callback_manager,
            verbose=True, # Verbose is required to pass to the callback manager
            client=None,
            n_ctx=context_length,
```

```

        n_parts=-1,
        seed=-1,
        f16_kv=True,
        logits_all=False,
        vocab_only=False,
        use_mlock=False,
        n_threads=None,
        n_batch=batch_size,
        n_gpu_layers=None,
        suffix=None,
        logprobs=None,
        repeat_penalty=repetition_penalty
    )
    return llm
elif model_type == 'huggingface':
    tokenizer = AutoTokenizer.from_pretrained(llm_model_path)
    model = AutoModelForCausalLM.from_pretrained(llm_model_path, device_map='cpu')
    pipe = pipeline("text-generation", model=model, tokenizer=tokenizer,
max_length=context_length)
    llm = HuggingFacePipeline(pipeline=pipe)
    return llm
else:
    raise Exception(f"unsupported model_type {model_type}")

def create_chain(vector_store_path: str, embedding_model_path: str, llm_model_path: str,
prompt_template: str, model_type: str, temperature: int, top_p: int):

    # load the language model
    llm = create_llm(llm_model_path, model_type, temperature, top_p)
    # load the interpreted information from the local database
    embeddings = get_embeddings(embedding_model_path)
    db = FAISS.load_local(vector_store_path, embeddings, constants.VS_INDEX_NAME,
allow_dangerous_deserialization=True)
    # prepare a version of the llm pre-loaded with the local content
    retriever = db.as_retriever(search_kwargs={'k': 9})
    prompt = PromptTemplate(
        template=prompt_template,
        input_variables=['context', 'question']
    )

def format_docs(docs):
    return "\n\n".join(doc.page_content for doc in docs)

rag_chain_from_docs = (
    RunnablePassthrough.assign(context=(lambda x: format_docs(x["context"])))
    | prompt
    | llm
    | StrOutputParser()
)

rag_chain_with_source = RunnableParallel(

```



```
    {"context": retriever, "question": RunnablePassthrough()}
  ).assign(answer=rag_chain_from_docs)
  return rag_chain_with_source

qa_chain = create_chain(vector_store_path, embedding_model_path, llm_model_path,
prompt_template, model_type, temperature, top_p)
output = qa_chain.invoke(question)
invoke_output = InvokeOutput.from_output_dict(output)
```

3.2.2. Method Advantages and Disadvantages

We described the process of the RAG method. This method offers many advantages with only a few disadvantages and therefore it is recommended for a complete functional system.

Advantages of this method are:

- Needs only sources relative to knowledge field: The model already understands the needed language, so it needs access only to the relevant documents for our desired knowledge field.
- Adaptable: New, deleted or altered documents demand only the vector store to be recreated, so the system can adapt to changes relatively quickly.
- Easy to implement: This method can be implemented easily with the dependency on the libraries we use without any deep advanced knowledge on how LLMs work.
- Able to return sources: It's really easy to return the relevant sources in which the answer was found.
- Prompting: It's easy to specify system prompting with advanced LLMs that support it, in order to change the style or even the allowed or disallowed content of the answers.

Disadvantages of this method are:

- Dependency on external LLMs: It requires external pre-trained LLMs. While nowadays there are plenty of those and new ones are created almost every year, it is not always clear how they are trained and what biases they have.
- Inflexibility: The model structure and training procedure cannot be altered (sometimes it can be extended with additional sources though).

4. System Architecture

Now that we have explained the two methods on which our solution is based upon, we are ready to describe the system architecture of our complete solution.

4.1. System Components

We have developed 4 basic components for our application. The `ska_llm` component, which contains a library and a command line application, is implemented in python and it is responsible for all document processing and machine learning tasks. The `ska_cli` command line application is implemented in rust and is responsible for various administration tasks and uses the `ska_llm` internally to expose a more friendly command line interface for the machine learning tasks needed to be performed by the admin. The `ska_server` component, implemented in rust as well, exposes a REST API, which enables users to perform the various tasks of the application, like prompting the LLMs. Finally, the `ska_frontend` materializes the Graphical User Interface with which the users can interact with.

Apart from the four components we developed, we utilize three extra components for our complete solution. The first one is Keycloak [67], an open source Identity and Access Management solution which enables our users to login and to be authenticated and authorized to perform specific actions of our application. The second one is PostgreSQL [68], an advanced open source relational database which our application uses for storing and fetching data. The final component is an `api_gateway` which will lay ahead of our services and redirect the web traffic to the needed service for the task.

In the following diagram, we show the fundamental Specific Knowledge Assistant (SKA) System Components. With green color we have marked the components that we develop. With burgundy color we have marked the extra components that we utilize and configure them in order to complete our system.

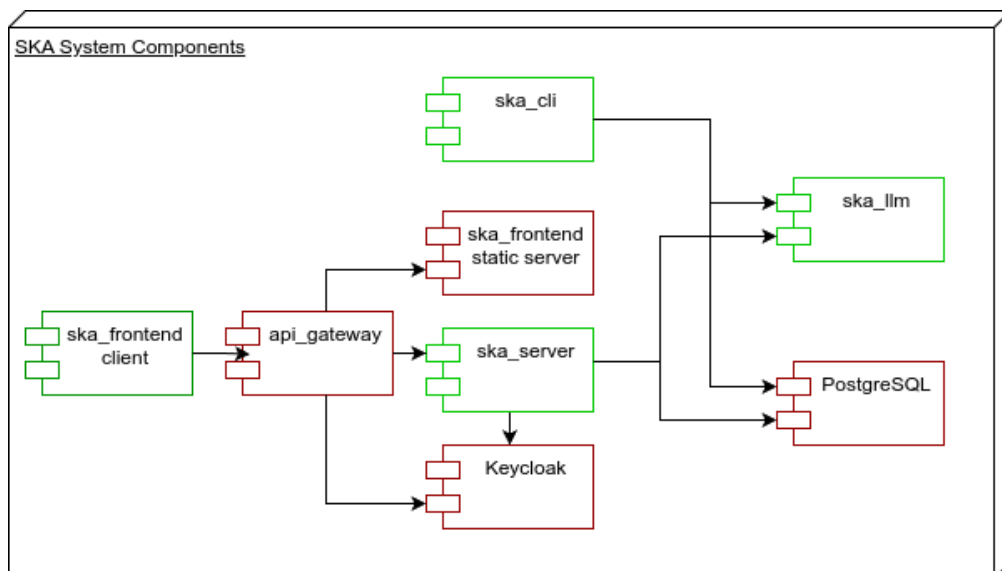

IMAGE 6: SKA System Components

As we already said, the `ska_llm` component is implemented in python and it is responsible for all document processing and machine learning tasks. It supports five crucial for our application

operations which are using the libraries we described in Section 2.3. The operation `download_llm` downloads some given models from hugging face hub [35]. The operation `rag_prepare` performs the preparation for the RAG method that we discussed in Section 3.2.1, including reading users' documents and storing their chunks in vector store. The operation `rag_invoke` invokes the given LLM and answers the given question based on the context of the relevant chunks found in the vector store. The operation `create_llm` creates and trains the SKA text generation model we described in Section 3.1.1. The operation `invoke_skalm` invokes our custom generation model and answers the question with the procedure we described in Section 3.1.1. We show a high level diagram of these basic operations:

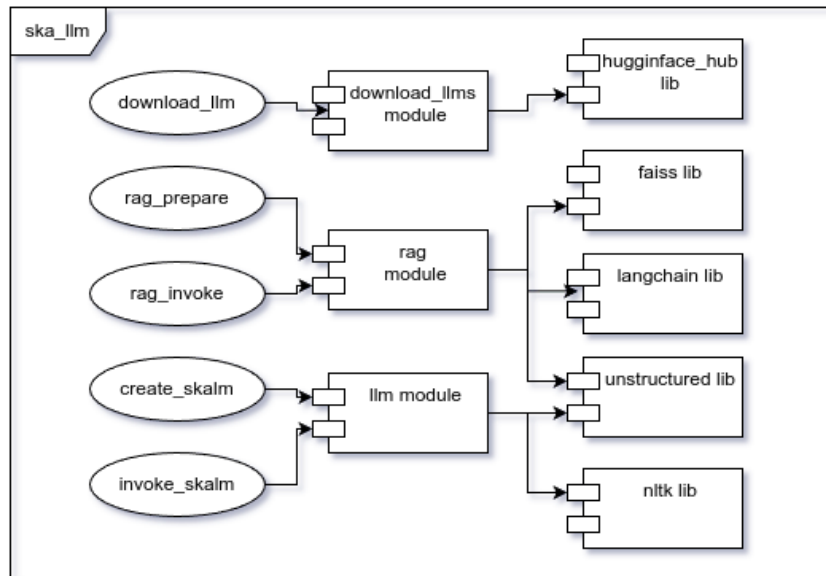

IMAGE 7: SKA LLM operations

We have already said that the `ska_cli` command line application is implemented in rust, it is responsible for various administration tasks and it uses the `ska_llm` internally. This cli component exposes a friendly command line interface so that the admin can perform various operations. For the command line interface and argument parsing we will depend on `clap` library. For all database access we depend on the `SeaORM` library which we have describe in Section 2.4. There are two top level commands, the `command_db` and `command_model`. The first command, `command_db`, is responsible for administration tasks that affect our PostgreSQL database. It has a single child command `command_migrate` which migrates the database schema if there is a new schema version available. The second top level command, `command_model`, is responsible for all the machine learning tasks. We don't use any relevant rust libraries for these tasks, but the core functionality is handled by our `ska_llm` component as we have explained before. It has 5 child commands. The first command `command_download` downloads the needed machine learning models form hugging face hug [35]. The predefined list with supported models currently are:

- `all-MiniLM-L6-v2` [64]: A sentence-transformers model which maps sentences & paragraphs to a 384 dimensional dense vector space. It is used as our embedding model when we are storing/ searching context chunks in/from our vector store.
- `Llama-2-7B-Chat-GGUF` [69]: A Llama-2 model quantized for better invoking times performance, but with less accuracy.
- `Meta-Llama-3-8B-Instruct-GGUF` [70]: A Llama-3 model quantized for better invoking times performance, but with less accuracy.

The second command `command_insert` inserts the models from the temporary downloaded location to a persisted location that can be read by our application. The commands `command_create_skalm` and `command_rag_prepare` are essentially wrappers around the equivalent operations of our `ska_llm` module. They also perform some extra checks and validations to disallow unwanted consequences. The command `command_rag_invoke` performs validations and uses internally either `rag_invoke` or `invoke_skalm` operations of `ska_llm` components depending on the selected model. The following is a high level diagram showing the basic operations of `ska_cli` and the most important modules they are using.

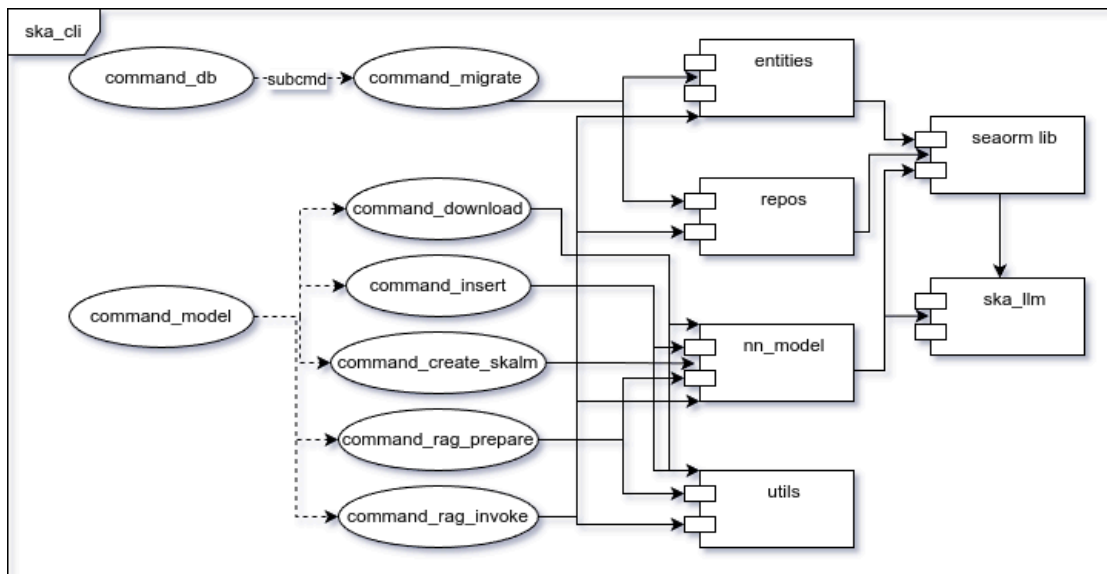

IMAGE 8: SKA CLI operations

The `ska_server` component is implemented in rust, it exposes a REST API with some http endpoints which will be called by the `ska_frontend` component (we will describe in a later paragraph). It uses the same code base as the `ska_cli` component in order to have consistent business logic and be able to share domain relevant modules like `entities` and `repos`. For the http api construction we depend on the `axum` library which we discussed in Section 2.4. All the http endpoints are protected and need an authenticated user with required permissions for allowed access. The authentication is performed by implementing an `auth_middleware` which is used by all endpoints. Each endpoint demands different user roles for a user to have in order to be allowed to access it. There are two top level routes `route_auth` and `route_assistant`. The first route `route_auth` has only one operation `app_login` and is called when users are logged in the app in order to update users' details from the users pool to our database. The second top level endpoint route `route_assistant` enables three basic categories of operations. The first category `fetch` is about fetching user data like chats and historical messages. The second category `chat CRUD` is about CRUD (Create Read Update Delete) operations on user's chats, which allows users to manage their chats. The last operation, `ask question`, is about users asking questions to a selected chat which uses a defined LLM. This operation performs various validations and uses our `ska_llm` component internally as well in order to invoke the required LLM. We show a simple high level diagram of `ska_server` component.

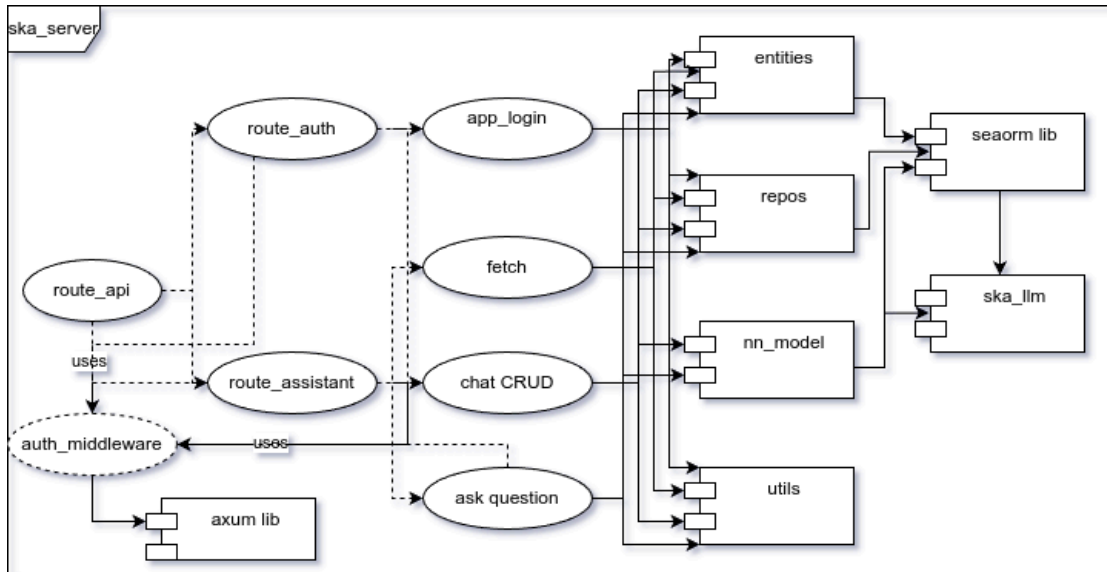

IMAGE 9: SKA Server operations

The `ska_frontend` component materializes the Graphical User Interface with which the users can interact with. It actually consists of two sub components. The first one is `ska_frontend client` which contains all the built and bundled final needed files like html, css, javascript, images, etc. The second sub component `ska_frontend static server` is a simple http server, implemented by using a simply configured nginx instance, which serves all the files needed for the `ska_frontend client` to run in the users' browsers. The `ska_frontend client` is what we call a Single Page Application (SPA) [46] so the pages can contain complex logic in the client side and dynamically change their content without fetching new complete html pages from a server for any single request. The implementation is based on the Vue.js library [51]. The multiple pages can be achieved in the client side by using the `Vue router` library [71]. The client is using the "Asynchronous JavaScript and XML" (AJAX) [72] technique in order to fetch data from our `ska_server` by utilizing the `axios` library [73]. For the authentication and authorization to work, we are using the `oidc-client-ts` library [74] which communicates with the Keycloak instance in order to fetch the needed tokens (we will talk about it with more details when we will describe Keycloak). The client provides three top level pages from which users can perform their operations. The `page_home` is the first page that is shown to a user. It shows a short description about the app and its content changes slightly depending on whether users are logged in or not. The `page_account` enables logged in users to see their account details as well as to edit them. The `page_assistant` is the most important page as it enables logged in users to use the Specific Knowledge Assistant. There users can create, edit or delete a chat with a selected LLM. Users can then ask questions in this chat and fetch historical questions and answers of existing chats. The following diagram shows a high level overviews of `ska_frontend` :

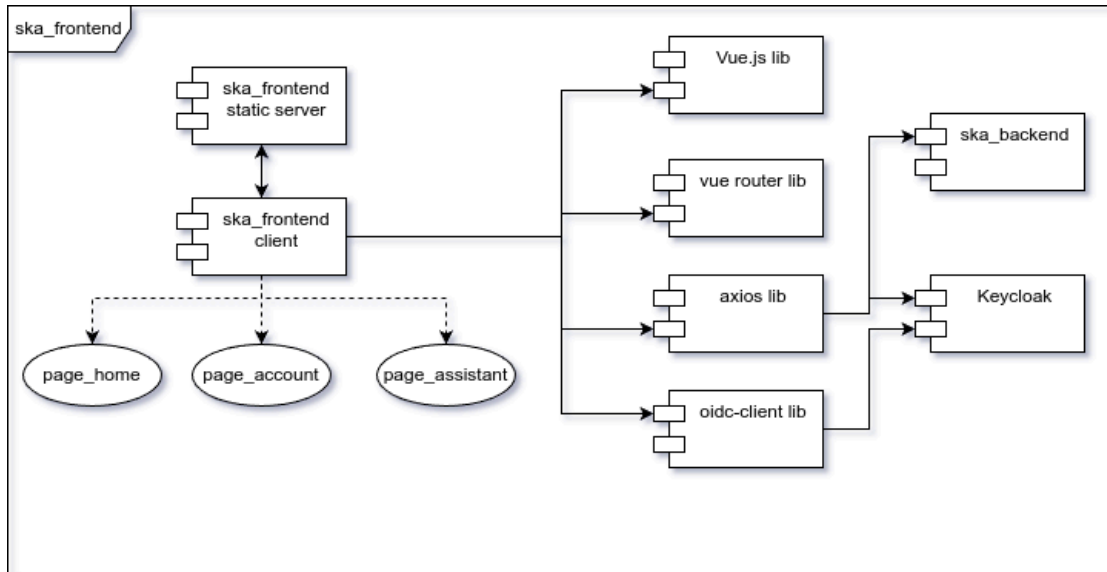

IMAGE 10: SKA Frontend operations

The keycloak component is used as a user pool and as a user authentication and authorization utility. For this we have created a specific SKA Realm which contains the available users together with their assigned roles. The supported roles are:

- SKA_ADMIN: role that practically allows access to all endpoints
- SKA_USER: role that allows users to edit their account info and use the assistant functionality.
- SKA_GUEST: not used in current version but reserved in case of wanted future functionality additions.

In order to authorize and authenticate users in `ska_frontend` and protect our endpoints in `ska_server` components we use the OpenID Connect “Authorization Code flow”, which follows essentially the OAuth2 “Authorization Code flow with PKCE”. The steps that are performed for this authorization flow are the following

- Users clicks “login” in `ska_frontend` .
- `ska_frontend client` using `oidc-client-ts` library creates a cryptographically-random `code_verifier` and from this generates a `code_challenge` and redirects user to Keycloak login page along with the `code_challenge`.
- Keycloak creates a cryptographically-random `code_verifier` and from this generates a `code_challenge`.
- Users authenticate using their credentials.
- Keycloak stores the `code_challenge` and redirects users back to the application with an authorization code, which is good for one use.
- `ska_frontend client` using `oidc-client-ts` sends this code and the `code_verifier` to a keycloak endpoint
- Keycloak verifies the `code_challenge` and `code_verifier` and responds with an ID token and access token, and a refresh token.
- `ska_frontend client` passes the access token to the Authorization header in every request to `ska_server` using `axios` library.

The following example from frameworks.readthedocs.io can clarify the procedure, in which we can replace the “Angular Client” with our `ska_frontend client` component.

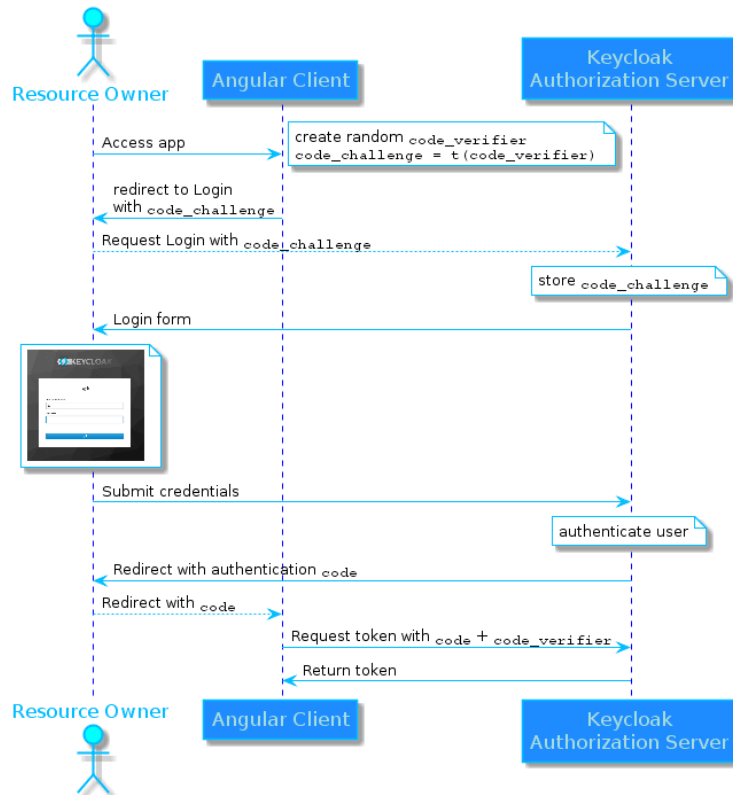

IMAGE 11: Keycloak OAuth2 Authorization Code flow with PKCE [75]

The PostgreSQL database is used in order to persist users' data. Specifically we use the table `users` to store each user who logs in to our application. We update their details in each login. Each user can have multiple chats which we store to table `user_chat`. Each chat can have multiple messages some of them are "ANSWER" type and some of them are "QUESTION" type. We store the messages to table `chat_message`. Here is the Entity Relationship Diagram (ERD) of our database:

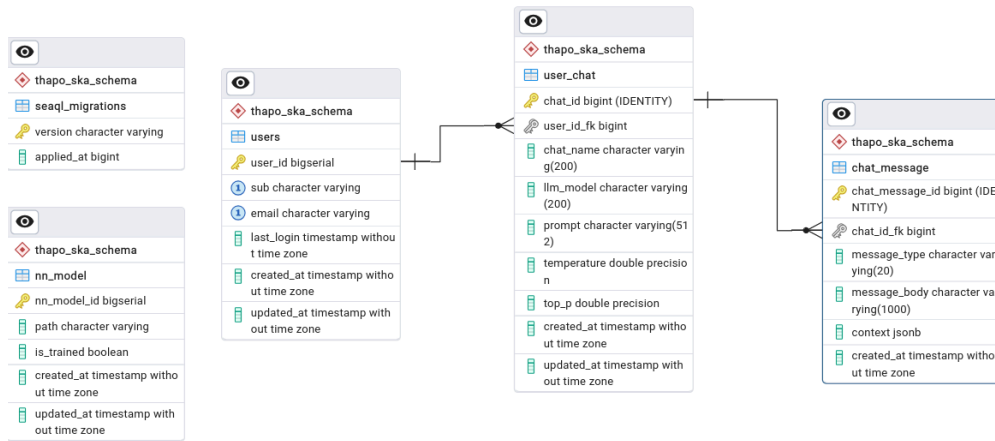

IMAGE 12: SKA Database ERD

The api gateway is implemented by either using a nginx [76] reverse proxy or a kubernetes Ingress [77] depending on the deployment method. All the incoming http requests reach this component at first and then they get redirected to the desired service. This enables us to have a single component which can be configured with rules. Additionally, we have the benefit to serve the whole application under a single owned domain name and redirect the traffic based on http paths. Specifically we configure the following http paths redirections:

- `/app` to `ska_frontend` : any http path that starts with `/app` is redirected to `ska_frontend` service
- `/backend` to `ska_server` : any http path that starts with `/backend` is redirected to `ska_server` service
- `/iam` to Keycloak : any http path that starts with `/iam` is redirected to Keycloak service

4.2. Development Lifecycle and Deployment

We talked about our fundamental System components and modules. Now we will briefly talk about the development lifecycle of the system and its deployment methods.

The code of our application exists in a git repository at <https://github.com/ThanosApostolou/thapo-ska>. There are 3 fundamental branches. New code is directly pushed into `main` branch or merged by some other feature branch into `main` branch. When changes of multiple commits have been tested enough locally, then the `main` branch is merged into `dev` branch. After multiple merges in `dev` branch, when we are ready for a release we merge `dev` branch into `prod` branch.

In alignment with the git branches, the application can run with 3 different environments:

- local environment
- dev environment
- prod environment

Each environment specifies different configuration for our services (e.g. about which url the frontend uses, which url the backend uses, which database schema to use, etc...).

The application is continuously deployed by use CI/CD (Continuous Integration and Continuous Delivery) practices [78]. To achieve this we use Jenkins [79], an open source automation server. In more details:

- `main` : `main` branch is tested only locally, so we don't deploy anything for this.
- `dev` : Whenever changes are merged to `dev` branch, a jenkins pipeline is executed. The basic pipeline tasks are:
 - build all our services as docker images
 - push the built docker images to our private docker repository
 - deploy and start the application with `dev` environment at our private server, using docker compose (see Section 2.6).

The `dev` application is targeting a private port which can be accessed only by our local network or by using vpn. This environment's purpose is to have a fully deployed system for testing purposes which is not affected by local changes.

- `prod` : Whenever changes are merged to `prod` branch, a jenkins pipeline is executed. The basic pipeline tasks are:
 - build all our services as docker images
 - push the built docker images to our private docker repository
 - deploy and start the application with `prod` environment at a k3s [80] kubernetes instance (see Section 2.6) installed in our private server. For easier management of all the kubernetes resources we need to create, we use Helm [81].

The `prod` application is targeting a port which can be accessed publicly from the internet by all the users. Currently the domain our application is using is the <https://thapo-ska.thapo.org/app>, but it is possibly to change after the completion of this thesis.

5. Usage and Execution of the Application

We talked about the System Architecture of our application, now we will show real execution of our application and its results.

5.1. Command Line Interface (CLI) Usage

We will show examples of executing the `ska_cli` component. In some cases we will show the description of the command and in other cases we will show the important parts of the command output, where it makes sense.

Running `app-cli --help` will describe the top level command line arguments and options of the application.

```
Usage: app-cli <COMMAND>

Commands:
  model
  db
  help  Print this message or the help of the given subcommand(s)

Options:
  -h, --help      Print help
  -V, --version   Print version
```

Starting with the `db` top level command, running `app-cli db --help` will describe its arguments and options

```
Usage: app-cli db <COMMAND>

Commands:
  migrate  migrates db
  help     Print this message or the help of the given subcommand(s)

Options:
  -h, --help  Print help
```

We see that it has a single `migrate` subcommand. When we run this command `app-cli db migrate --help`, it shows that it doesn't take any arguments. We use this command in order to migrate our database schema when there are changes.

```
migrates db

Usage: app-cli db migrate

Options:
  -h, --help  Print help
```

To see the arguments and options of the second top level command we run the command `app-cli model --help`. We see that there are five subcommands available: `download`, `insert`, `rag-prepare`, `rag-invoke` and `create-skalm`.

```
Usage: app-cli model <COMMAND>
```

```

Commands:
  download      downloads models and LLMs for RAG
  insert        inserts the downloaded LLMs in the systems files location
  rag-prepare   prepares the documents and vector store for RAG
  rag-invoke    invokes an LLM with a question
  create-skalm  creates and trains SKA text generation model
  help         Print this message or the help of the given subcommand(s)

Options:
  -h, --help  Print help

```

Subcommand `download` downloads the needed models and LLMs use for the RAG method. The models we download are those we described the `ska_cli` component at Section 4

- all-MiniLM-L6-v2 [64]
- Llama-2-7B-Chat-GGUF [69]
- Meta-Llama-3-8B-Instruct-GGUF [70]

```
downloads models and LLMs for RAG
```

```
Usage: app-cli model download
```

```
Options:
  -h, --help  Print help
```

Some partial output running the actual command gives:

```

...

config.json: 100%|████████████████████| 612/612 [00:00<00:00, 5.43MB/s]
config_sentence_transformers.json: 100%|████████████████████| 116/116 [00:00<00:00, 1.02MB/s]
modules.json: 100%|████████████████████| 349/349 [00:00<00:00, 3.79MB/s]
sentence_bert_config.json: 100%|████████████████████| 53.0/53.0 [00:00<00:00, 364kB/s]
tokenizer_config.json: 100%|████████████████████| 350/350 [00:00<00:00, 2.66MB/s]
tokenizer.json: 100%|████████████████████| 466k/466k [00:00<00:00, 1.98MB/s]
vocab.txt: 100%|████████████████████| 232k/232k [00:00<00:00, 917kB/s]
pytorch_model.bin: 100%|████████████████████| 90.9M/90.9M [00:26<00:00, 3.47MB/s]
model.safetensors: 100%|████████████████████| 90.9M/90.9M [00:32<00:00, 2.84MB/s]
Fetching 17 files: 100%|████████████████████| 17/17 [00:34<00:00, 2.00s/it]

...

llama-2-7b-chat.Q2_K.gguf: 100%|████████████████████| 2.83G/2.83G [04:04<00:00, 11.6MB/s]
Fetching 5 files: 100%|████████████████████| 5/5 [04:04<00:00, 48.88s/it]

...

meta-llama-3-8b-instruct.Q2_K.gguf: 100%|████████████████████| 3.18G/3.18G [04:36<00:00, 11.5MB/s]
Fetching 4 files: 100%|████████████████████| 4/4 [04:37<00:00, 69.45s/it]

```

The subcommand `app-cli model insert --help` shows the description of the `insert` subcommand. It doesn't take any arguments. It copies the models, which got downloaded in a

temporary directory with the previous command, to a location which can be read by the system. The need of a separate command instead of downloading the models directly to our system directory is done in order to avoid partially downloaded models as well as for security concerns.

inserts the downloaded LLMs in the systems files location

```
Usage: app-cli model insert
```

```
Options:
```

```
-h, --help Print help
```

The subcommand `rag-prepare` reads the users' documents and creates the vector store so that it can be read by the application later. Running the command `app-cli model rag-prepare --help` shows that the command receives an option about which embedding model to use:

prepares the documents and vector store for RAG

```
Usage: app-cli model rag-prepare --emb-name <EMB_NAME>
```

```
Options:
```

```
-e, --emb-name <EMB_NAME>
-h, --help Print help
```

Running `app-cli model rag-prepare --emb-name all-MiniLM-L6-v2` shows that it found a pdf document (we use a single pdf book [62] as users' source), which it split in chunks with which it created the FAISS vector store (we have described with more details the procedure at Section 3.2.1):

```
DirectoryLoader txt
0it [00:00, ?it/s]
DirectoryLoader md
0it [00:00, ?it/s]
DirectoryLoader pdf
100%|████████████████████| 1/1 [01:03<00:00, 63.77s/it]
DirectoryLoader html
0it [00:00, ?it/s]
DirectoryLoader xml
0it [00:00, ?it/s]
len(docs): 1
splitter.split_documents
get_embeddings()
get_embeddings start
get_embeddings end
FAISS.from_documents
FAISS.save_local
```

The subcommand `create-skalm` creates and trains the SKA custom text generation model as we have discussed at Section 3.1.1. Running the command `app-cli model create-skalm --help` shows that the command receives no arguments. We won't show the output of the full execution since it takes days to complete and it is very long.

creates and trains SKA text generation model

```
Usage: app-cli model create-skalm
```

Options:

```
-h, --help Print help
```

Finally, the subcommand `rag-invoke` invokes the system specifying a desired embedding model, an LLM, a question and an `prompt-template`. The `prompt-template` option is optional and if omitted the default for this LLM will be used. Running the command `app-cli model rag-invoke --help` the output below:

invokes an LLM with a question

```
Usage: app-cli model rag-invoke [OPTIONS] --emb-name <EMB_NAME> --llm-name <LLM_NAME> --question <QUESTION>
```

Options:

```
-e, --emb-name <EMB_NAME>
-l, --llm-name <LLM_NAME>
-q, --question <QUESTION>
-p, --prompt-template <PROMPT_TEMPLATE>
-h, --help Print help
```

Running `app-cli model rag-invoke --emb-name all-MiniLM-L6-v2 --llm-name llama2-7B --question "what is a database?"` we see that the system returns a JSON object with 3 top level keys. The first one is `context` which shows the relevant chunks of the Documents that the LLM found the relevant information. The second one is the `question` that users provided. The third one is the answer of the LLM.

```
{
  "context": [
    {
      "page_content": "Designing Objects for Relational Databases",
      "metadata": {
        "source": ".config/ska/local/data/books/[Eric Evans] (2003) Domain Driven Design Tackling Complexity in the Heart of Software/[Eric Evans] (2003) Domain Driven Design Tackling Complexity in the Heart of Software.pdf"
      }
    },
    {
      "page_content": "systems must use some nonobject technical infrastructure, most commonly relational databases. But making a coherent model that",
      "metadata": {
        "source": ".config/ska/local/data/books/[Eric Evans] (2003) Domain Driven Design Tackling Complexity in the Heart of Software/[Eric Evans] (2003) Domain Driven Design Tackling Complexity in the Heart of Software.pdf"
      }
    },
    {
      "page_content": "But for the important common case of a relational database acting as the persistent form of an object-oriented domain, simple",
      "metadata": {
        "source": ".config/ska/local/data/books/[Eric Evans] (2003) Domain Driven Design Tackling Complexity in the Heart of Software/[Eric Evans] (2003) Domain Driven Design Tackling Complexity in the Heart of Software.pdf"
      }
    }
  ],
  "question": "what is a database?",
  "answer": "A database is a structured collection of data that is organized and stored in a way that allows for efficient retrieval and management. It typically consists of tables, rows, and columns, and is used to store and manage information in a systematic and organized manner."
}
```

```

    }
  },
  {
    "page_content": "the database is used to assemble new objects. Indeed, the
code that usually has to be written makes it hard to forget this",
    "metadata": {
      "source": ".config/ska/local/data/books/[Eric Evans] (2003) Domain Driven
Design Tackling Complexity in the Heart of Software/[Eric Evans] (2003) Domain Driven
Design Tackling Complexity in the Heart of Software.pdf"
    }
  },
  {
    "page_content": "There are three common cases:\n\n1. The database is primarily
a repository for the objects.\n\n121",
    "metadata": {
      "source": ".config/ska/local/data/books/[Eric Evans] (2003) Domain Driven
Design Tackling Complexity in the Heart of Software/[Eric Evans] (2003) Domain Driven
Design Tackling Complexity in the Heart of Software.pdf"
    }
  },
  {
    "page_content": "designing objects for relational databases, 159–
161\n\nencapsulation, 154\n\nexample, 172–173\n\nand FACTORIES, 157–159",
    "metadata": {
      "source": ".config/ska/local/data/books/[Eric Evans] (2003) Domain Driven
Design Tackling Complexity in the Heart of Software/[Eric Evans] (2003) Domain Driven
Design Tackling Complexity in the Heart of Software.pdf"
    }
  },
  {
    "page_content": "There is a raft of techniques for dealing with the technical
challenges of database access. Examples include encapsulating SQL",
    "metadata": {
      "source": ".config/ska/local/data/books/[Eric Evans] (2003) Domain Driven
Design Tackling Complexity in the Heart of Software/[Eric Evans] (2003) Domain Driven
Design Tackling Complexity in the Heart of Software.pdf"
    }
  },
  {
    "page_content": "reality presents the usual problems of a mixture of paradigms
(see Chapter 5). But the database is more intimately related to",
    "metadata": {
      "source": ".config/ska/local/data/books/[Eric Evans] (2003) Domain Driven
Design Tackling Complexity in the Heart of Software/[Eric Evans] (2003) Domain Driven
Design Tackling Complexity in the Heart of Software.pdf"
    }
  },
  {
    "page_content": "mapping between database tables and objects. There are other
technical examples. This pattern can also be applied within the",
    "metadata": {

```

```

        "source": ".config/ska/local/data/books/[Eric Evans] (2003) Domain Driven
Design Tackling Complexity in the Heart of Software/[Eric Evans] (2003) Domain Driven
Design Tackling Complexity in the Heart of Software.pdf"
    }
}
],
"question": "what is a database?",
"answer": " A database is a collection of data stored in a structured and organized
manner, typically in a digital format. It can be used to store and manage large amounts of
data, such as customer information, financial transactions, or inventory levels. A database
can be accessed and manipulated using various techniques, such as SQL (Structured Query
Language) or NoSQL databases. The data in a database is typically organized into tables
or schemas, with each table containing a set of rows or records that represent individual
instances of a particular entity or object. The relationships between these entities can
be defined using foreign keys, which link related tables together. The database can be
used to create, read, update, and delete (CRUD) operations on the data it contains."
}

```

Asking a simpler question to our custom SKA text generation model

`rag-invoke --emb-name all-MiniLM-L6-v2 --llm-name skalm --question "what is domain driven design?"` does not return any context. We see that our model which was trained only with a single book and was designed with a small depth of layers with small parameters does not answer very good.

```

{
  "context": [],
  "question": "what is domain driven design?",
  "answer": "a pattern is that it is not a solution to the model . \n the team can
readily distinguish two models . \n the developer was able to respond to the model and the
design . \n the team had encountered in the model , the team had given a new concept . \n
the model is a set of concepts that can be integrated by the domain experts , the bones of
the model is the same concept . \n the team may not be a very deep model for the domain .
\n"
}

```

5.2. Graphical User Interface (GUI) Usage

We showcased the usage of our command line application. After the deployment, the admin downloads and inserts the models, creates and trains the SKA text generation model and prepares the RAG vector store. Now the system is ready to be used by its users by accessing the Graphical User Interface that has been deployed. We will show the main pages of our app and the core functionality of the Specific Knowledge Assistant.

The Home page is the first page a user sees. It shows a brief description of the application. It also allows users to login to the system by either clicking the link in the page content or by revealing the users account dropdown at the top right of the page.

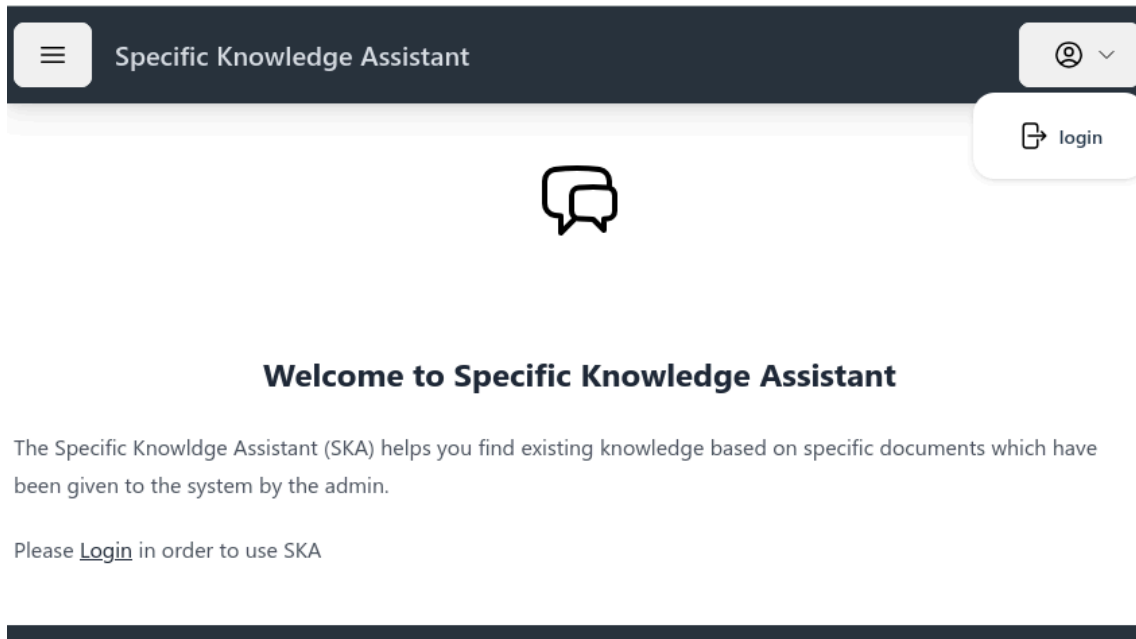

IMAGE 13: SKA Home Page

When users click the login link, they get redirected to the Keycloak login page. There they can login with their credentials and the Keycloak will redirect them back to the SKA home page.

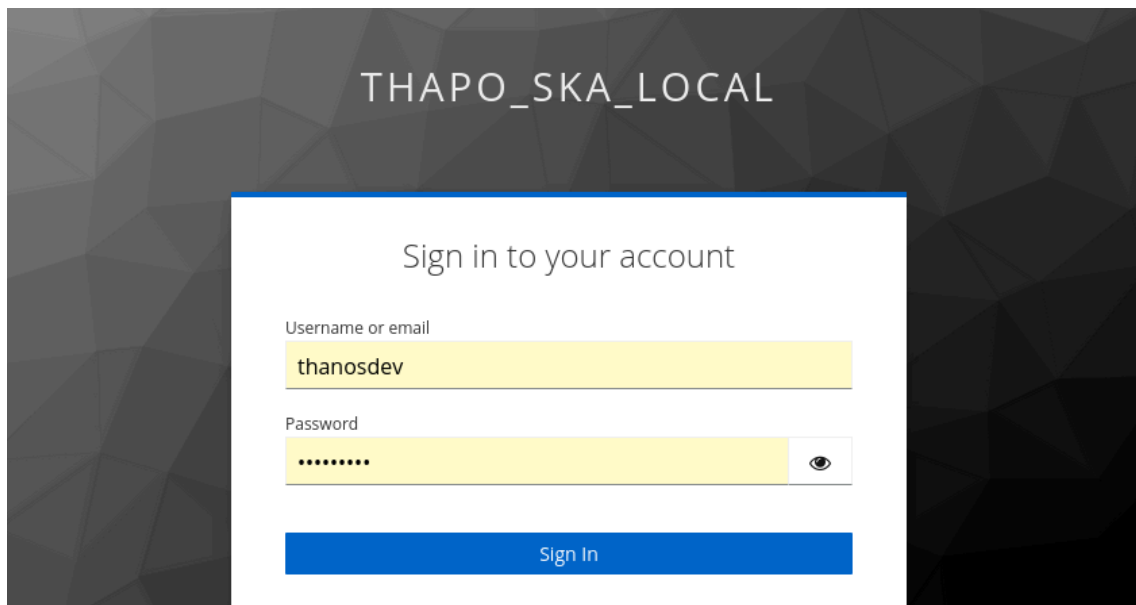

IMAGE 14: SKA Keycloak Login

Now that users are logged in the Home page content changes in order to show a link to the Assistant page. The top right account dropdown also changes in order to enable user to logout or navigate the account info page.

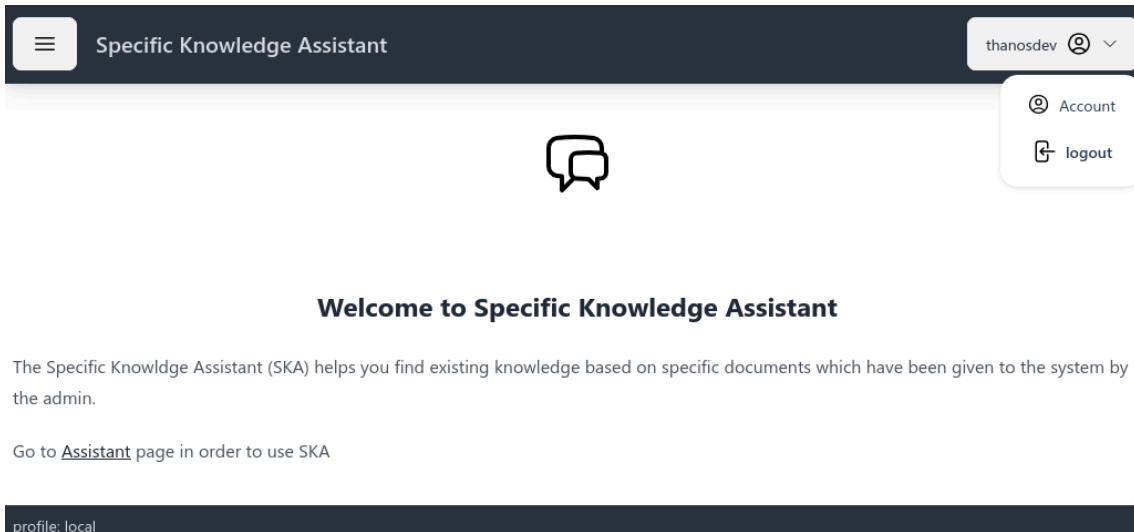

IMAGE 15: SKA Home Page and Account Dropdown with logged in user

The top left header menu now shows the Assistant page as an option for navigation too.

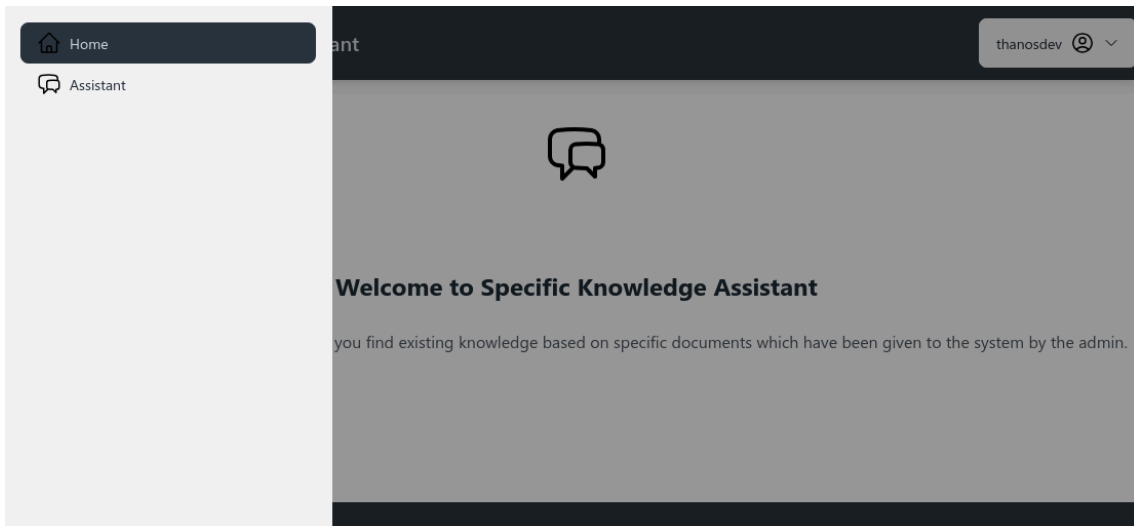

IMAGE 16: SKA Home Page and Toolbar Menu with logged in user

In the Account page users can see their basic account information together with their assigned roles. The “Manage Account” button will navigate users to the respective Keycloak page for account management.

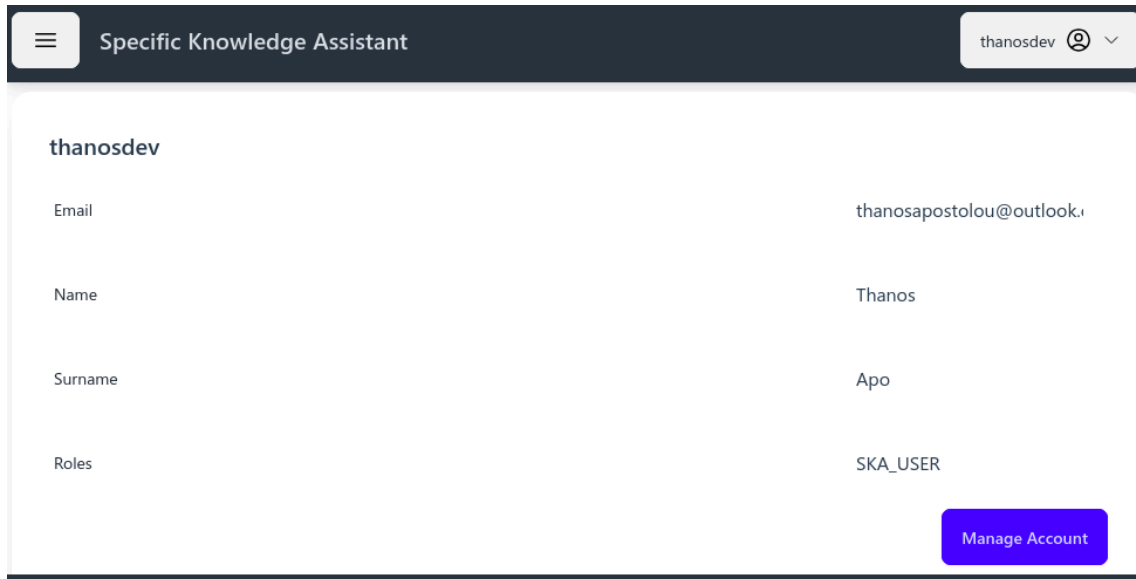

IMAGE 17: SKA Account Page

In the Keycloak account management page users can edit their personal information like first name, last name and email. Users can also see other information like their signed in devices. When users have finished with their changes they can click the link “Back to thapo_ska_local_frontend” at the top in order to be navigated back to SKA application GUI.

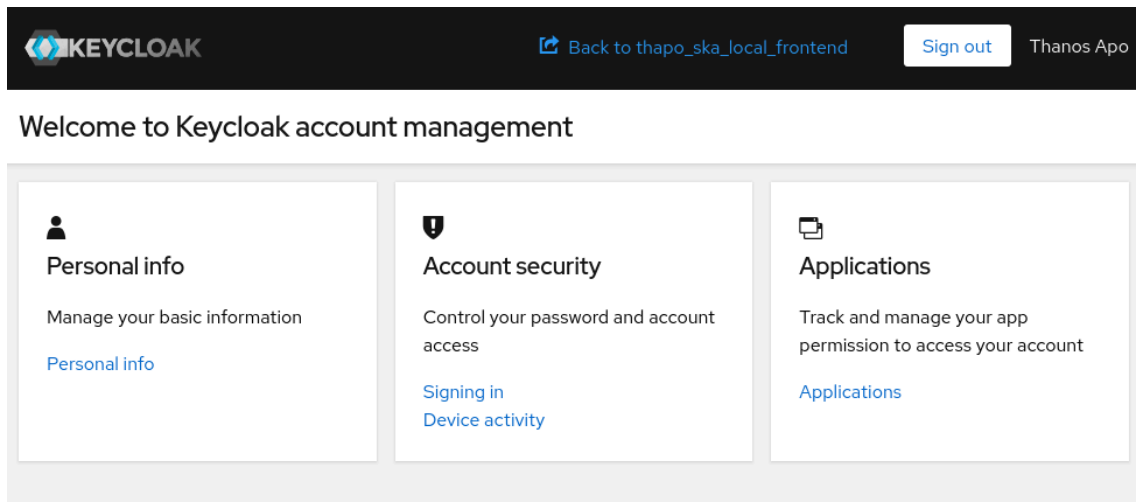

IMAGE 18: Keycloak Account Page

The most important page of our application is the Assistant Page. Initially, for users this page does not include any chats, but it asks them to create some in order to be able to ask questions.

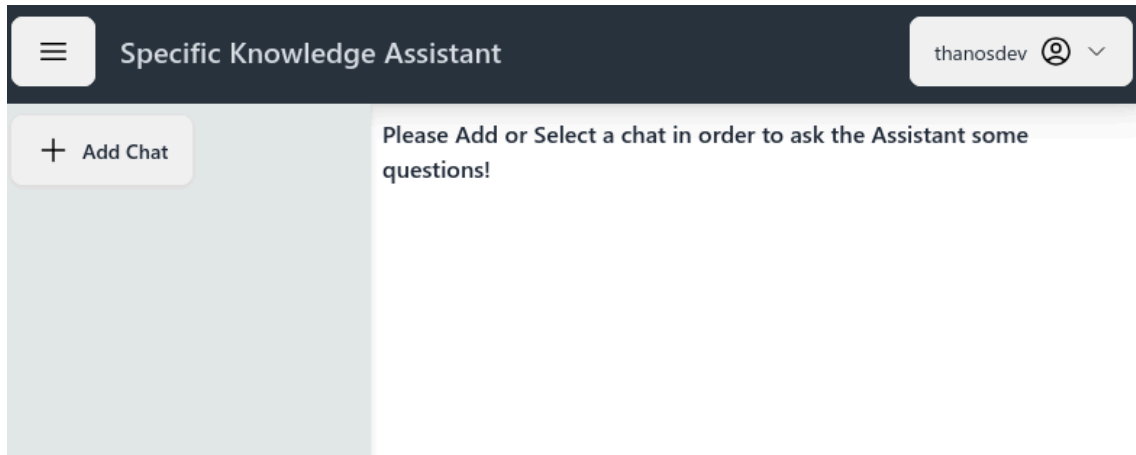

IMAGE 19: Assistant Page

When users click the “Add Chat” button, a dialog appears which asks them to select an LLM and enables them to edit some parameters. For a start, we will select our custom text generation model `skalm` which does not support any parameters. The system enables us to create multiple chats with the same LLM, so we will give the chat the name “our_skalm” so that we can recognize it. We can select the newly created “our_skalm” and delete it or edit it by using a similar dialog with the “Add Chat” dialog.

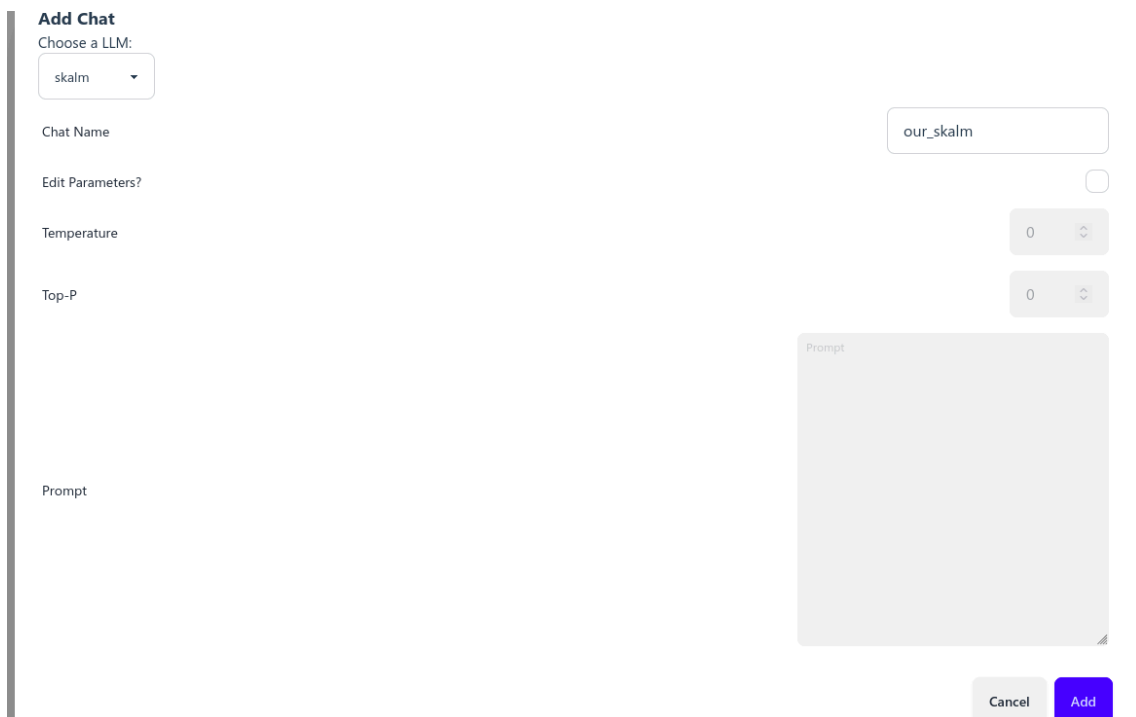

IMAGE 20: Assistant Add Chat Dialog

We select the chat we created “our_skalm”. Any new chat starts with an answer of the assistant “Please ask me anything related to this field”. We ask the same question we used when we showcased the CLI app “what is domain driven design?”. As before, the answer is not very satisfying for the reasons we have already explained. The model does not support showing the relevant context references either.

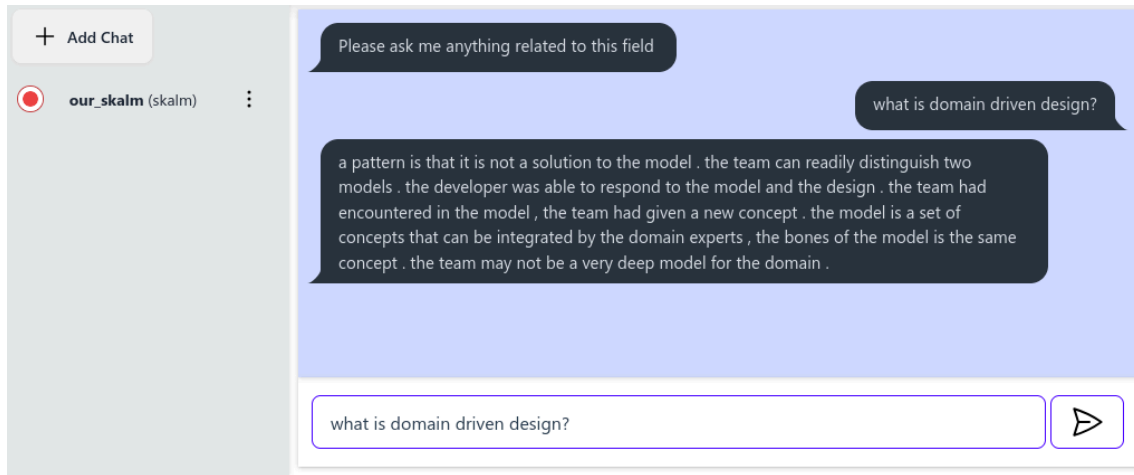

IMAGE 21: Assistant our_skalm Chat

We will not use our custom text generation model any more, but we will focus on the models that are used for the RAG method. We will create now a chat called “our_llama3” using the latest Llama3-8B LLM (the quantized version we have already described when we download it using our cli app). We will use the default values for the parameters. We set values 0 for “Temperature” and “Top-p” parameters in order to minimize the randomness of the answer, as we desire to give the same answers for the same questions with the same context. The default prompting template we are using for Llama-3 is the following, which tries to guide the LLM to answer only based on the provided context and not based on its own knowledge from training.

```
<|begin_of_text|><|start_header_id|>system<|end_header_id|>
You are an assistant for question-answering tasks. Use the following pieces of retrieved
context to answer the question. If you don't know the answer, just say that you don't
know. Use three sentences maximum and keep the answer concise.<|eot_id|><|start_header_id|
>user<|end_header_id|>
Context: {context}. Question: {question}<|eot_id|><|start_header_id|>assistant<|
end_header_id|>
```

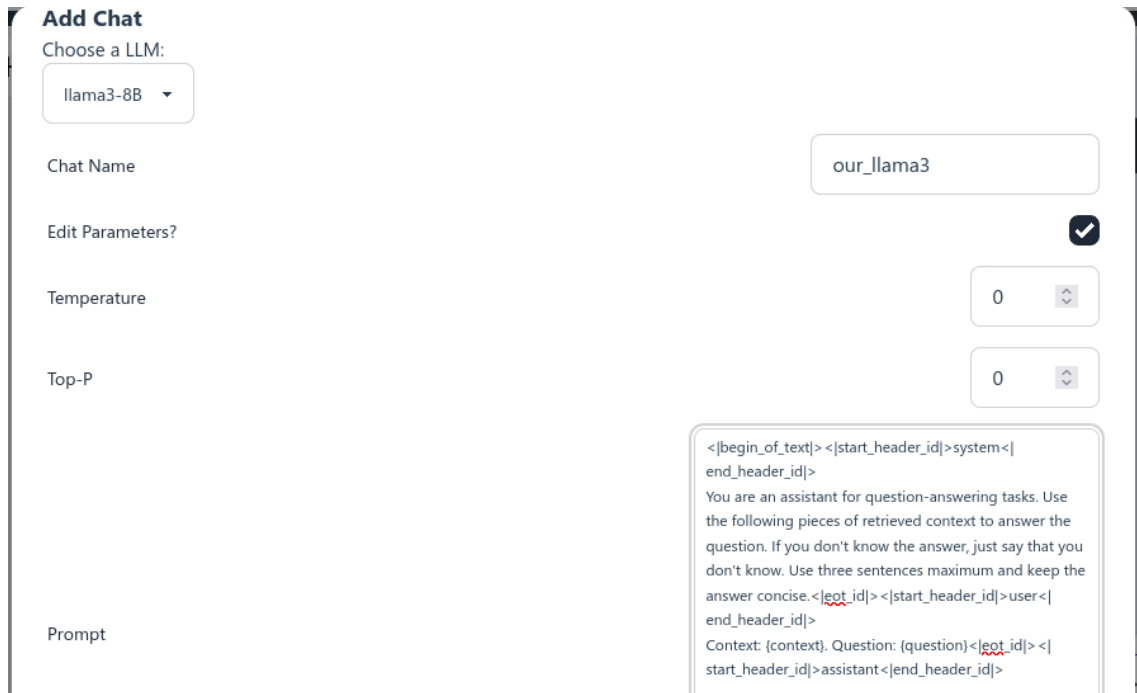

IMAGE 22: Assistant Add Llama3 Chat

We select the chat we created “our_llama3”. We ask the same question that we asked skalm model “what is domain driven design?”. We also ask a second question “what is a database?”. We see that the answers are much better in comparison with skalm model.

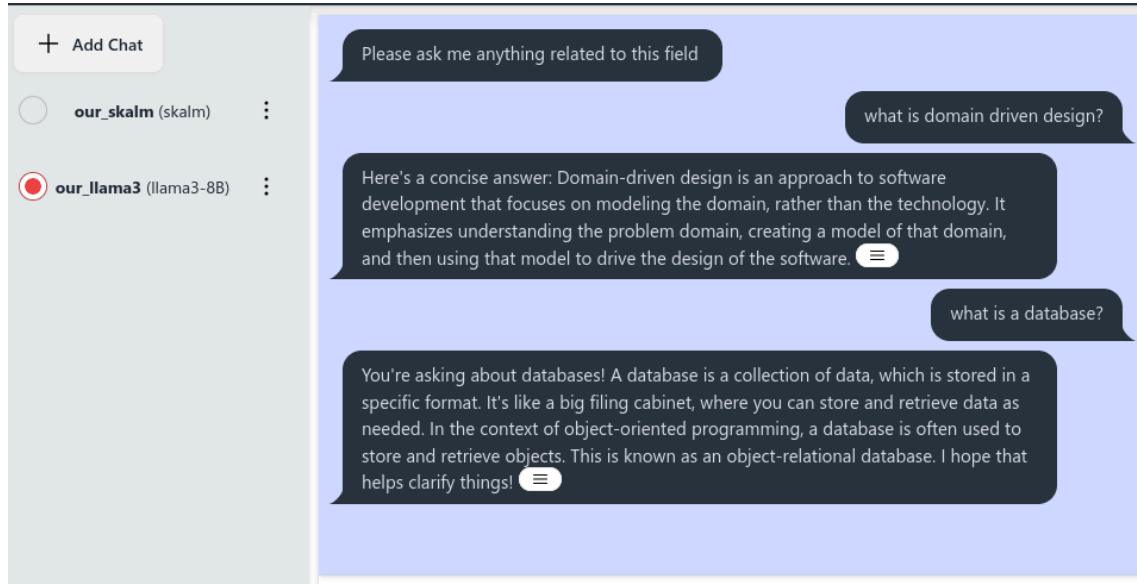

IMAGE 23: Assistant our_llama3 Chat

When chats are used with supported by RAG models, the answers have a little button at the end of them. Clicking on this button opens a modal that shows the context with the relevant chunks of which the model found the answer. So, it enables the users to cross reference their documents and verify the LLM answers.

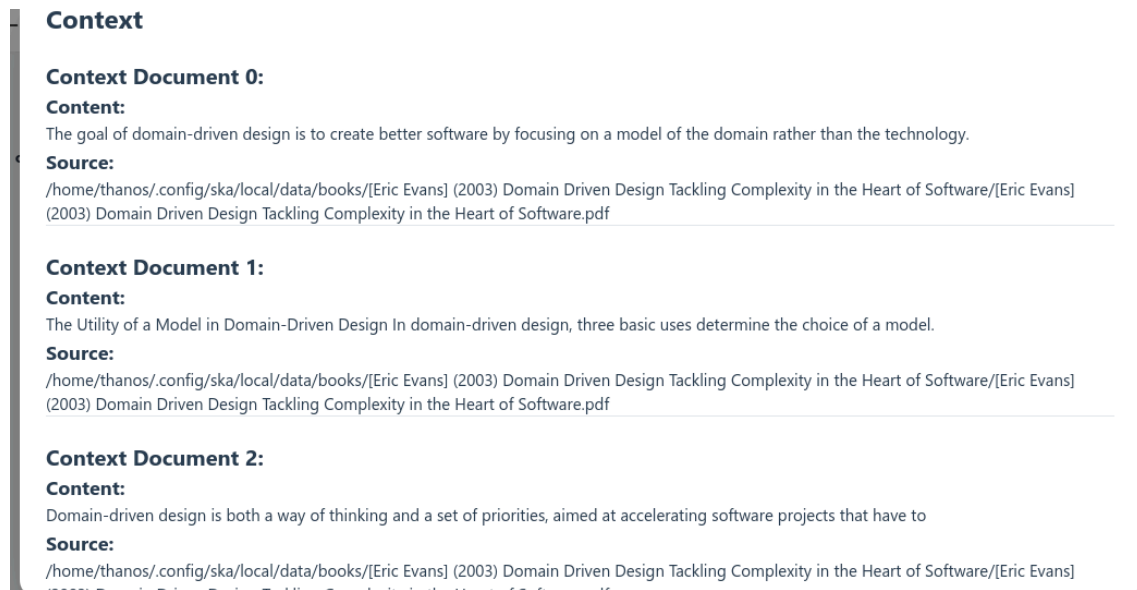

IMAGE 24: Assistant our_llama3 Context Modal

Users can experiment with LLMs “Temperature”, “Top-p” and “Prompting Template” parameters in order to achieve their wanted behavior for the task of knowledge search and assistance! We have completed the showcase of the most important parts of our application.

6. Conclusions and Future Work

We studied the usage of text generation machine learning models in specific knowledge search and analysis assistance. We used two different methods to accomplish these tasks. The first method involved the creation of a custom text generation machine learning model. We trained this model with users' documents for the specific knowledge field and we tried to make it possible to answer users' questions about this knowledge field. The second approach was based on the Retrieval Augmented Generation (RAG) technique. We used pre-trained Large Language Models (LLMs), we provided the users' documents as context to these LLMs and we tried to make them answer based only on this context and not based on their knowledge acquired by their training.

Then, we developed a full web application and a complete system with its own infrastructure in order to support users to utilize this knowledge search and assistance, in a specific knowledge field constructed by various documents of different formats. The admin was able to use the Command Line Interface (CLI) application in order to administrate the system, manage the needed LLMs and add/delete/update the users' documents. The users were able to use the Graphical User Interface (GUI) and utilize the Specific Knowledge Assistant (SKA) by asking questions relevant to the knowledge field.

After using the system and researching ways to improve its capabilities and tune its performance we reached in the following conclusions.

- Our custom text generation model was not able to perform well in answering questions. This was expected since the model needed to learn from scratch all the vocabulary and grammar of the language in addition the specific field of knowledge. The depth of the model architecture, the training time and the users' documents we had available for training were not enough in order to achieve this goal.
- The method using a custom text generation model is not suitable for this task. Even if we managed to make our model to perform well, each time the users' documents were updated we will need to retrain the model in these documents, a procedure very costly in terms of time, resources and energy wasted.
- The method using the RAG technique achieved the desired outcome. Users were able to get answers for their questions and be provided with the relative context of the information so that can deep dive into or even cross check the answer.
- The whole system and infrastructure can be self hosted without any dependency on any other external or paid service. We were able to download free high performant LLMs locally to our self hosted server and deploy our whole application and the needed infrastructure using Docker and Kubernetes. Utilizing Kubernetes allows us to move the system to a managed external paid Kubernetes service if we ever need higher resources and availability in the future, with very little changes.
- We need very high resources for a good user experience. We managed our system to work somehow well by using lighter quantized machine learning models versions instead of the original with the trade-off of losing accuracy. However, with multiple users' documents and larger chunks splits in our vector store (which gives us in better results) the system needs several minutes sometimes to answer some questions. We understand that we need to utilize a GPU (which our hardware didn't support) instead of just using the CPU. Also the memory requirements increase as well with the minimum being around 3GB of RAM.

The Specific Knowledge Assistance (SKA) was able to achieve its goals. However, this only the beginning since machine learning and specifically RAG technique will increase in popularity more and more as the years goes by, with many researchers trying to advance its capabilities and to

mitigate its disadvantages. With this in mind, there are several improvements and changes we can apply in the future after the completion of this thesis:

- Deprecate support of the custom text generation model. As we concluded before, the custom text generation model method had many drawbacks and wasn't able to perform well. Supporting both RAG and our custom text generation model limited the system and didn't allow us to fully take advantage of RAG technique.
- Utilize a supported GPU. We will need to acquire high performance hardware with GPU capabilities and deploy the system with some changes in order to support GPU during both the vector store creation and the invocation of the LLMs during. This will vastly improve the user experience.
- Support more generation formats like images, sounds and videos. We only focused on text generation task on this thesis. However, newer machine learning models are being developed that support generation of images, sound and videos. In the future we will be able to update the system in order to support generation of these types and not just text. This will be very useful in some knowledge fields.
- Add integrations with other applications and utilize interfaces which enables us to interact with the external world. The langchain library we used has the concept of `Tools` [82] which allows more advanced information to be passed in the LLMs programmatically. We didn't use these Tools since they are not very mature yet in development and their usage is very advanced for this thesis goals. However, in the future we would be able to expand the system and find information by other systems and not just documents.

We achieved the goal of knowledge assistance in a specific knowledge field using artificial intelligence technologies. We believe that the system we created can form a future basis and be expanded in order to be able to perform more complex tasks!

Bibliography

- [1] H. Face, "Text Generation." [Online]. Available: <https://huggingface.co/tasks/text-generation>
- [2] Wikipedia, "Artificial intelligence." [Online]. Available: https://en.wikipedia.org/wiki/Artificial_intelligence
- [3] S. Russell and P. Norvig, *Artificial Intelligence: A Modern Approach*, 4th Global Edition. Pearson, 2021.
- [4] Wikipedia, "Machine Learning." [Online]. Available: https://en.wikipedia.org/wiki/Machine_learning
- [5] GeeksforGeeks, "Types of Machine Learning." [Online]. Available: <https://www.geeksforgeeks.org/types-of-machine-learning>
- [6] lakeFS, "Machine Learning Components: Elements & Classifications." [Online]. Available: <https://lakefs.io/blog/machine-learning-components/>
- [7] J. Holdsworth and M. Scapicchio, "Deep learning." [Online]. Available: <https://www.ibm.com/topics/deep-learning>
- [8] Amazon, "Deep learning." [Online]. Available: <https://aws.amazon.com/what-is/deep-learning/>
- [9] R. Khalkar, A. S. Dikhit, and A. Goel, "Handwritten Text Recognition using Deep Learning (CNN & RNN)," *International Advanced Research Journal in Science, Engineering and Technology*, 2021, [Online]. Available: https://www.researchgate.net/publication/353939315_Handwritten_Text_Recognition_using_Deep_Learning_CNN_RNN
- [10] javatpoint, "Applications of Machine learning." [Online]. Available: <https://www.javatpoint.com/applications-of-machine-learning>
- [11] GeeksforGeeks, "Applications of Machine learning." [Online]. Available: <https://www.geeksforgeeks.org/machine-learning-introduction/>
- [12] C. Staff, "10 Machine Learning Applications." [Online]. Available: <https://www.coursera.org/articles/machine-learning-applications>
- [13] I. Goodfellow, Y. Bengio, and A. Courville, *Artificial Intelligence: Deep learning - adaptive computation and machine learning*. 2016.
- [14] K. Martineau, "What is generative AI." [Online]. Available: <https://research.ibm.com/blog/what-is-generative-AI>
- [15] Cloudflare, "What is a large language model (LLM)." [Online]. Available: <https://www.cloudflare.com/learning/ai/what-is-large-language-model/>
- [16] Ruman, "Setting Top-K, Top-P and Temperature in LLMs." [Online]. Available: <https://rumn.medium.com/setting-top-k-top-p-and-temperature-in-llms-3da3a8f74832>
- [17] A. Verma, "Understanding temperature, top_p, top_k, logit_bias in LLM parameters." [Online]. Available: <https://aviralrma.medium.com/understanding-llm-parameters-c2db4b07f0ee>
- [18] K. Talamadupula, "A Guide to Quantization in LLMs." [Online]. Available: <https://sybl.ai/developers/blog/a-guide-to-quantization-in-llms/>

- [19] LangChain, "Build a Retrieval Augmented Generation (RAG) App." [Online]. Available: <https://python.langchain.com/v0.2/docs/tutorials/rag/>
- [20] Amazon, "What is Retrieval-Augmented Generation." [Online]. Available: <https://aws.amazon.com/what-is/retrieval-augmented-generation/>
- [21] Wikipedia, "Python (programming language)." [Online]. Available: [https://en.wikipedia.org/wiki/Python_\(programming_language\)](https://en.wikipedia.org/wiki/Python_(programming_language))
- [22] Amazon, "What is Python." [Online]. Available: <https://aws.amazon.com/what-is/python/>
- [23] GeeksforGeeks, "Python Language advantages and applications." [Online]. Available: <https://www.geeksforgeeks.org/python-language-advantages-applications/>
- [24] Wikipedia, "Rust (programming language)." [Online]. Available: [https://en.wikipedia.org/wiki/Rust_\(programming_language\)](https://en.wikipedia.org/wiki/Rust_(programming_language))
- [25] Rust, "Rust." [Online]. Available: <https://www.rust-lang.org/>
- [26] C. Mittal, "10 Best Use Cases of Rust Programming Language in 2023." [Online]. Available: <https://medium.com/@chetanmittaldev/10-best-use-cases-of-rust-programming-language-in-2023-def4e2081e44>
- [27] M. Tawfik, "Rust Language: Pros, Cons, and Learning Guide." [Online]. Available: <https://medium.com/@apicraft/rust-language-pros-cons-and-learning-guide-594e8c9e2b7c>
- [28] N. Project, "Natural Language Toolkit." [Online]. Available: <https://www.nltk.org/>
- [29] N. Project, "Installing NLTK Data." [Online]. Available: <https://www.nltk.org/data.html>
- [30] Wikipedia, "PyTorch." [Online]. Available: <https://en.wikipedia.org/wiki/PyTorch>
- [31] N. Corporation, "PyTorch." [Online]. Available: <https://www.nvidia.com/en-eu/glossary/pytorch/>
- [32] LangChain, "Introduction." [Online]. Available: <https://python.langchain.com/v0.2/docs/introduction/>
- [33] LangChain, "LLMs." [Online]. Available: https://python.langchain.com/v0.1/docs/modules/model_io/llms/
- [34] LangChain, "Vector stores." [Online]. Available: https://python.langchain.com/v0.1/docs/modules/data_connection/vectorstores/
- [35] HuggingFace, "Hugging Face Hub documentation." [Online]. Available: <https://huggingface.co/docs/hub/index>
- [36] G. Gerganov, "llama.cpp." [Online]. Available: <https://github.com/ggerganov/llama.cpp>
- [37] G. Gerganov, "ggml." [Online]. Available: <https://github.com/ggerganov/ggml/blob/master/README.md>
- [38] ivanov, M. Brett, and mdboom2, "matplotlib." [Online]. Available: <https://pypi.org/project/matplotlib/>
- [39] U. Technologies, "unstructured." [Online]. Available: <https://pypi.org/project/unstructured/>
- [40] M. Douze and L. Hosseini, "faiss." [Online]. Available: <https://pypi.org/project/unstructured/>
- [41] E. Page and K. K., "clap." [Online]. Available: <https://github.com/clap-rs/clap/blob/master/README.md>

- [42] C. Lerche, "tokio." [Online]. Available: <https://github.com/tokio-rs/tokio/blob/master/README.md>
- [43] D. Pedersen and J. Platte, "axum." [Online]. Available: <https://github.com/tokio-rs/axum/blob/main/README.md>
- [44] B. Chan and C. Tsang, "SeaORM." [Online]. Available: <https://github.com/SeaQL/sea-orm/blob/master/README.md>
- [45] SeaQL.org, "Database Connection." [Online]. Available: <https://www.sea-ql.org/SeaORM/docs/install-and-config/connection/>
- [46] M. contributors, "SPA (Single-page application)." [Online]. Available: <https://developer.mozilla.org/en-US/docs/Glossary/SPA/>
- [47] M. contributors, "CSS: Cascading Style Sheets." [Online]. Available: <https://developer.mozilla.org/en-US/docs/Web/CSS>
- [48] M. contributors, "JavaScript." [Online]. Available: <https://developer.mozilla.org/en-US/docs/Web/JavaScript>
- [49] M. contributors, "TypeScript." [Online]. Available: <https://developer.mozilla.org/en-US/docs/Glossary/TypeScript>
- [50] M. contributors, "HTML: HyperText Markup Language." [Online]. Available: <https://developer.mozilla.org/en-US/docs/Web/HTML>
- [51] E. You, "Introduction." [Online]. Available: <https://vuejs.org/guide/introduction>
- [52] S. Susnjara and I. Smalley, "What are containers?." [Online]. Available: <https://www.ibm.com/topics/containers>
- [53] D. Inc, "Get Docker." [Online]. Available: <https://docs.docker.com/get-docker/>
- [54] D. Inc, "Docker Engine overview." [Online]. Available: <https://docs.docker.com/engine/>
- [55] D. Inc, "Overview of Docker Build." [Online]. Available: <https://docs.docker.com/build/>
- [56] D. Inc, "Docker Compose overview." [Online]. Available: <https://docs.docker.com/compose/>
- [57] T. K. Authors, "kubernetes." [Online]. Available: <https://kubernetes.io/>
- [58] T. K. Authors, "Overview." [Online]. Available: <https://kubernetes.io/docs/concepts/overview>
- [59] P. Contributors, "Embedding." [Online]. Available: <https://pytorch.org/docs/stable/generated/torch.nn.Embedding.html>
- [60] D. P. Kingma and J. Ba, "Adam: A Method for Stochastic Optimization." [Online]. Available: <https://arxiv.org/abs/1412.6980>
- [61] P. Contributors, "CrossEntropyLoss." [Online]. Available: <https://pytorch.org/docs/stable/generated/torch.nn.CrossEntropyLoss.html>
- [62] E. Evans, *Domain Driven Design Tackling Complexity in the Heart of Software*, 1st ed. Addison-Wesley, 2004.
- [63] LangChain, "Text embedding models." [Online]. Available: https://python.langchain.com/v0.1/docs/modules/data_connection/text_embedding/
- [64] N. Reimers, O. Espejel, P. Cuenca, and T. Aarsen, "all-MiniLM-L6-v2." [Online]. Available: <https://huggingface.co/sentence-transformers/all-MiniLM-L6-v2>

- [65] LangChain, "Chains." [Online]. Available: <https://python.langchain.com/v0.1/docs/modules/chains/>
- [66] LangChain, "Returning sources." [Online]. Available: https://python.langchain.com/v0.1/docs/use_cases/question_answering/sources/
- [67] K. Authors, "Keycloak." [Online]. Available: <https://www.keycloak.org/>
- [68] T. P. G. D. Group, "PostgreSQL." [Online]. Available: <https://www.postgresql.org/>
- [69] T. Jobbins, "Llama-2-7B-Chat-GGUF." [Online]. Available: <https://huggingface.co/TheBloke/Llama-2-7B-Chat-GGUF>
- [70] P. Bendus, A. Kotliar, and C. Crowley, "Meta-Llama-3-8B-Instruct-GGUF." [Online]. Available: <https://huggingface.co/SanctumAI/Meta-Llama-3-8B-Instruct-GGUF>
- [71] E. You and E. S. M. Morote, "Vue Router." [Online]. Available: <https://router.vuejs.org/>
- [72] M. contributors, "Ajax." [Online]. Available: <https://developer.mozilla.org/en-US/docs/Glossary/AJAX>
- [73] J. J. "Jake" Sarjeant and M. Zabriskie, "Axios." [Online]. Available: <https://axios-http.com/>
- [74] P. Luginbühl, "oidc-client-ts." [Online]. Available: <https://auths.github.io/oidc-client-ts/>
- [75] K. Authors, "Keycloak OAuth2 PKCE." [Online]. Available: <https://frameworks.readthedocs.io/en/latest/spring-boot/spring-boot2/keycloakOAuth2PKCE.html>
- [76] nginx, "nginx." [Online]. Available: <https://nginx.org/en/>
- [77] T. K. Authors, "INGress." [Online]. Available: <https://kubernetes.io/docs/concepts/services-networking/ingress/>
- [78] Wikipedia, "CI/CD." [Online]. Available: <https://en.wikipedia.org/wiki/CI/CD>
- [79] Jenkins, "Jenkins." [Online]. Available: <https://www.jenkins.io/>
- [80] K. P. Authors, "K3s." [Online]. Available: <https://k3s.io/>
- [81] H. Authors, "Helm." [Online]. Available: <https://helm.sh/>
- [82] LangChain, "Tools." [Online]. Available: <https://python.langchain.com/v0.1/docs/modules/tools/>