



University of Piraeus  
Department of Digital Systems  
Postgraduate Programme "Digital Communications & Networks "

# WIFI EVOLUTION "BEYOND WIFI 6"

Master's thesis  
Digital Communications & Networks

Balkonis Michail  
mwe1905  
Supervisor: Angeliki Alexiou

Athens, June 2021

***This thesis is dedicated to my  
beloved sister Elli  
as well as my parents who gave us  
all the supplies...***

## TABLE OF CONTENTS

<b>TABLE OF CONTENTS</b> .....	3
<b>List of Abbreviations</b> .....	6
<b>Acknowledgements</b> .....	8
<b>ABSTRACT</b> .....	9
<b>ΠΕΡΙΛΗΨΗ</b> .....	10
<b>1. INTRODUCTION IN WIRELESS TECHNOLOGY</b> .....	11
<b>1.1 Brief History of Wireless Technology</b> .....	13
<b>1.2 IEEE 802.11 Architecture</b> .....	13
<b>1.2.1 Station</b> .....	13
<b>1.2.2 Access Point</b> .....	13
<b>1.2.3 Wireless Medium</b> .....	14
<b>1.3 Architectures</b> .....	14
<b>1.4 Evolution of the standard 802.11</b> .....	16
<b>1.5 IEEE 802.11 Physical Layer</b> .....	21
<b>1.5.1 Physical layer (phy) frame structure</b> .....	22
<b>1.5.2 Operating Physical Layer</b> .....	23
<b>1.6 Medium Access Control (MAC) Layer &amp; Key Technologies</b> .....	24
<b>1.6.1 Distributed Coordination Function (DCF)</b> .....	24
<b>2. INTRODUCTION OF WI FI 6 (802.11AX)</b> .....	26
<b>2.1 Can 802.11ax go so fast?</b> .....	27
<b>2.2 Design Goals of Wi-Fi 6</b> .....	28
<b>2.3 New Features in Wi-Fi 6</b> .....	29
<b>2.4 Overview of Wi-Fi 6</b> .....	30
<b>2.5 Physical Enhancements Overview of 802.11ax</b> .....	32
<b>2.5.1 New modulation technology</b> .....	33
<b>2.5.2 New Coding Strategy</b> .....	36
<b>2.5.3 New Mechanism Subcarrier Division</b> .....	36
<b>2.5.4 Enhanced Multiple Access Technology</b> .....	37
<b>2.5.5 Channel Bonding Enhancement</b> .....	44
<b>2.5.6 New Headers PPDU</b> .....	47

2.6	BSS Coloring.....	49
2.6.1	What is BSS Coloring? .....	50
2.6.2	BSS coloring (Benefits and Advantages).....	50
2.7	Target Wake Time.....	51
2.8	Use Cases for Wi-Fi 6 Technology .....	52
2.9	User Experience of Wi-Fi 6 .....	53
2.10	Advantages in Wi-Fi 6 .....	53
2.11	Disadvantages in Wi-Fi 6.....	54
3.	THE FUTURE OF WI-FI .....	55
3.1	Wi-Fi 6E: “The New Lane” .....	55
3.2	The Importance of 6GHz .....	55
3.3	IEEE 802.11ax/be Frequency Bands .....	56
3.4	Benefits of 6 GHz .....	56
3.5	6 GHz Wi-Fi Challenges and Strategics .....	57
4.	802.11BE WI-FI 7: EXTREMELY HIGH THROUGHPUT .....	58
4.1	Evolution to Wi-Fi 7 .....	58
4.2	How Extreme High Throughput can be achieved ?.....	59
4.3	The Development Timeline of IEEE 802.11be.....	60
4.3.1	Release 1 Features .....	61
4.3.2	Release 2 Features .....	63
4.4	Physical Frame .....	65
4.5	The MAC Layer.....	68
4.5.1	Multi-link operation.....	68
4.5.2	enhancements of Spatial streams and MIMO .....	74
4.5.3	Multi-Ap Features .....	75
4.5.4	HARQ .....	78
4.5.5	Non-Orthogonal Multiple Access .....	80
4.5.6	The Channel Sounding.....	81
4.6	Physical Enhancements for EHT .....	83
4.6.1	New Bandwidth Mode .....	85
4.6.2	Support Multi RU .....	87
4.6.3	Preamble Design of Extremely High Throughput.....	88
4.6.4	Higher-Order Modulation.....	90

4.7	Summary of Wi-Fi 7 .....	91
5.	TIME-SENSITIVE NETWORKING (TSN) .....	93
5.1	Improvements to support time synchronization.....	96
5.2	Improvements to support traffic shaping and scheduling.....	96
5.3	Improvements to support ultra – reliability.....	98
5.4	Improvements to support resource management .....	98
5.5	Use Cases of Time-Sensitive Networking in Wi Fi 7.....	101
5.5.1	Multimedia .....	102
5.5.2	Health Care .....	103
5.5.3	Industry 4.0.....	103
5.5.4	Transport .....	104
5.5.5	Interactive museum .....	104
6.	PERFORMANCE RESULTS .....	105
7.	CONCLUSION.....	144
	References .....	145

**LIST OF ABBREVIATIONS**

<b>ACK</b>	Acknowledgment (ACK)
<b>AP</b>	Access Point
<b>AR</b>	Augmented Reality
<b>ACK</b>	Acknowledgment
<b>ARQ</b>	Automatic Repeat Request
<b>BSS</b>	Basic Service Set
<b>BCC</b>	Binary Convolutional Coding
<b>BFR</b>	Beamforming Reports
<b>CSMA/CA</b>	Carrier-Sense Multiple Access/ Collision Avoidance
<b>CDF</b>	Cumulative Distribution Function
<b>CC</b>	Chase Combining
<b>CW</b>	Codeword
<b>CCA</b>	Clear Channel Assessment
<b>CCK</b>	Complementary Code Keying
<b>COEX SC</b>	Coexistence Standing Committee
<b>CSR</b>	Coordinated spatial reuse
<b>DIFS</b>	Distributed Inter – Frame Space
<b>DCM</b>	Dual Carrier Modulation
<b>DC</b>	Direct Current
<b>DSCP</b>	Differentiated Services Field Codepoints
<b>DS</b>	Distribution System
<b>EDCA</b>	Enhanced Distributed Channel Access
<b>ESS</b>	Extended – Service Set
<b>EC</b>	European Commission
<b>FCC</b>	Federal Communications Commission
<b>FHSS</b>	Frequency Hopping Spread Spectrum
<b>FST</b>	Fast Session Transfer
<b>GI</b>	Guard Interval
<b>HCCA</b>	Hybrid Coordination Function Controlled Channel Access
<b>ISM</b>	Industrial, Scientific & Medical (Band)
<b>WISPs</b>	Internet Service Providers
<b>LDPC</b>	Low Density Parity Check
<b>LLC</b>	Logical Link Control
<b>MLD</b>	Multi-link device
<b>MSDU</b>	MAC service data unit
<b>MCSs</b>	Modulation and Codification Schemes
<b>mmWave</b>	Millimeter Waves

<b>NPRM</b>	Notice of Proposed Rulemaking
<b>NDP</b>	Null Data Packet
<b>NDPA</b>	Null Data Packet Announcement
<b>OBSS</b>	Overlapping Basic Service Set
<b>OEM</b>	Original Equipment Manufacturers
<b>PN</b>	Packet Number
<b>PAPR</b>	Peak to Average Power Ratio
<b>PD</b>	Packet Detection
<b>QoS</b>	Quality of Service
<b>RAT</b>	Radio Access Technology
<b>RSSI</b>	Received Signal Strength Indication
<b>RSNA</b>	Robust Security Network Associations
<b>SAP</b>	Service Access point
<b>SME</b>	Station Management Entities
<b>SIFS</b>	Short Inter – Frame Space
<b>SIC</b>	Successive Interference Constellation
<b>STA</b>	Station
<b>STR</b>	Simultaneously Transmit & Receive
<b>SFD</b>	Spec Framework Document
<b>TF</b>	Trigger Frame
<b>TIDs</b>	Traffic Identifiers
<b>TM</b>	Timing Measurement
<b>PTP</b>	Precision Time Protocol
<b>PSMP</b>	Power Save Multi-Poll
<b>U-NII</b>	Unlicensed National Information Infrastructure
<b>V2E</b>	Vehicle-to-Everything
<b>WAP</b>	Wi-Fi Protected Access
<b>Wi-Fi</b>	Wireless Fidelity
<b>WISP</b>	Wireless Internet Service Providers
<b>WLAN</b>	Wireless Local Area Networks

## ACKNOWLEDGEMENTS

At this point I would like to say a thank you to my project supervisor, Dr Angeliki Alexiou, with her advice as well as her guidance facilitated my full understanding of the wireless communication system and specifically to WIFI and the future changes will bring. It was a great pleasure working with you. I wish you health and happiness. I would like to thank the parents as I do not think I could have done so far without their support and encouragement. In all problems and difficulties, they are always by my side and my sister to give us what we need to move forward, they gave us all the supplies we need. A thank you is a little. I wish you eternal health.

To my beloved sister Elli who enriches my life with her love. This thesis is dedicated to Elli and our parents George and Irene.

I wish her a life as she has dreamed of as she is all in front of her, I will always be by her side no matter what difficulties she encounters.

Finally, I would like to thank my friends. They help me out at the lowest point in my life, I really appreciate their cares and accompany.

Finally, I would like to thank my friends who are like my second family. Their company and support really help me get away from the problems of everyday life. I really appreciate their care.



## ABSTRACT

The subject of this Thesis is the evolution of the WLAN 802.11 standard also known as WIFI. The aim of this dissertation is to report and analyze the 802.11be standard as well as the features of WIFI 6 or 802.11ax on which the development and evolution of WIFI 7 will be based.

Features of WIFI 6 will be analyzed as well as the standards, goals and future developments that WIFI 7 (802.11be) or Extremely High Throughput will bring to our society.

Chapter 1 provides a general introduction to wireless networks. We explain what wireless networks are, which we need, as well as a historical background. Continuing, the basic architecture of WLAN 802.11 is highlighted with the elements used in wireless networks. A reference is made to the specifications of the 802.11 standards. Finally, both the Physical and the MAC layer are analyzed.

Chapter 2 provides a more comprehensive overview of the 802.11ax standard, analyzing the new features as well as the design objectives. An overview of the physical improvements of the 802.11ax standard is then performed. At the end of the chapter, the cases of use are mentioned as well as the advantages, disadvantages of the 802.11ax standard.

Chapter 3 refers to the future Wi-Fi and specifically the expansion of Wi-Fi 6 in the 6GHz band with its importance and the changes it will bring. The advantages of this upgrade as well as the challenges that this development will bring are mentioned.

In Chapter 4 we refer to the future WIFI 7 and specifically to the name of Extremely High Throughput, IEEE 802.11be. This chapter will study its development schedule as defined by the WIFI community as well as the release dates of its features.

The characteristics that were to be introduced in the new technology in both the physical layer and the MAC layer will be analyzed.

In the following Chapter 5 a more detailed reference will be made to a key feature that will play a key role in future developments, namely the 802.11be Time Sensitive Network (TSN), as well as the improvements it will bring. In addition, the sectors and cases of use in our society of the TSN feature are analyzed.

In closing, some Simulations and their results will be presented.

## ΠΕΡΙΛΗΨΗ

Αντικείμενο της παρούσας Διπλωματικής Εργασίας είναι η εξέλιξη του προτύπου WLAN 802.11 γνωστό και ως WIFI. Η παρούσα μεταπτυχιακή εργασία έχει ως σκοπό την αναφορά και ανάλυση του προτύπου 802.11be καθώς και των χαρακτηριστικών του WIFI 6 ή 802.11ax πάνω στα οποία θα βασιστεί η ανάπτυξη και η εξέλιξη του WIFI 7.

Θα αναλυθούν χαρακτηριστικά του WIFI 6 καθώς τα στάνταρντ οι στόχοι και μελλοντικές εξελίξεις που θα επιφέρει το WIFI 7 (802.11be) ή αλλιώς Extremely High Throughput στην κοινωνία μας.

Στο 1<sup>ο</sup> κεφάλαιο γίνεται μια γενική εισαγωγή στα ασύρματα δίκτυα. Εξηγούμε τι είναι τα ασύρματα δίκτυα, που μας χρειάζονται, καθώς πραγματοποιείται και μια ιστορική αναδρομή. Συνεχίζοντας επισημαίνεται η βασική αρχιτεκτονική του WLAN 802.11 με τα στοιχεία που χρησιμοποιούνται στα ασύρματα δίκτυα. Πραγματοποιείται μια αναφορά στις προδιαγραφές των στάνταρντ του 802.11. Καθώς τέλος αναλύεται τόσο το Physical όσο και το MAC στρώμα.

Στο 2<sup>ο</sup> κεφάλαιο γίνεται μια εκτενέστερη επισκόπηση στο πρότυπο 802.11ax, αναλύονται τα νέα χαρακτηριστικά καθώς και οι σχεδιαστικοί στόχοι. Στη συνέχεια πραγματοποιείται μια επισκόπηση φυσικών βελτιώσεων του προτύπου 802.11ax. Ολοκληρώνοντας το κεφάλαιο αναφέρονται οι περιπτώσεις χρήσης καθώς και τα πλεονεκτήματα ,μειονεκτήματα του προτύπου 802.11ax.

Το 3<sup>ο</sup> κεφάλαιο αναφέρεται στο μελλοντικό Wi-Fi και συγκεκριμένα η επέκταση του Wi-Fi 6 στη μπάνα των 6GHz με την σημαντικότητα της και της αλλαγές τις οποίες θα επιφέρει. Αναφέρονται τα πλεονεκτήματα της αναβάθμισης αυτής καθώς και τις προκλήσεις που θα επιφέρει η εξέλιξη αυτή.

Στο 4<sup>ο</sup> κεφάλαιο κάνουμε αναφορά στο μελλοντικό WIFI 7 και συγκεκριμένα με την ονομασία του Extremely High Throughput , IEEE 802.11be. Στο κεφάλαιο αυτό θα μελετηθεί το χρονοδιάγραμμα ανάπτυξης του όπως αυτό ορίζεται από την WIFI κοινότητα καθώς και τις ημερομηνίες κυκλοφορίας των χαρακτηριστικών του.

Θα αναλυθούν τα χαρακτηριστικά που επρόκειτο να εισαχθούν στη νέα τεχνολογία τόσο στο φυσικό στρώμα όσο και στο στρώμα της MAC.

Στη Συνέχεια στο κεφάλαιο 5 θα γίνει μια εκτενέστερη αναφορά σε ένα βασικό χαρακτηριστικό που θα έχει βασική θέση στις μελλοντικές εξελίξεις , αυτό είναι Time Sensitive Network (TSN) του 802.11be, καθώς και τις βελτιώσεις τις οποίες θα επιφέρει. Επιπροσθέτως αναλύονται οι τομείς και τις περιπτώσεις χρήσης στη κοινωνία μας το χαρακτηριστικό του TSN.

Κλείνοντας θα παρουσιαστούν κάποια Simulations και τα αποτελέσματα αυτών.

## 1. INTRODUCTION IN WIRELESS TECHNOLOGY

Wireless devices working in unlicensed bands have become a necessary part of our lives today.

The Federal Communications Commission (FCC) in the US first opened the 2.4 - 2.4835 GHz and 5.725 - 5.85 GHz bands in 1985, for unlicensed access. [1]

Since then, several unlicensed radio access technologies (RATs) - most notably based Wi-Fi, Bluetooth and ZigBee have been developed that can not only operate in these bands but also coexist with each other.

The 2.4 GHz band, referred to as the Industrial, Scientific, and Medical (ISM) band, is open for unlicensed access worldwide, while unlicensed RATs such as Wi-Fi are allowed to operate in many sections of the 5 GHz bands in most regions across the world. In the US, these 5 GHz bands are referred to as the Unlicensed National Information Infrastructure (U-NII) bands.

Wi-Fi is the most popular unlicensed RAT that has the ability mobile and high-speed Internet access over wireless local area networks (WLANs).

WIFI devices are everywhere in today's home and enterprise wireless networks, with an estimated 10 billion devices.[1]

Furthermore, with the large increase in applications such as wireless virtual reality (VR), mobile gaming and augmented reality (AR), the requirement for high throughput, high reliability and low-latency WIFI connectivity keeps growing.

Consequently, unlicensed wireless spectrum is a something with major search. To cover this growing need for unlicensed spectrum, FCC in the US and the European Commission (EC) in Europe began studies to determine the feasibility of unlicensed operations in the 6 GHz bands. Specifically, the EC has been instructed a feasibility study of unlicensed operations in the 5.925-6.425 GHz band in EU.

Simultaneously, the FCC Notice of Proposed Rulemaking (NPRM) has requested comments regarding the opening up the 5.925-7.125 GHz band for unlicensed access in the US. This band in the US will be into four sub-bands: U-NII-5 (5.925–6.425 GHz), U-NII-6 (6.425–6.525 GHz), U-NII-7 (6.525–6.875 GHz), and U-NII-8 (6.875–7.125 GHz). The 6 GHz bands are considered critical in supporting emerging wireless VR, AR and mobile gaming applications, which are characterized from strict Quality of Service (QoS) requirements.

The extra spectrum that the 6 GHz bands will unlock (1.2 GHz in the US and the 500 MHz in EU) would rather increase the amount of unlicensed spectrum available in these areas. Thus, devices using the 6 GHz bands can achieve these data rates without the challenges facing in the mmWave bands (such as sensitive to blockage, high propagation losses).

In addition, plenty of empty unlicensed spectrum in the 6 GHz bands is very promising in terms of activating features & mechanisms that can support QoS sensitive Aps.

This has prompted industry stakeholders to hurry up their efforts on research and development of new mechanisms that utilize the spectrum available in the 6 GHz bands.

In the development of IEEE 802.11be, the successor to the forthcoming IEEE 802.11ax typical one of the critical goals is the efficient use of the 6 GHz bands.

The availability of the first line of Wi-Fi devices that can operate in the 6 GHz bands, which will be based on IEEE 802.11ax, has already been announced.

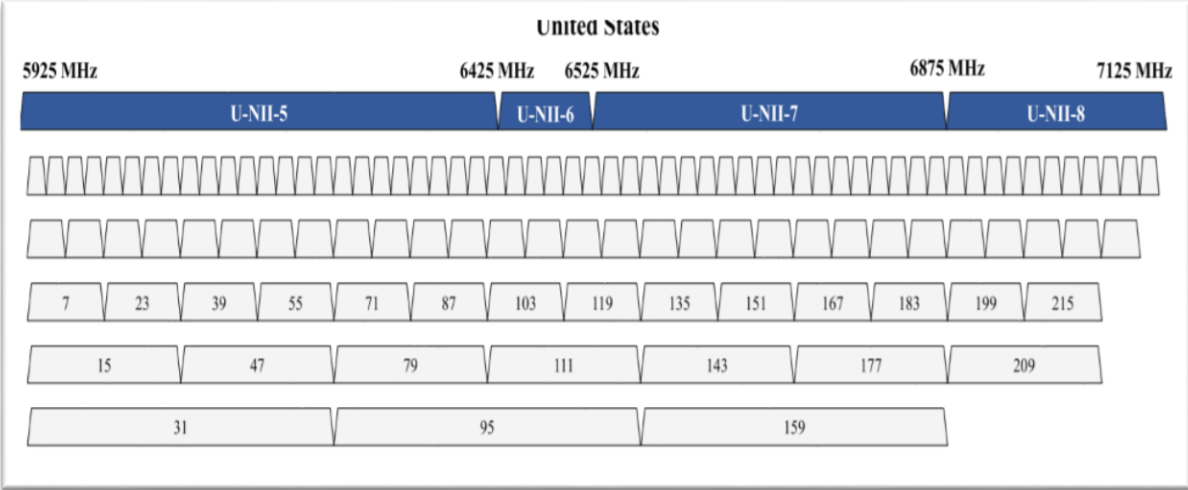

FIGURE 1 : THE 6 GHZ CHANNELS FOR UNLICENSED ACCESS IN THE US

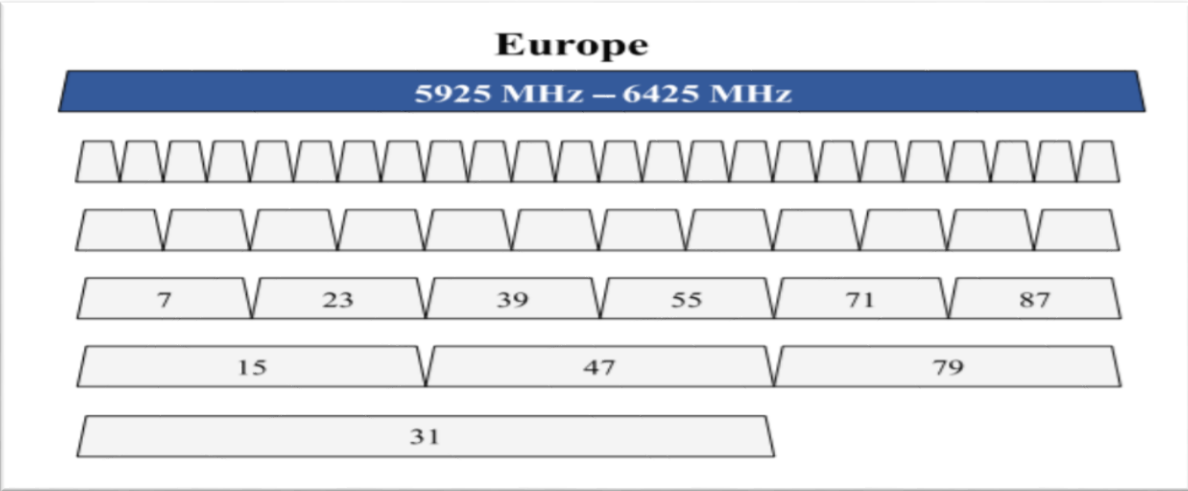

FIGURE 2 :THE 6 GHZ CHANNELS FOR UNLICENSED ACCESS IN EUROPE

## 1.1 BRIEF HISTORY OF WIRELESS TECHNOLOGY

Wireless technology is in this world for more than two centuries since the first wireless telegraph system was developed by Guglielmo Marconi in 1896 [2]. The first commercial wireless technology was launched in 1927, was the radio telephone between the UK and the US. 1946 & 1947 were two extremely important years for wireless technology. In 1946, presented the first commercial telephone service. US companies AT&T and Southwestern Bell introduced them to the private costumers. 1947 was the year that invented the transistor, which replaced vacuum tubes to communicate.

In the 1950s, the first ground microwave telecommunication system was installed to support telephone circuits. In the late 1950s, he created the first PACE paging system. Moreover, imported radios «push-to-talk» for police and taxis. During the 1960s, the mobile phone system was introduced where end users could communicate simultaneously. The first communication satellite, Telstar, was launched into the earth orbit in 1960. After the first launch, some other satellites were launched during the decade. In 1968, the parent of the current internet, ARPANET, developed by DARPA. In the late 1970s, the first commercially automated cellular network (1G generation) was launched by Nippon Telegraph and Telephone in Tokyo, Japan. In 1980s, TCP/IP was introduced as the official protocol for ARPANET.

In the 1990s, the joint development of Bluetooth technology announced by electronic companies such as Intel, Nokia, Ericsson and IBM. In 1997, a committee called 802.11 was set up and a Wi-Fi network for costumers was launched. When setting up WLAN, IEEE 802.11 standards used. Until 2000, 802.11 based networks were in popular demand. The growing demand for the 802.11 network required a more secure security than WEP.

## 1.2 IEEE 802.11 ARCHITECTURE

### 1.2.1 STATION

Stations (STAs) are all devices that form a network and operating according to the IEEE 802.11 specification. The STA are the clients of the wireless/wired network such smartphones/laptops/tablets. They can be mobile or fixed. In this thesis, STA, node, user, originator, transmitter, receiver, or client could be used alternatively and refer to the same term of station. [3]

### 1.2.2 ACCESS POINT

An access point (AP) is a specific type of Wi-Fi node. The most important function is to bridge the wireless network with the wired one. It also manages the transmissions between stations belonging to the same network. [3]

### 1.2.3 WIRELESS MEDIUM

A wireless medium used to transport all transmissions within a network to the Wi-Fi specifications. Several physical layers (wireless mediums) are specified in the IEEE 802.11 standard to support the IEEE 802.11 MAC layer.

### 1.3 ARCHITECTURES

The design of any wireless network is based on the basic service set (BSS). BSS shows the grouping of certain stations in a specific way in order to communicate with each other. Joining a BSS is generally mandatory to all stations to connect while operating to the same IEEE 802.11 specifications. There are two basic types of BSS:

- a) Independent BSS (IBSS)
- b) Infrastructure BSS.

Many BSS infrastructures can form an extended BSS (ESS). These different architectures are shown in Figure 3.

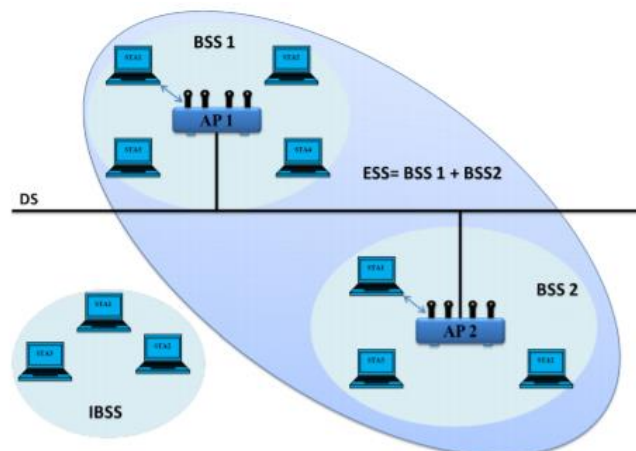

FIGURE 3 : IEEE 802.11 ARCHITECTURES

Each BSS has a unique identifier 48-bit referred to as the BSS identifier (BSSID). This BSSID is used as a network address to be used for connection link between different BSSs. Most often, the AP MAC address is used as the BSSID of the BSS. Similarly, a BSS has a service set identifier (SSID) that identifies the BSS. Now we will see the different architectures BSS.[3]

- **Infrastructure BSS:** In infrastructure mode, all stations are connected to an AP that manages all BSS exchanges. The IEEE 802.11 defines so that each station is associated with a single AP. The latter connects directly to the DS and provides network services for stations located in the Basic Service Area (BSA). The operating network parameters are fixed.

- **Independent BSS:** Stations with IBSS architecture operate autonomously and do not need an AP for transmissions management. The stations create a direct connection between them without any retransmission point. A station from the IBSS, defined as the group owner (GO), undertakes the network configuration. This type of architecture is generally designed for a small number of users who want to communicate in a short time. IBSS is sometimes referred to as ad-hoc BSS.
- **Extended BSS:** A BSS team can be an ESS, allowing stations in the BSSs to communicate together and be easily moved between different BSAs. APs act as bridges not only to their relevant STAs but also to other APs belonging to the same ESS. It is one of the most used architectures (particularly in companies) as it offers the possibility to create communications between station regardless of their location in the ESS. [4]

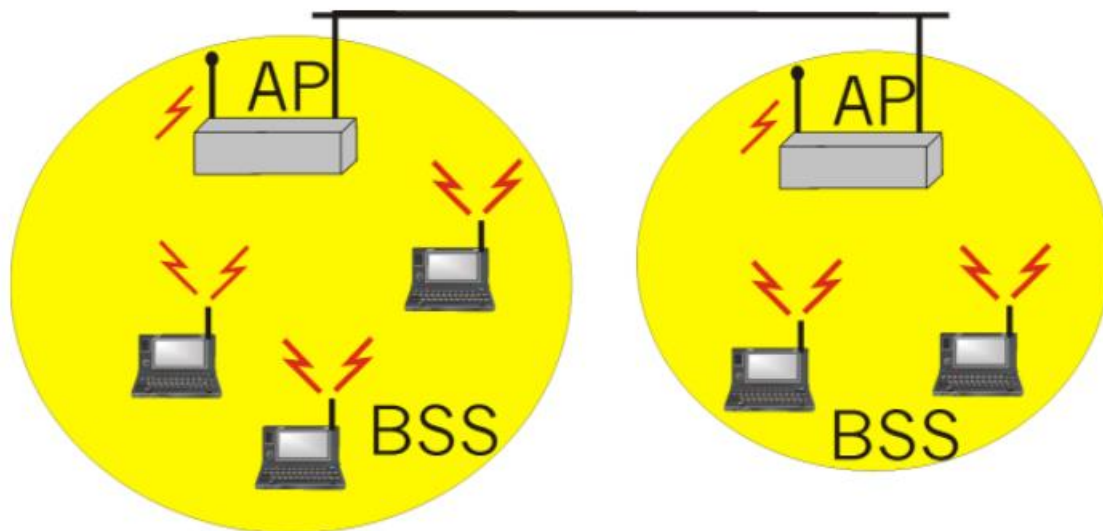
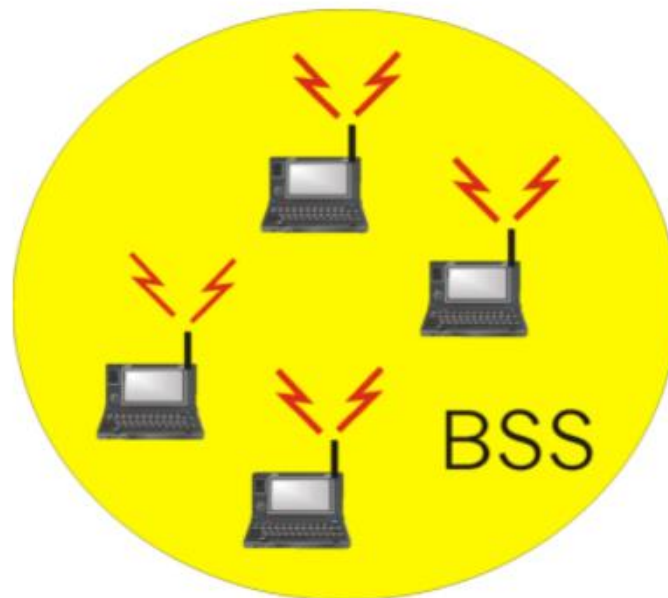

FIGURE 4 : IEEE 802.11 LAN ARCHITECTURE

Figure 4 illustrates the main elements of the 802.11 wireless LAN architecture. The basic building block of the 802.11 is as the basic service suite (BSS) in 802.11. A BSS typically contains one or more wireless stations and a central base station known as an Access Point (AP). The stations, which can be fixed or mobile and the main base station communicate with each other using the IEEE 802.11 wireless MAC protocol. Many AP can be connected to each other using an ethernet or a wireless channel to form , so it called distribution system (DS). DS is in upper levels protocols (like IP) as a single 802 network.[5]



**FIGURE 5 : IEEE 802.11 AD HOC NETWORK**

Figure 5 shows that IEEE 802.11 stations can also be grouped to create an ad hoc network, a network without central control and without connections on the outside world. An ad hoc network can be created when people with laptops meet in a meeting room and want to share data with no central AP. There has been a huge recent increase in interest in ad hoc networking as mobile communication continues to grow rapidly.[5]

#### **1.4 EVOLUTION OF THE STANDARD 802.11**

In 1997 the first Wi-Fi standard was introduced with the original protocol 802.11 only one MAC sublayer and three PHY layers (IR, FHSS and DSSS) and at 1 and 2 Mbps in the ISM band were available. Two years later in 1999, it had already prepared 802.11b allowing speeds of 5.5 and 11 Mbps using DSSS also to reduce interference and 802.11.[6]

At that moment, companies began using wireless networks as a standard part of operation, because of the reasonable prices, ready to install 802.11b networks, and data throughput at 11 Mbps. In the physical layer use Direct Sequence Spread Spectrum (DSSS). It operates in ISM band – 2.4GHz and a single channel at 20Mhz. This standard offer low modulation, only QPSK. These features provide a throughput at 11Mbps.

As a result, 802.11b eventually dominated the business market for wireless, intra-office & intra-plant wireless data communications.



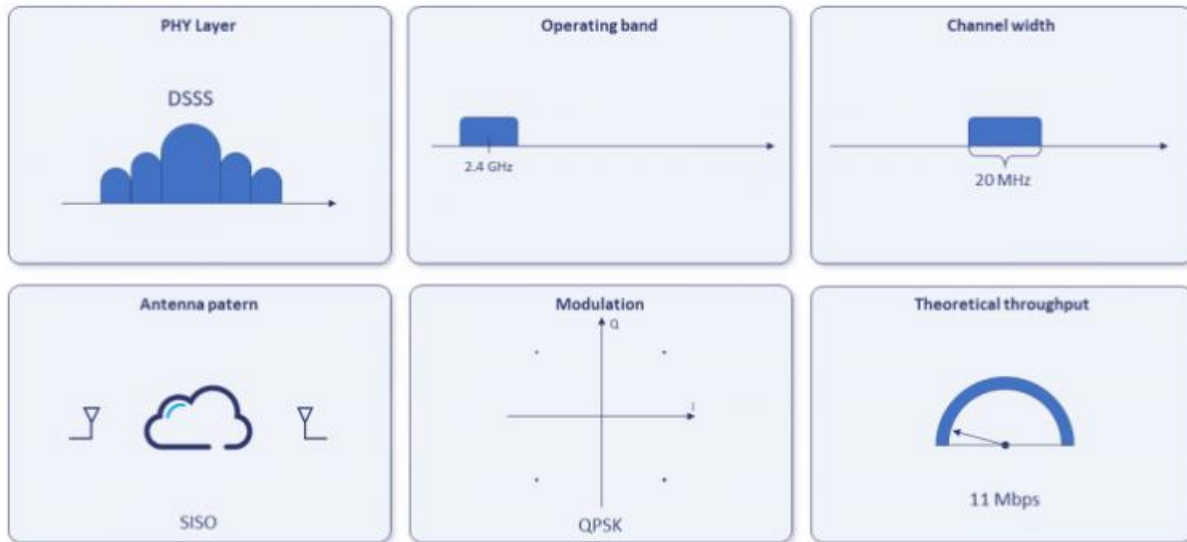

FIGURE 6 : 802.11B – FEATURES

Also, in 802.11a is used a band at 5GHz but there is a technical difficulty in production for this frequency delayed 802.11a, and that's the reason why 802.11b became more popular and more familiar. 802.11a used higher modulation order and OFDM , offer throughput up to 54Mbps.[6]

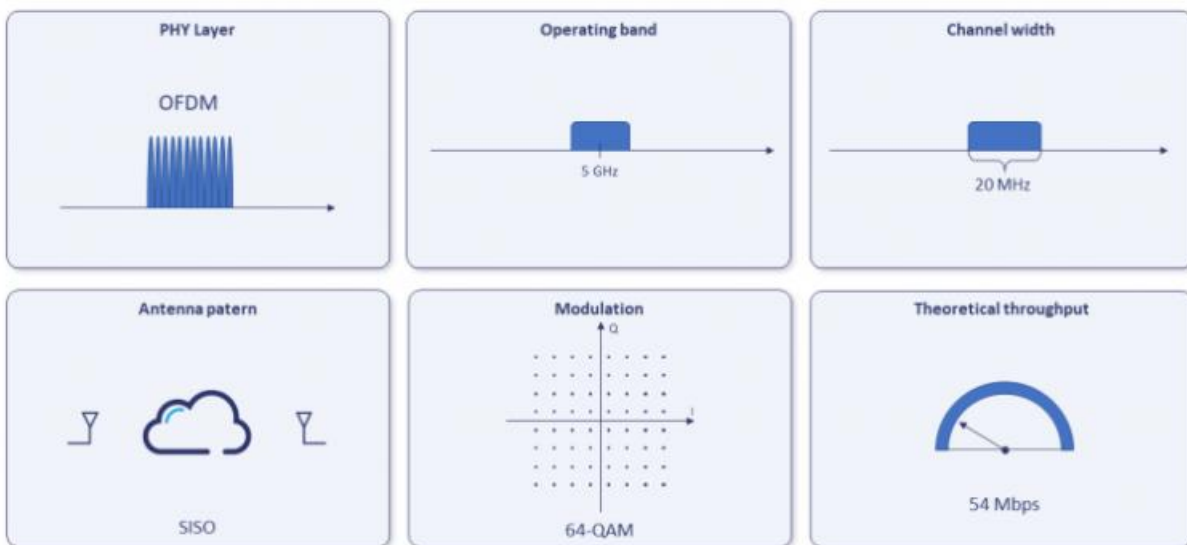

FIGURE 7 : 802.11A – FEATURES

It seems that due to the interoperability that 802.11 products suffered and their objective as a non-profit organization is not only to certify all 802.11-of all products for interoperability (providing them with the logo shown in Figure 8 but also to promoting Wi-Fi technology :

“Connecting everyone and everything, everywhere”



FIGURE 8 : WIFI CERTIFIED LOGO

The creation of the Wi-Fi Alliance together with the setting of the 5 GHz band in some countries helped the 802.11a to be born simultaneously. Due to the new features by this frequency band offered this new standard offered speeds until 54 Mbps using the new OFDM technique. When they discovered how useful it could be to apply OFDM to the ISM band, 802.11g was validated in 2003 (using the CCK [Complementary Code Keying] technique to ensure 802.11b compatibility). [7]

However recognizing the user's need for BW and the evolution of 3G to 4G generation since the appearance of smartphones, the 802.11n (Wi-Fi 4) was released in 2007 introducing the innovative MIMO and Channel Bonding techniques (to increasing the available bandwidth and data rates) at the same time that allowing backwards compatibility with old standards.

Wi-Fi 4 operates in bands 2.4 & 5 GHz. 2.4 GHz provide larger coverage ranges, because it uses longer wavelengths (although this can be offset at 5 GHz access points and customers using additional antennas). However, 5 GHz performs better at shorter ranges, because 2.4 GHz channels look to be narrower and more crowded with connected devices. 2.4 GHz are also struggling with coexistence with other wireless technologies, such as Bluetooth.

Wi-Fi 4 has doubled the maximum channel bandwidth from 802.11b of 20 MHz. This is important, because wider bandwidths can handle more traffic.

Digital Quadrature Amplitude Modulation (QAM) transmits telecommunications data via symbols, each of which contain a given number of bits. More bits per signal means more data is transferred in a given cycle. A 64-QAM system carries 6 bits/symbol.

Multiple in Multiple out (MIMO) is a wireless technique for sending and receiving multiple radio signals on the same channel. MIMO uses multiple antennas at each end to harness this “multi-path propagation” and achieve higher overall throughput. More antennas mean higher performance. Wi-Fi 4 allowed for 4x4 MIMO, four antennas each for receiving and transmitting.

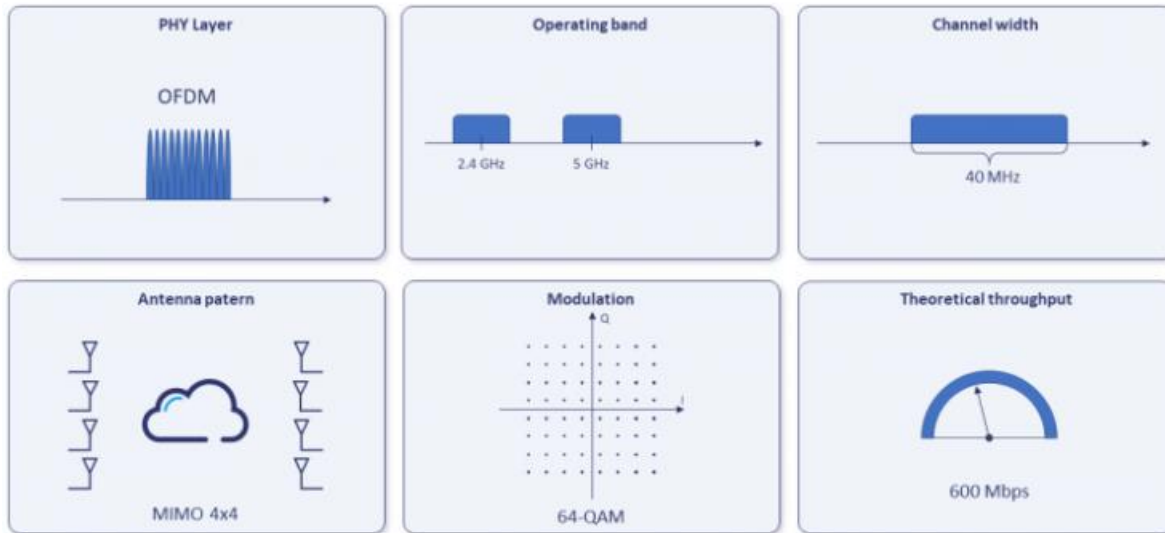

FIGURE 9 : 802.11A – FEATURES

Years later in 2013 extending the 802.11n interface concepts released 802.11ac. It was distributed with the 2.4 GHz band and used only 5 GHz. The Wi-Fi 4 used a single-user (SU) MIMO scheme. This means that a device could only transmit to one receiving device at a time.

Wi-Fi 5 switched to Multi-User (MU) MIMO, opening the door to much more efficient handling of multiple clients from a router or access point.

The Maximum channel width increased to 160 MHz and modulation to 256-QAM. The number of spatial streams doubled from four to eight (although few if any access points ever implemented more than four). The PHY rate (the bandwidth of the network adapter interface) took a huge 11x leap to 6.9 Gbps, delivering a practical MAC throughput of 4.49 Gbps, compared to 390 Mbps for Wi-Fi 4, and the beamforming also introduced.

The future looks to 802.11ax (Wi-Fi 6) in August 2019. Based on the leading specifications, the improvements over Wi-Fi 5 seem modest.

For a single user, Wi-Fi 6 is only 37% faster — with the addition of 2.4 GHz spectrum while supporting 5GHz. The Channel bandwidth exceeds 40 MHz in 2.4 GHz but reaches 160 MHz in 5 GHz. In Wi-Fi 6 enters 1024-QAM, retains support for eight spatial streams (8x8), and MU-MIMO. When maximized, Wi-Fi 6 affords maximum data rate of 9.6 Gbps.

Wi-Fi 6 introduces Orthogonal Frequency Division Multiple Access (OFDMA), a unwieldy mouthful that allows routers to divide channels into smaller radio bands called resource units (RUs).

Different RUs supply to different client devices for better support devices in environments and/or support different data streams to the same device, which can help reduce latency. The combination of OFDMA & MU-MIMO in Wi-Fi 6, which now supports multiple devices communicating in both directions, is particularly strong.

In 2021, expect Wi-Fi 6E. Wi-Fi 6E exploits the decision of the Federal Communications Commission (FCC) of April 2020 to open 1200 MHz of radio spectrum around 6 GHz for unlicensed use. This will allow another seven 160 MHz channels. Wi-Fi 6E retains all the features of Wi-Fi 6 and adds a third radio band at 6 GHz. This additional bandwidth will be more and more valuable for applications with high data rate, especially for those with high definition video data. We mentioned virtual reality, but augmented reality will also benefit. Also, service providers will offer things such as in-vehicle entertainment and high-speed device. Wi-Fi 6 enables 4K and higher video streams, with more cameras connected to fewer access points, saving on infrastructure costs.

Wi-Fi 7 (802.11be) is expected to arrive in 2024. This latest evolution could be the Gigabit Ethernet-killer you were expecting. Part of that will come from adoption of 4096-QAM and part of the ability to work across 2.4 GHz, 5 GHz, and 6 GHz, instead of switching to the best option yourself. Wi-Fi 7 will include bandwidth up to 320 MHz and 16 spatial streams. Interestingly, as the IEEE's candidate features document discusses, wider channels are not always better. But problems with very wide channels can be mitigated with simultaneous multi-band operation. All of this will more than double the maximum theoretical data rate of Wi-Fi 7 over 46 Gbps, with the expected range of real-world bandwidth up to 30 Gbps be shared across multiple devices. The Video will be a huge beneficiary. 8K video uses four times more pixels than 4K, and many people likely will need several streams delivered. Wi-Fi 7 is expected to triple the speed of Wi-Fi 6's to twice the frequency, in part due to the ability to transmit and receive simultaneously at the same frequency as well as multiple bands. Faster speeds, more devices, and lower latency. Everything that has benefited from Wi-Fi 6 and 6E is getting better in this next release.

Table 1 summarized parts of IEEE 802.11 specifications techniques that described before. [6]

IEEE 802.11 Protocol	Release Date	Frequency Bands (GHz)	BandWidth (MHz)	Modulation	Maximum Linkrate
Wi-Fi (802.11)	1997	2.4 GHz			
Wi-Fi 1 (802.11b)	1999	2.4 GHz	22	DSSS	11 Mbps
Wi-Fi 2 (802.11a)	1999	5 GHz	20	OFDM	54 Mbps
Wi-Fi 3 (802.11g)	2003	2.4 GHz	20	DSSS, OFDM	54 Mbps
Wi-Fi 4 (802.11n)	2008	2.4/5 GHz	20/40	64-QAM OFDM	1.2 Gbps
Wi-Fi 5 (802.11ac)	2012	2.4/5 GHz	20/40/80/160	256-QAM OFDM	3.5 Gbps
Wi-Fi 6 (802.11ax)	2019	2.5/5 GHz	20/40/80/160	1024-QAM OFDM	9.6 Gbps
Wi-Fi 6E (802.11ax)	2021	2.5/5/6 GHz	20/40/80/160	1024-QAM OFDM	9.6 Gbps
Wi-Fi 7 (802.11be)	2024	1-7.25 (Including 2.4 ,5, 6 GHz bands)	Up to 320	4096-QAM OFDM	46 Gbps

TABLE 1 : COMPARISON OF 802.11 NETWORKS

### 1.5 IEEE 802.11 PHYSICAL LAYER

The Physical Layer handles data transmission between nodes. IEEE 802.11 defines five different Physical Layers (different modulation techniques) [8].

- Direct Sequence Spread Spectrum (DSSS)
- Frequency Hopping Spread Spectrum (FHSS)
- Infrared (IR)
- High Rate Direct Sequence Spread Spectrum (HR/DSSS)
- Orthogonal Frequency Division Multiplexing (OFDM)

The DSSS is modulation technique where the “data” is multiplied with a Spreading Sequence (PN Sequence), much higher frequency than the data, which “spread” the signal to a wider bandwidth. 25 MHz bandwidth is used, which provides space for three different non-overlapping locations of the DSSS spectrum within the ISM band. The bit rate for this technique is 1 or 2 Mbps.

The FHSS is a modulation technique wherein the data packets are transmitted in different frequency channels accordance with a pseudo random frequency hopping scheme. The transmissions are distributed over frequency with time, thus the data is spread over a large bandwidth. In this case there are 79 channels of 1 MHz wide within the ISM band and is used hop rate of 2.5 hops per second. Also, for this technique, the bit rate is 1 or 2 Mbps.

The IR is a modulation technique where the data is sent with infrared light (wavelength 850 nm to 950 nm) and requires Line of Sight (LOS). This technique is intended for indoor use only.

HR/ DSSS occupies about the same spectrum with the DSSS and uses Complementary Code Keying (CCK) as modulation.

As the name implies, the data rate is higher than for the original DSSS , 5.5 to 11 Mbps instead of 1 to 2 Mbps. But the higher bit rates require higher SNR, which reduces the range. It is compatible with the original DSSS system.

The IEEE 802.11b standard uses this CCK modulation and operating in the ISM band. CCK modulation is based on complementary codes and was chosen over other modulations for its superior performance regarding multipath and its good autocorrelation and cross-correlation properties.

### 1.5.1 PHYSICAL LAYER (PHY) FRAME STRUCTURE

The 802.11 Physical Layer uses burst out transmissions or packets. Each packet contains a Preamble, Header and Payload Data (Figure 10). [9]

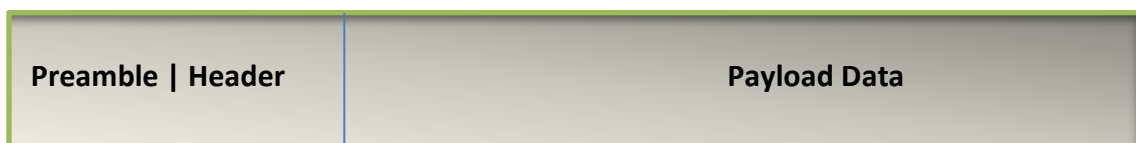

FIGURE 10 : EACH PHY PACKET CONTAINS A PREAMBLE, HEADER & PAYLOAD

The Preamble allows the receiver to receive synchronization time and frequency and evaluate channel characteristics for equation. It is a short sequence that the receivers watch to lock in the rest of the transmission. The Header provides information about the packet configuration, such as data rates, format. Finally, the Payload Data contains the user's payload data being transferred.

### 1.5.2 OPERATING PHYSICAL LAYER

The 802.11 standard specifies the use of state machines. Each machine performs one of the bellow functions:

- Carrier Sense/Clear Channel Assessment (CS/CCA)
- Transmit (Tx)
- Receive (Rx)

#### **Carrier Sense/Clear Channel Assessment (CS/CCA)**

The CS / CCA process is running while the receiver is activated, and the station is not currently receiving or transmitting a packet.

The CS / CCA process is used for two specific purposes:

To find the start of a receivable network signal (CS) and to define if the channel is clean before transmitting a packet (CCA). [9]

#### **Transmit (Tx)**

Transmit (Tx) is used to send individual octets to the data frame. The transmit process evoke by the CS/CCA process immediately in receiving a PHY-TXSTART.request (TXVECTOR) from the MAC sublayer. The CSMA/CA protocol is executing by the MAC with the PHY PLCP in the CS/CCA process before the transmission process is executed. [9]

#### **Receive (Rx)**

Receive (Rx) is used to obtain individual octets of the data frame. The receive process is called by the PLCP CS/CCA process when detecting a portion of the template synchronization pattern followed by a valid SFD and PLCP Header. Although unsightly, the preamble and PLCP header are not “received”. Only the MAC frame is “received”. [9]

## 1.6 MEDIUM ACCESS CONTROL (MAC) LAYER & KEY TECHNOLOGIES

In Medium Access Control (MAC) sublayer, includes 2 functions: Point Coordination Function (PCF) and the Distributed Coordination Function (DCF).



FIGURE 11 : MAC ARCHITECTURE

The PCF MAC is optional and operates over the DCF MAC, which is mandatory. PCF is used with APs and is very complex, while DCF is simpler and uses a respected access method known as carrier sense multiple access with collision avoidance (CSMA/CA).

The PCF is required for contention free services, while the DCF is used for contention services and basis for PCF. The architecture was well defined, and still in use in the latest version with their updates. Figure 11 shows the original architecture of MAC sublayer. [10]

### 1.6.1 DISTRIBUTED COORDINATION FUNCTION (DCF)

DCF, known as carrier sense multiple access with collision avoidance (CSMA/CA), plays an essential role in IEEE 802.11 family. Allows automatic sharing of public resources between all stations (STAs). In most cases, STA channels working on are busy and therefore contention is somehow unavoidable. In this situation, when an STA desires to start a frame exchange, will follow several basic operations. The STA shall listen to the channel and wait until it determines that the medium would be idle for longer period than a Distributed Inter Frame Spacing (DIFS). Then, the random backoff time shall be applied given the equation:

$$\text{Backoff Time} = \text{Random}() \times \text{aSlotTime} \quad (2.6.1.1)$$

Here, Random() generates a Pseudorandom integer which satisfy a uniform distribution in space [0, CW], where CW is related to the count of retries, and aSlotTime an attribute that depends on medium. [10] A backoff procedure shall be invoked if either the physical or virtual carrier sensing mechanism determines the channels are busy, or transmitting STA indicates a failed transmission.



To start the backoff procedure, STA will set its backoff timer with the formula in (2.6.1.1), and all timers will happen after a period of DIFS. When the timer appears, the STA would determine if the channel is idle for every slot time (and wait for another DIFS period). The transmission starts when timer reaches 0. Figure 12 shows all back off procedure. [10]

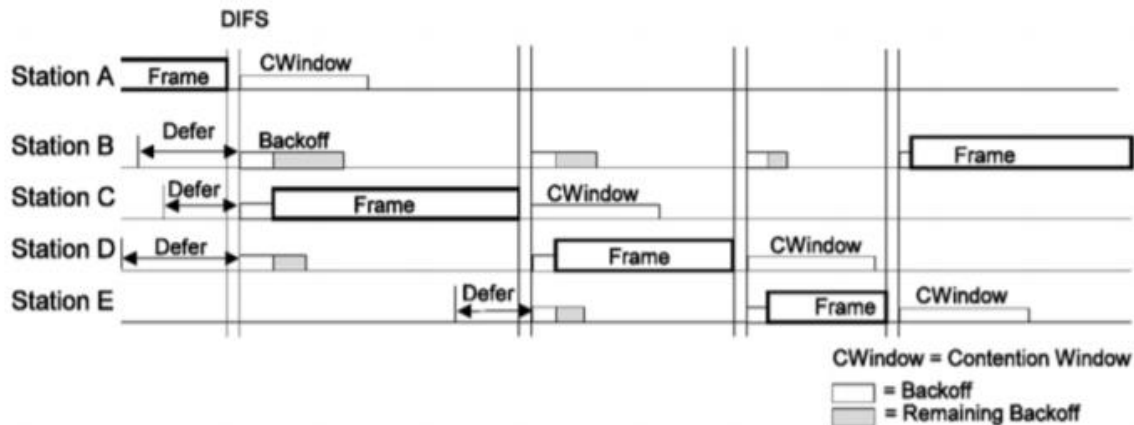

FIGURE 12 : BACK OFF PROCEDURE

The value of the backoff counter is randomly selected from a uniform distribution over the interval  $[0, CW_{i,k} - 1]$ , where  $CW_{i,k}$  is defined as the size of the contention window (CW) of a station in the  $i$ th group in the  $k$ th stage. The stage index starts at zero and is increases by 1 each time collision occurs. Hence  $CW_{i,0}$  is the size of initial CW.

Whenever a timeslot is detected idle, the backoff counter is decreases. If the slot is sensed busy at any time, the process is interrupted and restarted when an idle slot is encountered. When the counter reaches zero, the frame is transmitted.

When collision occurs, those stations involved in the collision enter into their own backoff process.

For an example of the 1<sup>st</sup> collision, the stage index increases by one, i.e.,  $k = 1$ . In addition, the size of the contention window is increased by:

$$CW_{i,k} = \begin{cases} 2^k CW_{i,0}, & 0 < k \leq k_{max,i} - 1 \\ 2^{k_{max,i}} CW_{i,0}, & k_{max,i} \leq k \leq k_{retry,i} \end{cases} \quad (1.5.1)$$

With each collision, the size of CW increases until it reaches its maximum, i.e.,  $CW_{max,i} = 2^{(k_{max,i})} CW_{i,0}$  after which it remains the same. The frame is dropped after  $k_{retry,i}$  attempts.

## 2. INTRODUCTION OF WI FI 6 (802.11AX)

When deciding how to improve the next generation wireless protocol, IEEE and Wi-Fi Alliance used a survey to ask users about the development and performance of WIFI. The results showed that as many Aps get deployed in each location (apartment buildings, university campus train stations and busy airports), congestion and interference are the main reasons of low data rate. Such sites have multiple APs and overlapping areas. To tone down this problem, IEEE and WIFI Alliance recommend that the new wireless protocol should focus on real-world scenarios rather than bandwidth, higher order MCS or MU-MIMO. [11]

When compared with 802.11ac, 802.11ax promotes the following features:

- Operates on 2.4GHz band in addition to the 5GHz.
- New OFDM symbol, provides downlink and uplink OFDMA, offers uplink MU-MIMO (up to eight clients), is characterized by 1024 Quadrature Amplitude Modulation (QAM).
- Saves customer battery life and spatial reuse (Basic Service Set Coloring [BSS color]).

Table 2 provides comparative technical information on recent Wi-Fi generations.

802.11n (2008)	802.11ac (2012)	802.11ax (2018)	Goals of the 802.11ax Project
<ul style="list-style-type: none"> <li>• 2.4 &amp; 5Ghz supported.</li> <li>• Wider Channels (40 MHz)</li> <li>• Better Modulation (64-QAM)</li> <li>• Additional streams (up to 4)</li> <li>• Beam Forming (explicit &amp; implicit)</li> <li>• Backwards compatibility with 11a/b/g</li> </ul>	<ul style="list-style-type: none"> <li>• 5Ghz only</li> <li>• Even Wider channels (80, 160Mhz)</li> <li>• Better modulation (256-QAM)</li> <li>• Additional streams (up to 8)</li> <li>• Beam Forming (explicit)</li> <li>• MU-MIMO</li> <li>• Backwards compatibility with 11a/b/g/n</li> </ul>	<ul style="list-style-type: none"> <li>• 2.4 &amp; 5Ghz supported.</li> <li>• OFDMA uplink &amp; Downlink</li> <li>• Extends and generalizes OFDM.</li> <li>• Introduces the concept of Resource Units (RU's)</li> <li>• Massive parallelism</li> <li>• Better modulation (1024-QAM)</li> <li>• Uplink MU-MIMO</li> <li>• Spatial re-use (BSS color)</li> <li>• Backwards compatibility with 11a/b/g/n/ac</li> </ul>	<ul style="list-style-type: none"> <li>• Enhance operation in 2.4 &amp; 5GHz bands (802.11ac was only 5 GHz)</li> <li>• Increase average throughput per station by at least 4x in a dense deployment scenario (802.11ac specified aggregate throughput without a specific scenario)</li> <li>• For outdoor and indoor networks</li> <li>• Scenarios include wireless corporate office, outdoor hotspot, dense residential apartments, stadiums.</li> <li>• Maintain or improve power efficiency of client devices.</li> </ul>

TABLE 2 : WI-FI STANDARDS PROGRESSION

## 2.1 CAN 802.11AX GO SO FAST?

Peak wireless speed is the product of four factors: channel bandwidth, constellation density, number of spatial streams, and overhead per-symbol. WIFI 6 enhances on constellation density by adding 1024 QAM but more significantly improves the per-symbol overhead with flexible PHY timing parameters. [12]

First, the change from 256 QAM to 1024 QAM increases maximum rates by  $10/8 = 1.25$  times. Being closer to each other, the constellation points are more sensitive to noise, so 1024 QAM helps most at shorter range. 256 QAM is more reliable, but 1024 QAM does not require any more spectrum or more antennas than 256 QAM. It can be easily applied with existing physical systems.

Second, after a fixed symbol duration ( $T_s$ ) of 3.2 microseconds ( $\mu s$ ) and only two Guard Intervals (GI) of 400 or 800ns to a longer  $T_s$  (12.8  $\mu s$ ) and three guard-interval options (0.8, 1.6, or 3.2  $\mu s$ ) allows higher speed and, more reliability, when needed. Mathematically, the  $T_s$ -to ( $GI + T_s$ ) ratio determines the peak time-domain efficiency, which for 11ac was up to  $3.2 \mu s / (3.2 \mu s + 400 \text{ ns})$  or 88.9%, whereas with 802.11ax we can achieve up to  $12.8 / (12.8 + 0.8) = 94\%$  efficiency for a peak throughput gain of 5.9 percent, and yet with much greater multipath robustness.

In addition, the 802.11ax tone plan is denser with 980 data tones (OFDMA subcarriers) per 13.6  $\mu s$  ( $T_s$  + minimum GI) over 80 MHz, whereas 802.11ac has 234 data tones (OFDM sub-carriers) per 3.6  $\mu s$  in the same 80 MHz. This increased tone density results in an additional peak throughput gain of 10 percent with respect to 802.11ac in the same spectrum (since  $(980/13.6)/(234/3.6) = 1.1$ ).

Then the speed is directly proportional to the number of spatial streams. More spatial streams require more antennas, RF connectors, and RF chains on transmitter and receiver. The antennas should be spaced  $1/3$  wavelength ( $3/4$  inch at 5.25 GHz) or more and the additional RF chains consume extra power. The physical separation requirement in particular drives most mobile devices to limit the number of antennas to one, or two. This trend is expected to remain unchanged for upcoming mobile devices capable 802.11ax.

However, for APs, these physical resource constraints are not as strict, so we expect first-wave 802.11ax access points to support up to 8 spatial streams, which is twice the maximum number provided in 802.11ac products currently available.

PHY	BW (as number of data subcarriers)	Data bits per subcarriers	Time per OFDM symbol (800ns GI)	1 SS	3 SS	4 SS	8 SS
802.11ac	234 (80MHz)	$\times 5/6 \times \log_2(256) \approx 6.67$	4 $\mu$ s	390Mbps	1.17Gbps	1.56Gbps	-
	2 x 234 (160 MHz)			= 780 Mbps	-	3.12 Gbps	-
802.11ax	980 (80MHz)	$5/6 \times \log_2(1024) \approx 8.33$	13.6 $\mu$ s	600 Mbps	1.8 Gbps	2.4 Gbps	4.8 Gbps
	2 x 980 (160 MHz)			1.2 Gbps	3.6 Gbps	4.8 Gbps	-

TABLE 3 : CALCULATING THE SPEED OF 802.11AC AND 802.11AX

## 2.2 DESIGN GOALS OF WI-FI 6

When we decided on how to improve Wi-Fi beyond the current release, 802.11ac, the IEEE and Wi-Fi Alliance surveyed Wi-Fi deployments and usage, to identify impediments to wider use and causes for dissatisfaction among user communities.

The conclusion was to move away from previous upgrades, which advanced higher data-rates under 'good' field conditions, and to focus more on real field conditions, and how to improve not only peak performance, but average and worst-case performance in real-world conditions.

These real-world conditions have changed over the years, due to the success of Wi-Fi. Access points are everywhere, even cover many outdoor spaces. In many areas, congestion has become a serious problem.

Examples include train stations and busy airports, apartments and even school and university sites. All are characterized by overlapping coverage from multiple access points, whether managed in the same network or uncoordinated, all serving multiple data hungry customer devices. Thus the IEEE and Wi-Fi Alliance wanted to improve performance for everyone, especially in in coverage overlap regions: in some places, interfering signals can be reduced by coordinating between access points, while in others, protocol enhancements make the Wi-Fi signal more resistant to interference.

But Internet service for mobile phones and computers is not the only use for Wi-Fi. The growing for Internet-of-Things (IoT) sensor market uses Wi-Fi for connectivity in many places, but some limitations have limited its adoption. So new features in 802.11ax allow efficient allocation of low data-rate connections, improve the battery life of IoT sensors, and extend the range of Wi-Fi signals.

Wi-Fi is also used by wireless Internet service providers (WISPs) and for outdoor point-to-point links, and here 802.11ax includes features to extend range, increasing data rates and reducing interference.

[13]

## 2.3 NEW FEATURES IN WI-FI 6

1. Downlink and Uplink OFDMA	2. Downlink* and uplink multi-user MIMO	3. Higher order modulation
4. Advanced OFDM and codin	5. Outdoor operation	6. Reduced power consumption
7. Spatial re-use	8. Transmit beamforming*	9. Single-user operation*

TABLE 4 : 802.11AX MAJOR FEATURES

\* *not new in 802.11ax*

- Downlink and Uplink OFDMA:** The OFDMA is one of the more complex features in 802.11ax. It allows a single transmission (for OFDMA downlink, the access point transmits) be separated by frequency within a channel, so that different frames addressed to different client devices using groups of subcarriers. Uplink OFDMA is equivalent to downlink OFDMA, but in this case several customer devices transmit at the same time, on different groups of subcarriers within the same channel. The uplink OFDMA is more difficult to manage than the downlink, as many different clients must be coordinated: the access point transmits trigger frames to indicate which subchannels each client can use.
- Downlink and uplink multi-user MIMO:** The downlink version extends an existing 802.11ac feature where an access point specifies that multipath conditions allow it to send, in a single time-interval, frames to different client devices. 802.11ax increases the size of MU-MIMO downlink groups, allowing for more efficient operation. Uplink multi-user MIMO is a new addition to 802.11ax, but was postponed to wave 2: like the OFDMA uplink, the access point must coordinate the simultaneous transmissions of multiple clients.
- Transmit Beamforming:** This is another feature where an access point uses a number of transmit antennas to land a local maximum signal to the antenna's receiver. Improves data-rates and extends range.

- **Higher-Order Modulation:** 802.11a/g introduced 64-QAM, and 802.11ac 256 QAM: in 802.11ax, the highest-order modulation extends to 1024-QAM. This increases peak data-rates under favorable conditions (high SNR). OFDM symbols, subcarrier spacing and FFT size have been changed to allow efficient operation of small OFDMA subchannels: these changes allow an increase in the length of guard interval without losing the symbol efficiency.
- **Outdoor Operation:** Some features improve outdoor performance. Most importantly is a new packet format where the most sensitive field is now repeated for robustness. Other features that contribute to better outdoor operation include longer guard intervals and redundancy features that allow for error recovery.
- **Reduced Power Consumption:** Existing power-save modes are complemented by new mechanisms that allow longer sleep intervals and scheduled wake up times. Also, for IoT devices, a 20MHz-channel-only mode is introduced, allowing simpler, less powerful chips that support only that mode.
- **Spatial re-use:** When claiming for a transmit opportunity, it allows a device transmitting over the top of a distant transmission, which would previously have forced it to wait. This increases network capacity by allowing more simultaneous transmissions in a given geographical area. Historically, the new features in 802.11ax are mostly extensions or improvements on previous work – with the exceptions of OFDMA and spatial re-use. [14]

## 2.4 OVERVIEW OF WI-FI 6

The WIFI 6 (802.11ax) can use 160MHz channel width which is much higher than that of Wi-Fi 5 which is 80Mhz channel width. The user can experience better speed and latency by using 160Mhz channel width, which is one of the main reasons why users would choose WIFI 6.

WIFI 6 also has better security in Wi-Fi Protected Access 3 (WPA3) which is the next generation of Wi-Fi security. Security WPA 3 has features such as the use of latest security method, ease of use, confidential secret. There are two types of WPA3 security, both personal and enterprise. The WPA3 is more secure than personal. Security protocols for WPA3 enterprise are stronger than any other WPA family security protocol.

WIFI 6 also uses both 1024-QAM to supply a signal packed with more data (giving you more efficiency) and a 160 MHz Channel to provide a wider channel to make your WIFI faster. Experience VR without stutter or enjoy amazing 4K and even 8K streaming. WIFI 6 uses 8x8 uplink/downlink, MU-MIMO, OFDMA, and BSS Color to provide up to 4x more capacity and to handle more devices. [15]

	802.11ac	802.11ax
<b>Bands</b>	5 GHz only	2.4 GHz and 5GHz
<b>Channels</b>	20,40,80, 80+80, 160MHz	20,40,80, 80+80, 160MHz
<b>FFT Sizes</b>	64, 128 ,256, 512	256, 512, 1024, 2048
<b>Subcarrier spacing</b>	312.5 kHz	78.125kHz
<b>OFDM symbols</b>	3.2 usec	12.8 usec
<b>OFDM symbol cyclic prefix</b>	0.8 or 04 usec	0.8 or 1.6 or 3.2 usec
<b>Highest modulation</b>	256 QAM	1024 QAM
<b>Spatial streams</b>	1-8 (not implemented beyond 4)	1-8 (may be implemented)

TABLE 5 : OFDM CHARACTERISTICS FROM 802.11AC TO 802.11AX

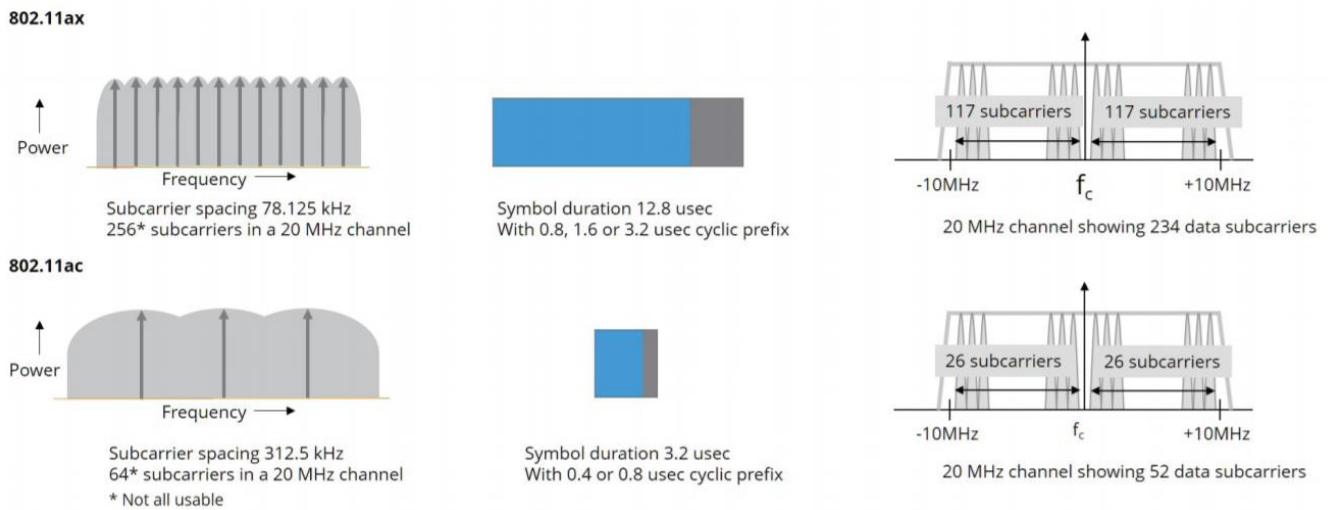

FIGURE 13 : OFDM SYMBOL DURATION & SUBCARRIERS

## 2.5 PHYSICAL ENHANCEMENTS OVERVIEW OF 802.11AX

The developing of PHY technology is always an essential part of the evolution of wireless networks. IEEE 802.11ax introduces several PHY enhancement technologies, which enable the IEEE 802.11ax to achieve a higher transmission rate of up to 9.6 Gbps, as shown in Figure 14 [16].

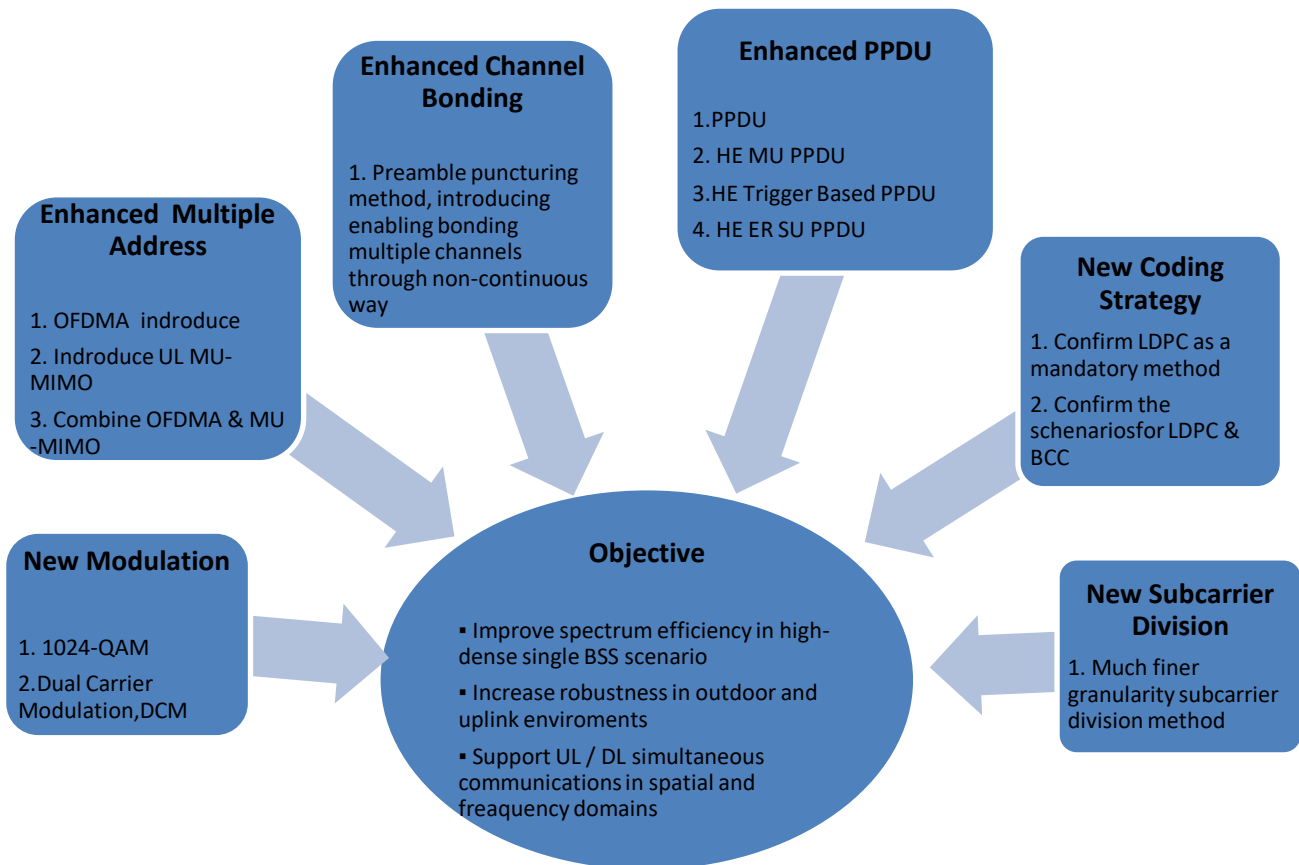

FIGURE 14 : OVERVIEW OF WI-FI 6 TECHNICAL FEATURES



### 2.5.1 NEW MODULATION TECHNOLOGY

The highest order modulation of IEEE 802.11ac is 256-QAM, so a, one modulation symbol may have 8 bits. By improving the processing of the device capability and the demodulation algorithm, to further improve the maximum transmission rate, IEEE 802.11ax introduces higher order modulation: **1024-QAM**.

In this case, a symbol carries 10 bits. Therefore, by introducing 1024-QAM, IEEE 802.11ax can achieve a 25% gain in the theoretical maximum transmission rate compared to IEEE 802.11ac in the high SINR range. Besides the adoption of a more detailed (four times of 802.11a/g/n/ac) subcarrier division as well as the new designed guard interval (GI), IEEE 802.11ax achieves a maximum transmission rate of 9607.8 Mbps or 9.6Gbps.

To enhance SNR and transmission robustness, IEEE 802.11ax introduces Dual Sub-Carrier Modulation (DCM), allowing the information modulated in a pair of subcarriers. In DCM, to reduce the peak-to-average power ratio (PAPR), the same information needs to be rotated on a pair of subcarriers:

$$S_{k + N_{SD}/2} = S_k e^{j\left(k + \frac{N_{SD}}{2}\right)\pi}, \quad k = 0, 1, \dots, (N_{SD}/2) - 1, \quad (2.5.1)$$

in which NSD indicates the number of subcarriers contained in the RU or the number of subcarriers populated in the bandwidth. It is worth noting that DCM is valid for any type of OFDMA and OFDM transmission, while IEEE 802.11ax requires that it can only be used in MCS 0, MCS 1, MCS 3, and MCS 4, and the maximum space stream number is two. This is because DCM is designed for high reliability, not high throughput. The SINR requirement of the receiving node is significantly reduced by using DCM. For example, when DCM is adopted with MCS 0, the bit error performance will be improved by 3.5 dB. Therefore, DCM benefits the robustness of outdoor scenario and UL transmission, and reduces the packet loss rate.

#### 1024-QAM Modulation

The next big performance improvement is a jump from 256-QAM to 1024-QAM. When a wireless device transmits a message, it must send an analog signal since there is no direct way to transmit binary data. This analog signal has two parts known as the amplitude (how powerful the signal is) and the quadrature (how much the signal is shifted from a reference point). By controlling the quadrature and amplitude, we can effectively transmit digital data by analog signal.

The 256-QAM system used in 802.11ac divides both the amplitude and quadrature into 16 predefined levels. This gives a total of 256 (16x16) possible transmission rates and permits up to 8 bits per transmission ( $2^8 = 256$ ). Transmitter and receiver technology have advanced greatly since the introduction of 802.11ac, so we are now able to assign more precise values to transmissions. Instead of dividing the quadrature and amplitude of a transmission into 16 possible values, 802.11ax can split it into up to 32 levels. This gives us 1024 (32\*32) possible transmission rates and up to 10 bits per transmission.

Of course, as we gather more and more data into the same limited number of resources, our sensitivity and accuracy must also increase. A small error in the reception of a 256-QAM signal may not cause a problem, but since 1024-QAM packs symbols much closer, the same error may cause an wrong value to be decoded. Devices are smart enough to know that if many transmissions are decoded incorrectly, they will have to be downgraded. [17]

1024-QAM can result in a theoretical single-stream data rate of 600Mb/s using an 80MHz channel which is 39% better than the theoretical 433Mb/s single-stream data rate of Wi-Fi 5.

**11ac – 256QAM**  
**8bits / symbol**

**11ax – 1024 QAM**  
**10 bits / symbol**

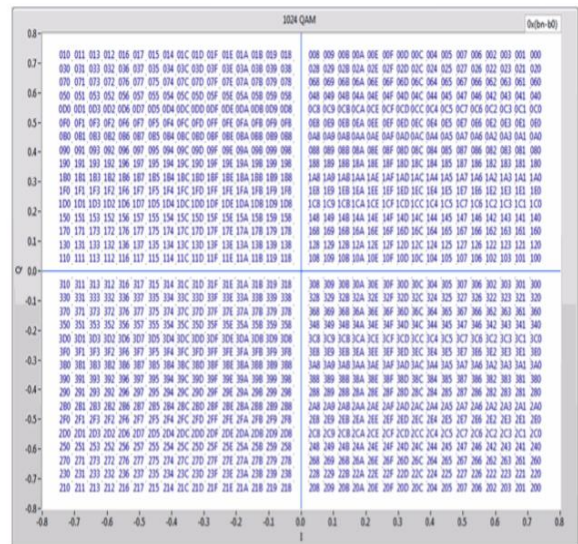
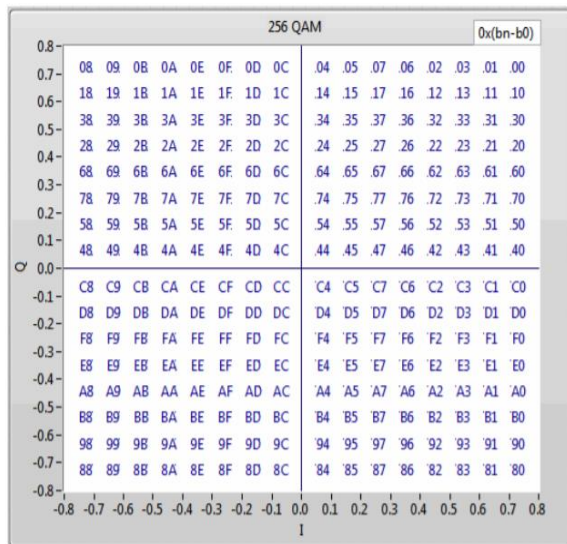
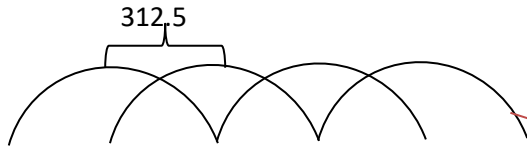

FIGURE 15 : PHYSICAL DATA RATE

Longer OFDM Symbols - increases the duration that an OFDM symbol is transmitted from 3.2us on Wi-Fi 5 to 12.8us on Wi-Fi 6 and supports a longer cyclic prefix for each symbol. A cyclic prefix (CP) that adds a portion of the end of a OFDM symbol to the front of the payload to provide a guard interval versus intersymbol interference and to improve robustness as this portion can be used if necessary. This pattern can be configured according to the general requirements (a longer CP repeats more data and occupies more space in a symbol, resulting in a lower data rate) [17].

**Long OFDM Symbol**



kHz

11n/ac  
11a/g/n/ac

- The OFDM FFT size for 20 MHz for 802.11a/g/n/ac is 64 (for 17+ years)

- 802.11a guard interval is 0.8msec, which decreased in 802.11n with the short guard interval for shorter indoor environments

- 802.11ax is adding

- 1.6 and 3.2msec guard interval for outdoor

- OFDMA, whereby users get assigned smaller sections of the channel bandwidth (resource units)

-256pt FFT enables

-4x longer OFDM symbol for more efficient symbol time (even with longer guard intervals)

- Narrower and 4x more subcarriers to allow for finer granularity of OFDMA resource units

- More efficient utilization of the data subcarriers

	802.11a/g	802.11n/ac	802.11ax
FFT size in 20 Mhz	64	64	256
Subcarrier frequency spacing	20Mhz/64 =312.5 kHz	20Mhz/64 =312.5 kHz	20Mhz/256=78.125 kHz
# of data subcarriers	48	52	234
Efficiency	75%	81%	91%
OFDM symbol	1/312.5kHz =3.2msec	1/312.5kHz =3.2msec	1/78.125kHz= 12.8 msec
Guard Interval	0.8 usec	0.8, 0.4 usec	0.8, 1.6, 3.2 usec
Symbol Time	4.0 usec	4.0, 3.6 usec	13.6, 14.4, 16.0 usec
Efficiency	80%	80%, 89%	94%, 89%, 80%

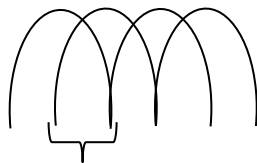

78.125 kHz

### 2.5.2 NEW CODING STRATEGY

LDPC (Low Density Parity Check) is an optional coding technology in IEEE 802.11ac however, it achieves higher gain than BCC (Binary Convolutional Coding) with the long code word length. Therefore, both LDPC with BCC are considered mandatory technologies in IEEE 802.11ax in different cases.

BCC is mandatory while LDPC is optional for traditional IEEE 802.11 IEEE 802.11ax requires both BCC and LDPC to be the mandatory coding technologies, but the application scenarios of them are strictly discrete. When the transmission bandwidth is less than or equal to 20 MHz, the use BCC is required. Otherwise, LDPC required when the transmission bandwidth is more than 20 MHz. The reason is that larger bandwidth, higher modulation order, and finer detail of subcarriers results in an increase of transmission rate. In other words, the receiver takes longer to process the received data.

However, an interleaver is required in the BCC encoding and decoding process. This means that the signal must be entered with filling bits. Therefore, the receiver must handle all the bits and cannot guarantee obtaining the sufficient transceiver conversion time. As a result, the BCC code is not suitable for the larger bandwidth.

### 2.5.3 NEW MECHANISM SUBCARRIER DIVISION

For traditional IEEE 802.11a/g/n/ac, the 20 MHz bandwidth is divided into 64 subcarriers, and the subcarrier interval is  $20,000 / 64 = 312.5$  KHz.

The number of subcarriers in IEEE 802.11ax is four times larger that of the legacy IEEE 802.11. In this case, the 20 MHz band is divided into 256 sub-carriers, and the bandwidth of each sub-carrier is reduced to 78.125 KHz.

As shown in Figure 16, taking as an example IEEE 802.11a/g, the 64 subcarriers consist of 52 populated subcarriers, one direct current (DC) subcarrier, and 11 sideband subcarriers. Furthermore, the populated subcarriers consist of 48 data subcarriers and four pilot sub-carriers. Since the subcarrier interval is 312.5KHz, the duration of one OFDM symbol is 3.2us, added to the GI 0.8us, therefore, the length of a full OFDM symbol is 4us.

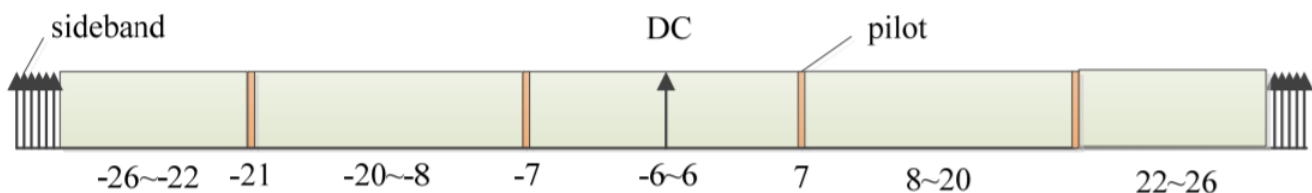

FIGURE 16 : SUBCARRIER DIVISION OF THE TRADITIONAL IEEE 802.11

To achieve more accurate and efficient scheduling for OFDMA resources and improve the spectrum efficiency, IEEE 802.11ax proposes a much finer-grained subcarrier division. As shown in Figure 17, the 20 MHz bandwidth is divided into 256 subcarriers and consequently, the interval of subcarrier is reduced to 78.125KHz.

The 256 subcarriers consist of 242 populated subcarriers, 11 sideband subcarriers, and 3 DC subcarriers. In addition, the populated subcarriers consist of 234 data subcarriers and eight pilot subcarriers. Since the subcarrier interval is 78.125KHz, the OFDM symbol length of IEEE 802.11ax is 12.8 us. The GI can be selected from 0.8us, 1.6us, and 3.2us. Accordingly, considering the overhead caused by GI, the spectrum utilization efficiency of IEEE 802.11ax increased from  $3.2 / (3.2 + 0.8) = 0.8$  at the highest  $12.8 / (12.8 + 0.8) = 0.94$ .

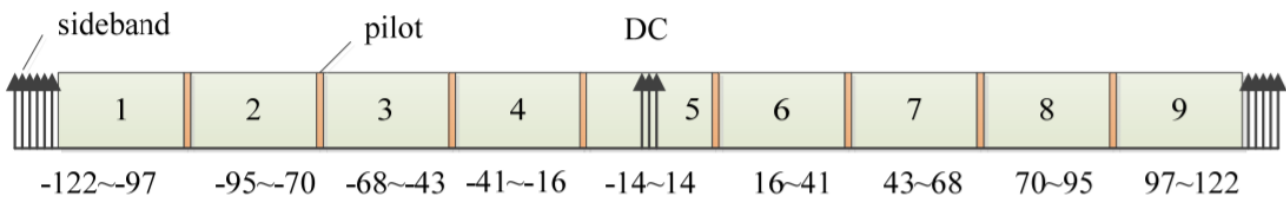

FIGURE 17 : SUBCARRIER DIVISION OF IEEE 802.11AX

#### 2.5.4 ENHANCED MULTIPLE ACCESS TECHNOLOGY

Enabling parallel transmission, OFDMA reduces the overhead and collision, and further improves spectrum efficiency.

DL MU-MIMO is adopted by IEEE 802.11ac, 802.11ax further introduces UL MU-MIMO to ensure symmetrical high performance for both DL and UL IEEE 802.11ax allows up to eight STAs to transmit simultaneously by MU-MIMO.

In addition, MU-MIMO and OFDMA are allowed to work together, i.e., multiple STAs can simultaneously send or receive frames in the same RU by MU-MIMO, which further increases transmission efficiency.

2.5.4.1 OFDMA

OFDMA belongs to the frequency domain multi-access technology, dividing the channel(s) into multiple RUs with either the same or different bandwidth, where multiple OFDM subcarriers are combined into one RU. Each RU is assigned to a specific STA for sending or receiving frames. Thus, OFDMA possesses the advantages of both OFDM and FDMA. Multi-user diversity gain can be achieved by assigning appropriate RUs for different STAs. Therefore, to improve the efficiency of MU access to the high-dense deployment scenario, IEEE 802.11ax introduces OFDMA technology. It is worth noting that IEEE 802.11ax is the first IEEE 802.11 standard amendment to introduce OFDMA.

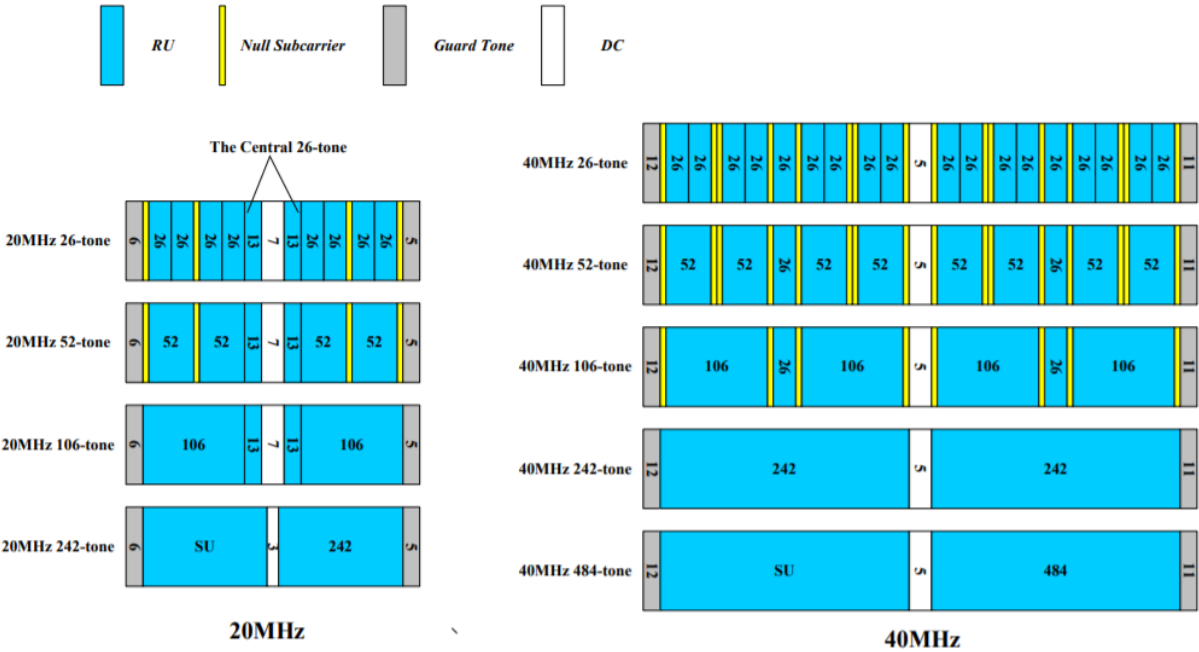

FIGURE 18A: RU DIVISION FOR IEEE 802.11AX

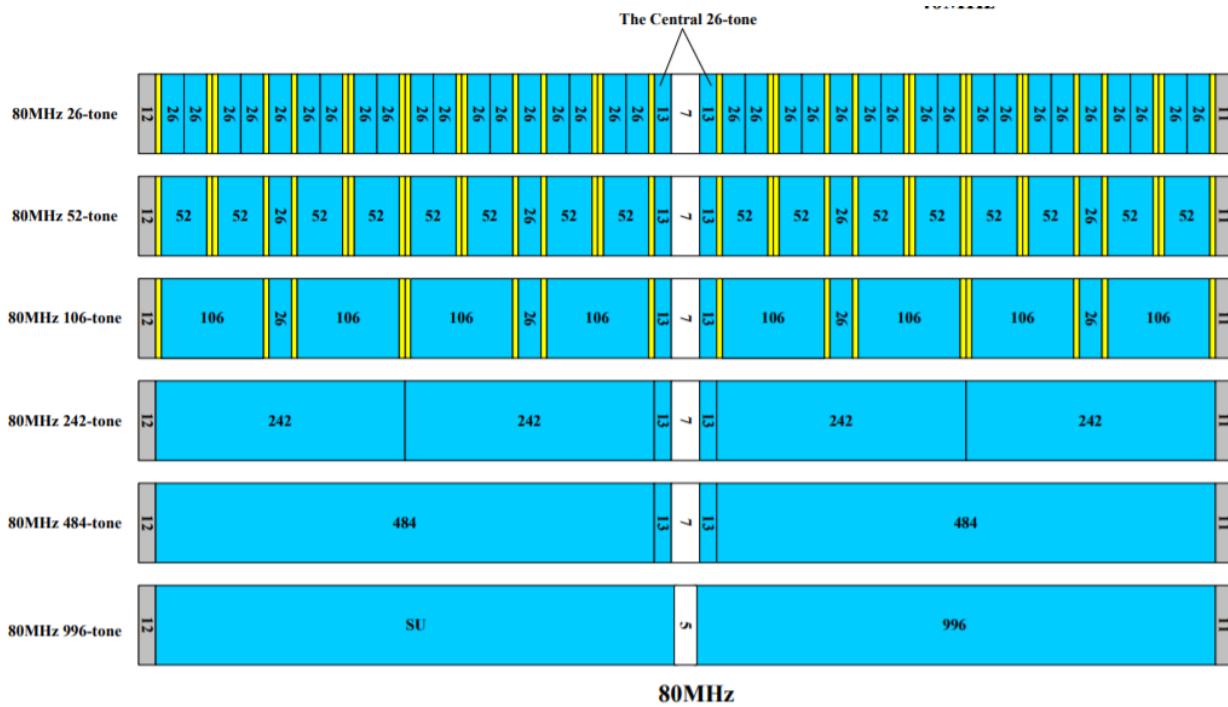

FIGURE 19 : RU DIVISION FOR IEEE 802.11AX

To simplify the resource scheduling for OFDMA, IEEE 802.11ax divides 20 MHz, 40 MHz, 80 MHz, and 160 MHz bandwidth into RUs with different sizes, and each STA sends or receives frames in a single RU. There are seven types of RUs specified in IEEE 802.11ax: 26-tone RU, 52-tone RU, 106-tone RU, 242-tone RU, 484-tone RU, 996-tone RU, and 2\*996-tone RU.

Obviously, the 484-tone RU only appears in the BW of 40 MHz, 80 MHz, and 160 MHz, 996-tone RU only appears in the BW of 80 MHz and 160 MHz, and 2\*996-tone RU only appears in the BW of 160 (80+80) MHz. Figure 19 shows the RUs division mode for 20 MHz, 40 MHz, 80 MHz, and 160 (80+80) MHz.

The difference between OFDM and OFDMA is seen in Figure 20 as follows (OFDM and OFDMA concepts). Like OFDM, OFDMA uses the multiple subcarriers, but the subcarriers are divided into several groups. Each group is referred to as an RU (Resource Unit). With OFDMA, can be applied to different transmit powers to different RUs. In this way, the efficiency of the network can be increased for many users. [18].

Think of the frustration you feel when there are many people in front of you and you know that the wait for their orders will slow you down. OFDMA is like the introduction of mobile ordering, allowing the barista (your wireless access points) to strategically handle multiple orders simultaneously to better satisfy their customers. It's a quick way of to create a timetable of several orders simultaneously to make sure they all get their coffee time.

What is impressive about resource units is that the access point can customize the size of each unit's depending on the data load that needs to be transferred. It achieves this by quickly evaluating each device and what it's trying to perform at every data transmission opportunity, which means that continuously optimized based on the needs of your network.[17]

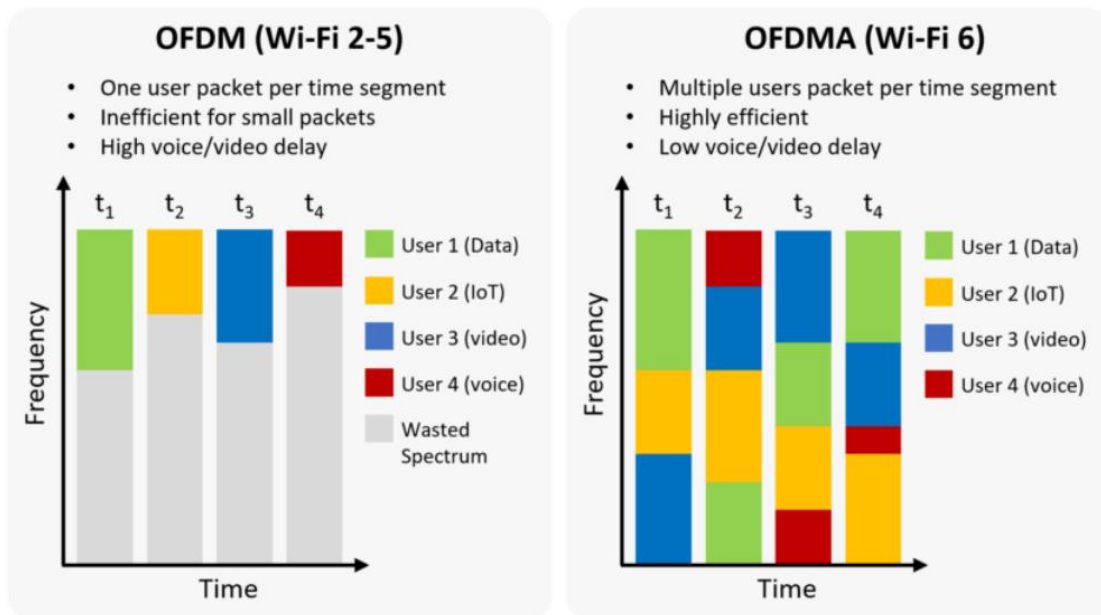

FIGURE 20: OFDM VS OFDMA



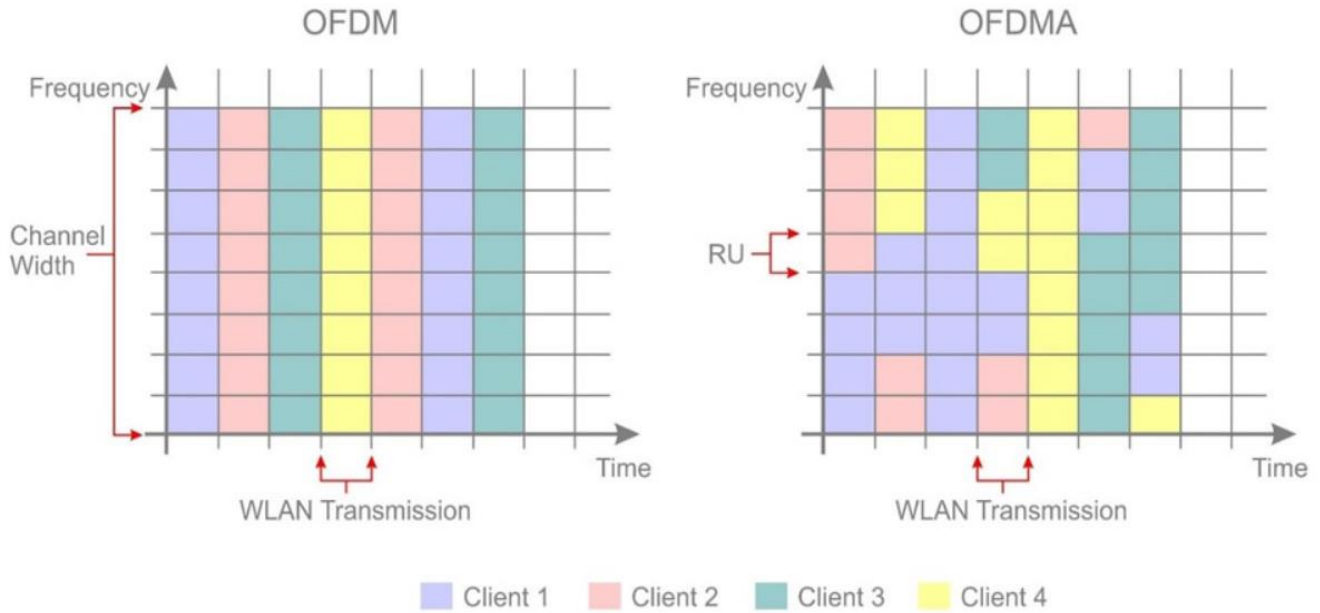

FIGURE 21 : COMPARISON BETWEEN OFDM AND OFDMA

2.5.4.2 PERFORMANCE OF OFDMA

- More active STAs achieve higher throughput gain.
- The number of active STAs restricted by delay and overhead.
- 10-20 active STAs can achieve quite good throughput gain

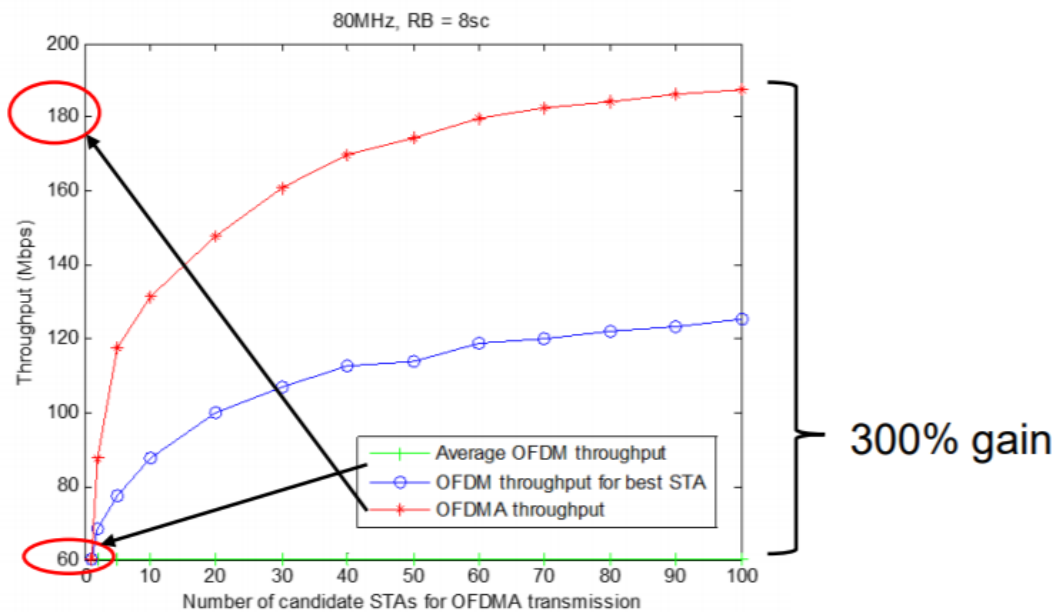

FIGURE 22 : OFDMA THROUGHPUT VS NUMBER OF STAS

### 2.5.4.3 MU-MIMO TECHNOLOGY

MU-MIMO technology uses spatial multiplexing with independent data streams on the same bandwidth, where each data stream is transmitted by multiple antennas with defined phase that leads to a constructive interference at a specific point in space, e.g. location of the receiver. Allows the AP to exchange data with multiple terminals simultaneously. Here a distinction is made between downlink MU-MIMO (DL MU-MIMO) and uplink MIMO (UL MU-MIMO).

For downlink communication, MU-MIMO has been introduced by the IEEE 802.11ac Wave 2 standard (Wi-Fi 5). Wi-Fi 6 supports DL 8x8 MU-MIMO with up to eight spatial streams by using eight antennas, resulting in a higher access capacity. A significant improvement in system view access capacity and balance of the throughput is achieved with WIFI 6 by using OFDMA technology in combination with MU-MIMO allocating different RUs to the spatial streams for multi-user multiple-access transmission. As a major innovation over previous standards, WIFI 6 also supports UL MU-MIMO technology, in which the data is transmitted on multiple spatial streams by using multiple antenna technology of the transmitter and the receiver (Figure 23).

As for downlink, WIFI 6 also supports simultaneous use of OFDMA technology and MU-MIMO for uplink. With this feature, the transmission efficiency in multi-user concurrent scenarios is improved significantly and application of delay is greatly reduced [18].

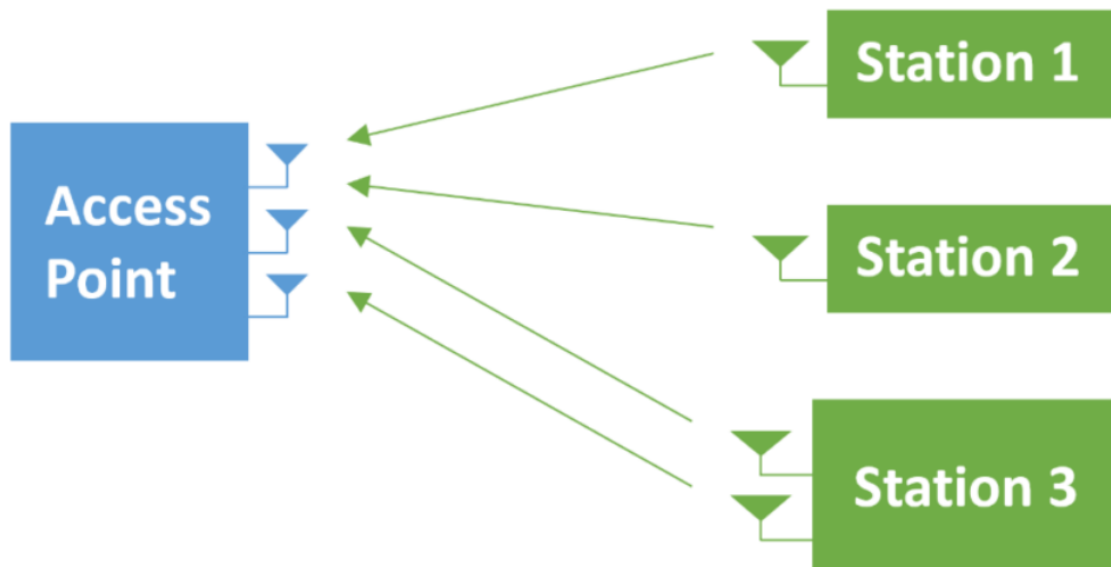

FIGURE 23 : UPLINK VIA MULTIPLE SPATIAL STREAMS WITH UL MU-MIMO

#### 2.5.4.4 OFDMA AND MU-MIMO

OFDMA does not replace MU-MIMO, and they can be difficult to differentiate from each other since both function to assist multiple network clients at the same time.

Although 802.11ax allows OFDMA & MU-MIMO to run simultaneously, these technologies are different and can operate independently from each other. The main difference is that MU-MIMO uses spatial streams to physically direct signals and separate clients while OFDMA subdivides only a single channel. Because of this, OFDMA is effective for low-bandwidth, low-demand processes like simple social media surfing or small IoT devices, MU-MIMO is preferable for high-bandwidth activities such as content streaming and heavy downloads.

OFDMA allows multiple users to subdivide the frequency bandwidth of a time segment to improve the concurrency efficiency. MU-MIMO allows multiple users to use different spatial streams to increase the throughput. Therefore, complementary and could be used depending on the type of application, as shown in Figure 24 as follows:

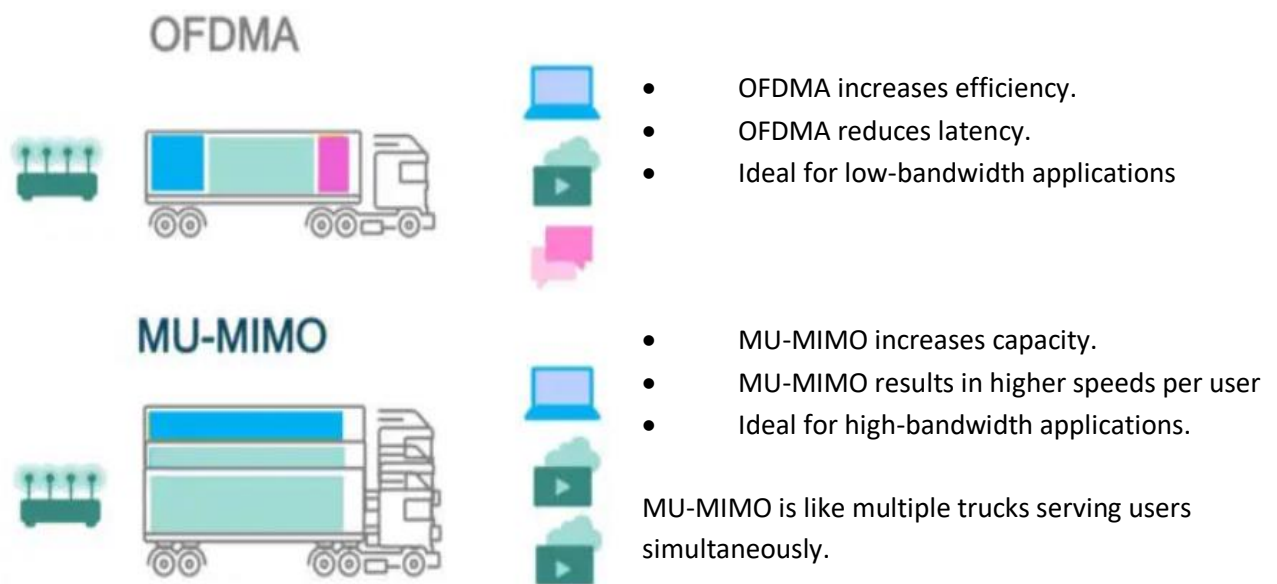

FIGURE 24 : COMPARISON OF OFDMA AND MU-MIMO

As shown in Figure 24, different users (video - web browsing - chat) can use different resource units (RUs, see truck divided by rectangles representing RUs) for communication (OFDMA). Further, a user (video) can use multiple spatial streams (see trucks on different lanes) in parallel and this can be done by many users simultaneously (MU-MIMO).

This OFDMA and MU-MIMO can work together and can be explained by taking an example: When there are eight users and four RUs, users 1-5 use RU1, and users 6-8 use RU2-RU4, respectively, and users 1-4 use different spatial streams to transmit data on the same RU1. That is, in RU1, there are four users using different spatial streams.

In this case, the OFDMA and the MU-MIMO are therefore working together [19].

### 2.5.5 CHANNEL BONDING ENHANCEMENT

Revisiting the development of IEEE 802.11, IEEE 802.11a/g using 20 MHz, IEEE 802.11n extends to 20/40 MHz, and IEEE 802.11ac supports 20/40/80/160(80+80) MHz.

The maximum bonding bandwidth gradually increased with the evolution of IEEE 802.11, and the network capacity also increased accordingly. However, except for the 80+80 MHz bonding mode, all other modes require that the channel bonded must be continuous. As a result, the larger channel bandwidth cannot be bonded when multiple idle channels are separated from the busy channel.

As shown in Figure 25, since the secondary 20 MHz is busy, even if the secondary 40 MHz is idle, AP unfortunately can only use the primary 20 MHz. This leads to serious spectrum loss. Predictably, this situation is more likely to occur for high density scenarios [20].

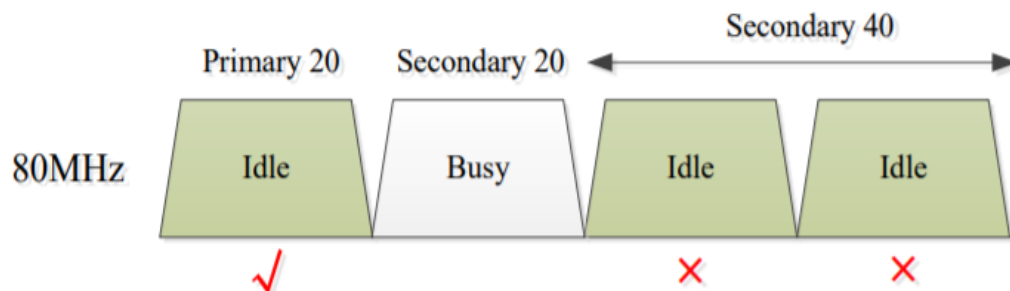
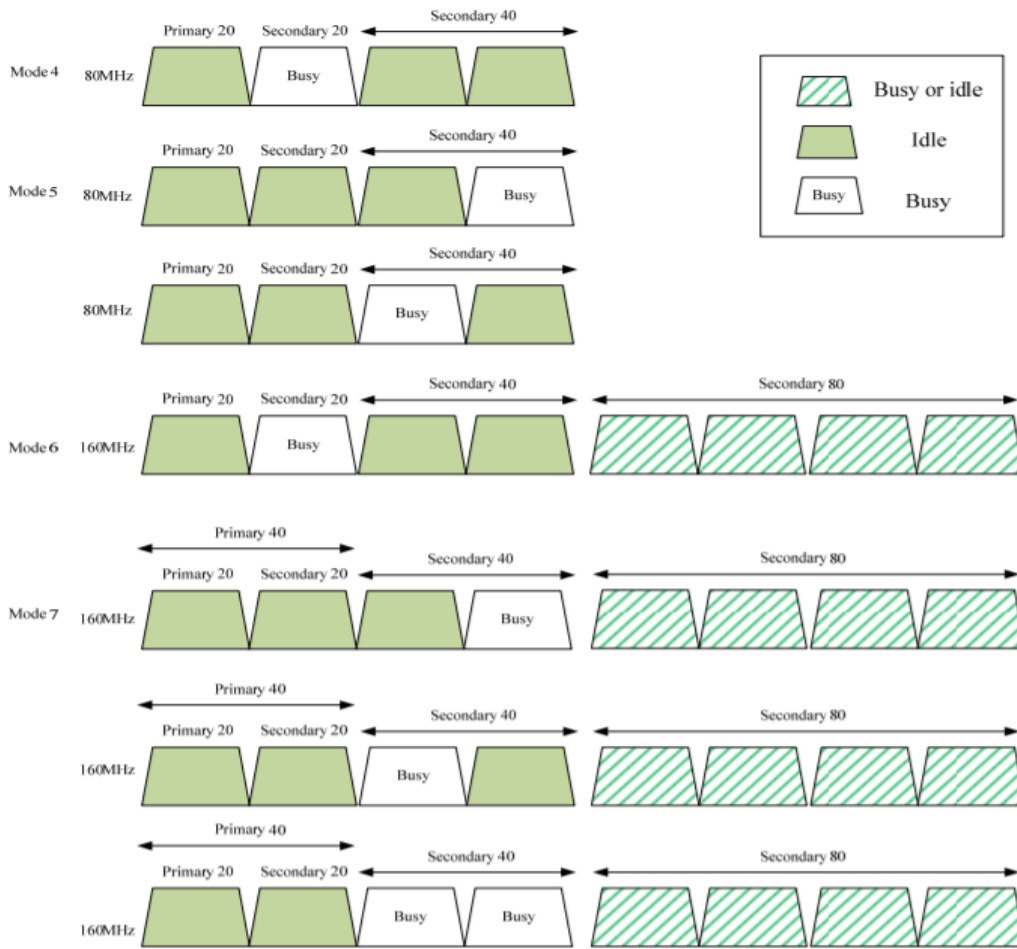

FIGURE 25 : RESOURCE WASTE CAUSED BY THE TRADITIONAL CB

To solve this problem and to further improve the spectrum efficiency, IEEE 802.11ax introduces the mechanism "preamble puncturing", thereby allowing the channel to be bonded in a non-continuous way. This increases the available bandwidth, makes Channel Bonding (CB) more flexible, and improves the transmission rate.

For the HE MU PPDU structure, IEEE 802.11ax expand by 2 bit the bandwidth field (mode 0 ~ 3). Modes 0-3 are the same as the traditional 4 modes therefore, we highlight mode 4-7 which corresponds the preamble of the puncture mechanism, as shown in Figure 26.

- Mode 4 indicates the status that the total bandwidth is 80 MHz, and the secondary 20 MHz is punctured. As shown in Figure 26, if mode 4 is to be adopted, the AP can connect 60 MHz to communicate with STA, and then the efficiency could be improved threefold.
- Mode 5 suggest that the total bandwidth is 80 MHz, and a 20 MHz in the secondary 40 MHz is punctured.
- Mode 6 indicates that the total bandwidth is 160(80+80) MHz, and the secondary 20MHz of the main 80MHz is punctured. In addition, there is no specific requirement for the secondary 80 MHz.
- Mode 7 indicates the condition that the total bandwidth is 160(80+80) MHz, and the main 40MHz of the primary 80MHz is life. In fact, there are three cases covered by mode 7, as shown in Figure 26.



**FIGURE 26 : PREAMBLE PUNCTURING MECHANISM IN IEEE 802.11AX.**

TGbe extends the preamble puncturing to 320 MHz bands and improves.802.11be enables puncturing for single user frames that is not supported in 802.11ax. This increase improves channel utilization. The exact design for puncturing is actively discussed. One topic of discussion is that Wi-Fi will operate in 6 GHz, where there are other existing technologies. To avoid them, TGbe has examined additional puncturing options. The TXOP protection mechanism was discussed for the cases of wide channel frames with puncturing.

### 2.5.6 NEW HEADERS PPDU

To support different technologies and scenarios, IEEE 802.11ax introduces four data packet structures [20].

- HE SU PPDU Format:

The single user format is the packet structure format between AP and one single STA, and between a single STA and another STA. Figure 27 shows the packet structure. Compared to IEEE 802.11ac, HE SU PPDU introduces Repeat Legacy Signal Field L-SIG (RL-SIG), which is used to enhance the robustness of L-SIG, and used to confirm a PPDU is HE format through automatic detection. Packet Extension (PE) extends the time for the receiver to process data.



FIGURE 27 : HE SU PPDU FORMAT

- HE MU PPDU Format:

The MU format enables simultaneous transmission among MUs via OFDMA and-or MU-MIMO. Based on the single user format, as shown in Figure 28, the HE-SIG-B field is added to indicate the resource allocation information for multiple users.

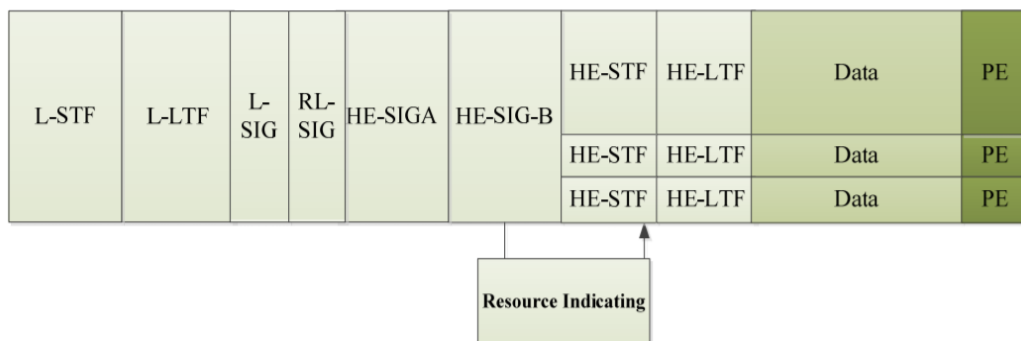

FIGURE 28 : HE MU PPDU FORMAT

- HE ER SU Format :

For improving the transmission robustness of the outdoor scenario, IEEE 802.11ax repeats the HE-SIG-A field by immediately extending two symbols to four symbols, as shown in Figure 29.

Furthermore, IEEE 802.11ax enhances the power of the traditional preamble, HE-STF and HE-LTF to further extend the transmission coverage. Finally, the transmission range of the data field can be extended via DCM narrowband RU transmission.

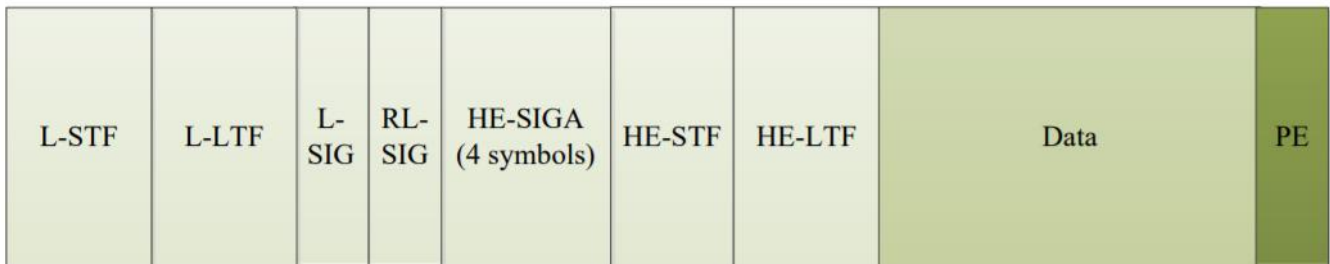

FIGURE 29: HE ER SU PDU FORMAT

- HE TB PDU Format:

After receiving the trigger frame, many STAs simultaneously transmit UL frames according to the resource allocation information in the trigger frame. Therefore, the UL MU transmission format is called a trigger-based format, as shown in Figure 30. Compared to HE MU PDU, this format does not have HE-SIG-B because AP indicates the resource allocation information in the trigger frame.

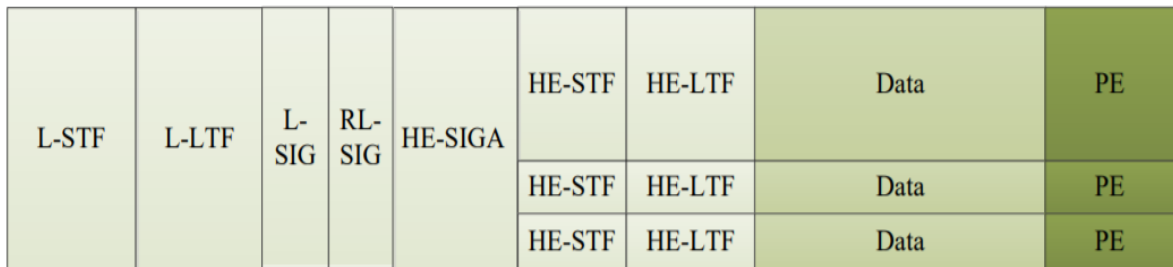

FIGURE 30 : HE TB PDU FORMAT

There are two preamble parts where the synchronization between transmitting and receiving radio signals are legacy and high efficiency. Legacy stations can easily decode legacy preambles which are used for backward compatibility. HE preambles are used for communication between 802.11ax radios, for example, regarding OFDMA, MU-MIMO and BSS coloring.



## 2.6 BSS COLORING

To maximize Quality of Experience (QoE) and to address issues such as CCI and OBSS (Overlapping Basic Service Set) interferences seen in older 802.11 networks, IEEE 802.11ax introduced following concepts.

- The OBSS is the overlap or interference between a BSS with which the STA is associated with and neighboring BSS with which STA is not associated with. Here STA refers to STATION or client Wi-Fi devices.
- BSS color method as described below for distinguishing between BSSs on the same RF channel.
- OBSS Packet Detection (PD) is the signal detection ability of other BSSs.
- Clear Channel Assessment threshold control (CCA) is the ability of Wi-Fi device to change the CCA sensitivity according to the relevant access point (AP) and current transmission.

AP (Access Point) and its connected clients are called as BSS (Basic Service Set). [17]

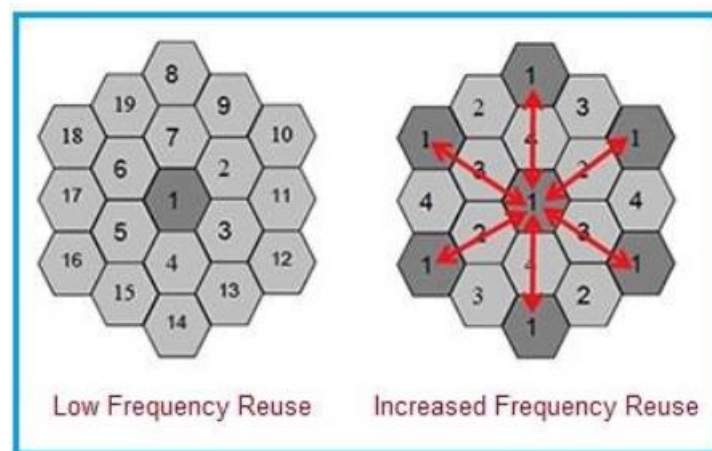

FIGURE 31 : FREQUENCY REUSE CASE FOR 20 & 80 MHZ CHANNELS

The Figure 31 shows a case of low frequency reuse for 20 MHz channels. No interfering co-channel in this case. The Figure 31 also shows high frequency reuse case for 80 MHz channels. All the same frequency channels used by BSSs in the Wi-Fi network are blocked.

In such a dense Wi-Fi network, the neighbor AP may interfere with co-channel. Stations on overlapping areas will backoff excessively. This situation is called OBSS interference (Overlapping Basic Service Set) or CCI (Co-Channel interference) [21].

### 2.6.1 WHAT IS BSS COLORING?

Above problem of legacy 802.11 networks has been alleviated by the introduced concept BSS coloring in IEEE 802.11ax version. Using this feature, the stations detect transmissions from another network and take right action accordingly.

The Figure 32 illustrates BSS coloring concept. Here same channel BSSs are only excluded only in color matching.



FIGURE 32 : BSS COLORING CONCEPT

In BSS coloring concept, each BSS (AP) uses a different unique color that is 6 bits in size and carried by signal preamble or SIG field. Each STA (client) learns its own BSS when connecting and other BSSs or OBSSs.

### 2.6.2 BSS COLORING (BENEFITS AND ADVANTAGES)

- It is a technique used to improve co-existence of overlapping BSSs (OBSS) and to allow spatial reuse in a channel.
- Signals with same BSS color use low RSSI (received signal strength indication) threshold for postponement. This reduces collisions on the same BSS. This means BSS coloring helps in mitigating problem of CCI (co-channel interference) found in legacy WIFI networks.
- Different BSS color signals use a higher RSSI threshold for deferral. This allows use of more simultaneous transmissions.

## 2.7 TARGET WAKE TIME

Target Wake Time (TWT), one of WiFi 6's most clever features, helps devices conserve power, and prevents channel contention.

At a high level, Target Wake Time is the function that allows an access point to define a specific time or set of times for individual devices to access the wireless network.

In other words, it's the mechanism that allows devices to negotiate when and how often they turn on and off, based on when they need to send and receive data. This new functionality has a significant impact on device battery life since not all devices need to be switched on during all hours of the day — they only turn on when they need to perform a task.

Since TWT enables device wake time to be scheduled rather than being determined by connection, a WiFi 6 access point can determine when a device should sleep and when to wake. In theory, this means IoT and mobile devices could remain off for long periods of time — even days or weeks — to conserve battery. This also helps optimize spectral efficiency by reducing contention and overlap between devices.

An 802.11ax AP can negotiate with the STA participants using the Target Wake Time (TWT) function to specify a specific time or set of times for individual stations to access the medium. The STAs and the AP exchange information that includes an expected duration of activity. In this way the AP controls the level of contention and overlap among STAs needing access to the medium. 802.11ax STAs may use TWT to reduce energy consumption, enter a sleep mode until they reach TWT. In addition, an AP may also devise schedules and deliver TWT values to STAs without individual TWT agreements between them. The standard calls this process Broadcast TWT operation (Figure 33) [17].

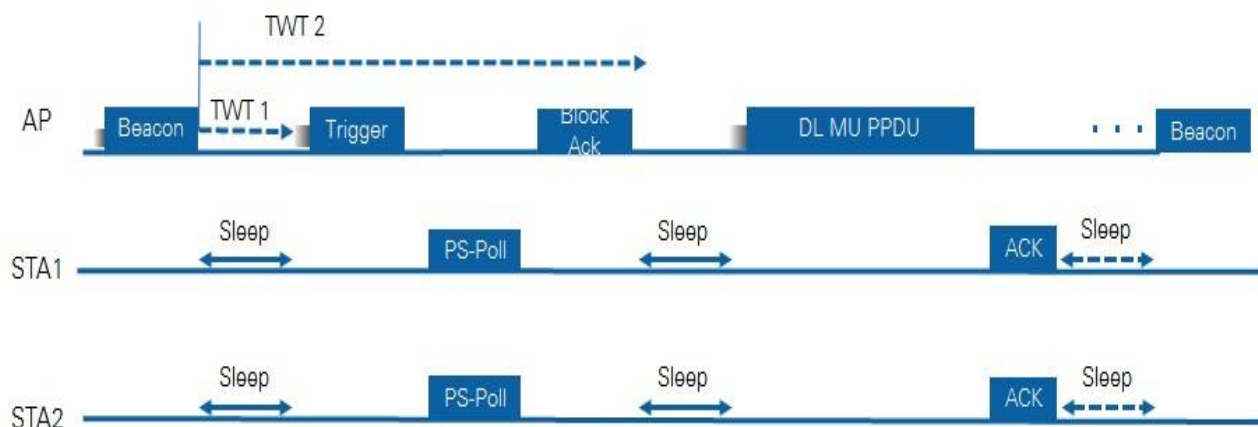

FIGURE 33 : EXAMPLE OF TARGET WAKE TIME BROADCAST OPERATION

## 2.8 USE CASES FOR WI-FI 6 TECHNOLOGY

Developments in 802.11ax will benefit a wide range of use cases but are particularly important for dense environments where large numbers of connected users and devices on the network [22]. Some scenarios to benefit from advancements in the 802.11ax standard are:

### a) Large public venues (LPVs):

Stadiums and conference centers are common Large Public Venues that offer more and more Wi-Fi to enhance the experiences of fans or participants, increase customer interactions, and create value-added services such as showing instant replays on fan devices or the ability for participants to order food from their seats. Stadiums and conference centers with tens of thousands of users all connected to the Wi-Fi at the same time pose unique challenges of scale and density. The 802.11ax advancements around OFDMA, 1024 QAM, OBSS coloring, and the faster PHY rates will make it easier for LPV owners to create new business opportunities by offering improved customer service.

### b) Transportation hubs:

The public transport stations are also offer public WIFI. Like stadiums, transport hubs have high densities of people trying to connect to the networks at the same time. However, these hubs face the unique challenge posed by transient devices that are not connected to the Wi-Fi network but are still send traffic management that congests it. The 802.11ax advancements with OFDMA and BSS coloring provide the tools to manage the challenge with these dense environments.

### c) IoT and Smart City deployments:

These deployments are facing a variety of challenges. In some cases, there may be a high volume of devices all attempting to communicate all at once, such as at a manufacturing site. In others, a small number of devices could be idle and need to "phone home" once a day. Power efficiencies in 802.11ax can enable devices to go into deep sleep mode and turn on their transmitters at predefined intervals to extend field time without maintenance.

#### d) Education:

College and university campuses have high densities of Wi-Fi users in areas such as libraries, conference rooms, lecture halls, and student unions as well as at graduation and other campus events. Primary/K–12 education trends as learning video-based, 1:1 computing, connected classrooms, and IoT are creating an airtime capacity crisis, which stresses network reliability.

## 2.9 USER EXPERIENCE OF WI-FI 6

802.11ax, a next generation wireless standard by the Wi-Fi alliance, is still ambiguous to implement. However, one of the practical components of the final year project was about the end-user experience. 802.11ax is the most advanced 802.11 network. This network is the future of the wireless network. Since it is quite new technology, there are some disadvantages about it. In section 2.10 – 2.11, a few advantages and the disadvantages of the 802.11ax network.[23]

### 2.10 ADVANTAGES IN WI-FI 6

Previous chapters of this thesis have discussed the technical advantages of 802. 11ax.As described in the technical part, there are many advantages of the network. Some of the advantages of this network are listed below:

- Significant increase of data rates. The previous networks had a standard of 3.5 Gbps however, 802.11ax will have 9.6 Gbps in theory.
- The Wi-Fi router will be able to connect more devices than the previous network's routers. Because to the latest of OFDMA technology, the bandwidth division for the devices connected will be separate. This means that all the devices will always get the bandwidth, even when one of the devices connected in the router may need more bandwidth. This means that no device connected in the router will experience bandwidth traffic problem unlike the problem that had occurred in the previous networks.
- With the help of TWT (Target Wake Time) the battery life of the smartphones or laptops is saved. **The TWT is only introduced in the 802.11ax network.** Previous technology did not have this property resulting in drainage of battery life
- The network will be backward compatible. Since 802.11ax supports both 2.4 and 5 GHz devices, users can connect their existing devices on the Wi-Fi 6 router. However, they cannot enjoy the full benefits and services of the Wi-Fi 6 network.

- The security of WIFI will be better. With the introduction of WPA3 security in 2018, this network will have WPA3 (Wi-Fi protected access 3) security which will be able to combat the modern threat that the previous security such as WEP, WPA2 could not face. WPA3 also provides 192-bit encryption.
- The network can be deployed in both outdoor and indoor environments. For indoor environment, a shorter CP (cyclic prefix) is used whereas for outdoor environments it uses longer symbol durations and a cyclic prefix.

### **2.11 DISADVANTAGES IN WI-FI 6**

As 802.11ax is still in developmental and starting phase, the network is not yet perfect. Although networks are new and modern, there are still few limitations of the network. Some of the disadvantages of 802.11ax listed below:

- Since 802.11ax is still in developmental phase, there might be many obstacles for developers. Additionally, the devices currently under construction may not be compatible with the network in the future.
- The total cost is very high. Devices such as smartphones, laptops and routers were expensive. The wired broadband of gigabit band connection is also required for full use of the WIFI 6 itself is expensive.
- Wi-Fi 6 range is small, compared to 5G networks. There will be a network outage if there is blockage between router and client devices.

### 3. THE FUTURE OF WI-FI

#### 3.1 WI-FI 6E: “THE NEW LANE”

In April 2020, the FCC unanimously cleared the way for a third band: 5.925-7.125 GHz [24]. Such an additional spectrum, referred to as the 6 GHz band, almost four times the amount of available bandwidth. The new 6 GHz band will be accessed by unlicensed devices based on rules designed to protect existing services. Wi-Fi 6 is ready to use the 6 GHz spectrum as it is available worldwide, and devices equipped with the chips and radios needed to operate in the new band will be marked ‘6E’, the E meaning extension. The Wi-Fi Alliance plans to launch its Wi-Fi 6E certification in early 2021-2022, with over 300 million compatible devices are expected to hit the market the same year.

#### 3.2 THE IMPORTANCE OF 6GHZ

Over the next decade, Wi-Fi faces many difficult challenges. Key among them are the growing demands placed on Wi-Fi networks, leading to increased congestion, performance limitations, and reduced Quality of Service (QoS). Most Wi-Fi devices use increasing amounts of data per device, including high-resolution music and video streaming, online gaming, video calling, application and firmware updates, social networking, digital downloads and web data content. The huge increase in active Wi-Fi devices at home in recent months and resulting increase in traffic because of COVID-19 confirmed Wi-Fi as a vital utility, strongly proving both its importance and limitations.

The requirements will grow over time as the resolutions increase to 4K & 8K in the future and require greater performance. The development of cloud services and uploading of content to social media and the sharing of websites also results in more uplink traffic. A recent report commissioned by the Wi-Fi Alliance said that, by 2021, Wi-Fi networks will need significantly more spectrum to meet increased traffic requirements. The report also said that by 2025, it would need at least between 500 MHz and 1 GHz of additional spectrum to satisfy maximum usage, with higher estimates placing this between 1.3 GHz and 1.8 GHz.

As a result of this traffic explosion, mobile phone companies are increasingly looking to unload traffic into Wi-Fi. Likewise, consumers with limited data plans decide to connect to Wi-Fi when they are at home or in public places to circumvent these restrictions. To do this, however, the user experience should be comparable to the existing mobile network, and the Wi-Fi network must be able to handle that additional traffic [25].

### 3.3 IEEE 802.11AX/BE FREQUENCY BANDS

- 2.4GHz: 11 channels of 20MHz, only 3 non-overlapping channels
- 5 GHz: 25 channels of 20MHz over 555 (semi-contiguous) MHz
- 6 GHz: up to 60 channels of 20MHz over 1200MHz

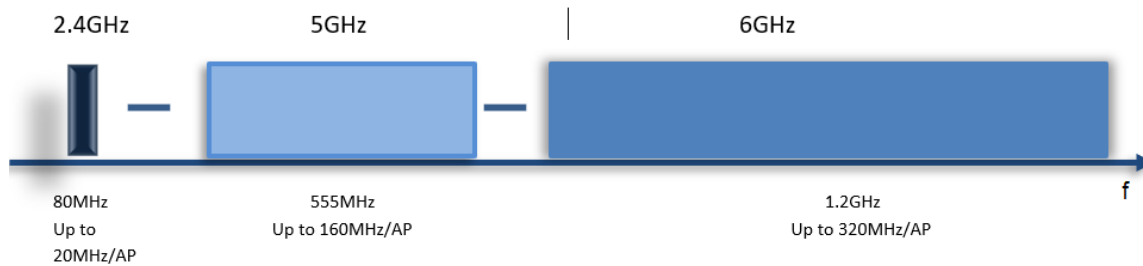

FIGURE 34 : FREQUENCY BANDS

### 3.4 BENEFITS OF 6 GHz

- More than Double the Existing Available Spectrum:** Up to 1.2 GHz of additional spectrum will be allocated for Wi-Fi, essentially doubling the existing spectrum available to Wi-Fi today. High-density deployments, such as airports, stadiums, conference halls, and other venues suffering from congestion, will benefit greatly from this additional capacity, while the greater availability of 160 MHz channels in the 6 GHz band will enable low-latency Multigigabit connectivity to better support a number of advanced use cases.
- A Clean Band:** 6 GHz Wi-Fi will only support Wi-Fi 6 and beyond devices. Essentially, an access point 6 GHz (AP) will only be able to talk with Wi-Fi 6 and beyond customers and will not be share the airtime and bandwidth with earlier generations of Wi-Fi, such as Wi-Fi 5. This keeps the band clean and ensures that slower devices do not prevent the network.
- Improved Legacy Networks:** Without the availability of the 6 GHz band, 5 GHz could become extremely congested over time. 6 GHz availability could, therefore, bring concrete benefits for Wi-Fi 6 clients and legacy clients operating in that spectrum, freeing up part of the 5 GHz spectrum to help boost performance, especially as Wi-Fi 6E will absorb much of the high-performance usage currently on 5 GHz.
- Improved Backhaul and Multi-AP Systems:** 6 GHz could enable the guaranteed multigigabit throughput throughout the entire home by utilizing the band as the backhaul technology for multi-AP mesh deployments. Although it may take some time for 6 GHz clients to become mainstream, existing Wi-Fi devices could potentially benefit from 6 GHz backhaul throughout the home once 6 GHz networking equipment arrives. This could lead to multi-gigabit throughput coverage throughout the house, leading to better user



experiences across a wide range of high-performance applications, from video streaming to gaming and Augmented Reality (AR).

- e) **Reliability:** Wi-Fi 6E, unpolluted with older Wi-Fi devices, could provide much more reliable and consistent performance than Wi-Fi 5 could be achieved. Some corporate deployments have held back on transitioning to wireless technology due to latency and bandwidth requirements. Now, companies can move to Internet Protocol (IP) phones and support collaborative low-latency applications or other basic services by Wi-Fi, instead than costlier and less flexible wired Ethernet solutions.
- f) **Application-Specific Deployments:** The clean 6 GHz band could allow specific applications to be leveraged on the 6 GHz band. Augmented reality (AR) and Virtual Reality (VR) applications could be transferred to 6 GHz Wi-Fi 6E to ensure reliability and performance. Similarly, the backhaul could shifted to 6 GHz for higher throughput. For critical industrial applications, mission-critical machinery and equipment could leverage this band for guaranteed performance and low-latency services. Chipset vendors like Broadcom have already introduced client Wi-Fi 6E chipsets capable of supporting more than 2 Gbps utilizing the 6 GHz band.
- g) **High-Throughput ,Low-Latency Non-Line-of-Sight Performance:** Applications such as VR/AR headsets require increasing amounts of throughput, while maintaining extremely low latency.6 GHz could potentially enable non-line- of-sight AR/VR applications. It could also offer better casting performance than 5 GHz Wi-Fi, possible allowing low-latency screen mirroring or screen sharing from mobile devices or game consoles with more flexibility than 60 GHz [25].

### 3.5 6 GHz Wi-Fi CHALLENGES AND STRATEGICS

- a) **Lack of Awareness and Education:** Some chipset vendors have expressed that the wider industry is still larger in the 6 GHz learning cycle and most requests do not include a 6 GHz requirement. It may, therefore, take longer to raise awareness and devices to enter the market. However, FCC approval, and announcement 6E, ABI Research expects that service providers, Original Equipment Manufacturers (OEMs), and industrial wireless networks more widely will absorb the benefits of Wi-Fi 6E.
- b) **Cost:** There will be increased cost to support Wi-Fi 6E, and the 6 GHz band. Vendors need to think carefully about how soon they will support the technology and it may not always be a simple upgrade. While 6 GHz may gain some initial support at the extremely high end, it will probably take some time to switch as other components become more widely available on both the infrastructure and customer. However, this is expected to decrease over time.
- c) **Transition to New Band:** Historically, switching to a new band took time, 5 GHz Wi-Fi took time to go mainstream, and 60 GHz WiGig and sub-1 GHz Wi-Fi HaLow are still trying to

achieve. On a more positive note, some in the industry believe it could take a similar time frame to 802.11ac, which was validated in late 2013, and by 2016, the technology had already reached 1 billion chipset shipments. The 6 GHz validated by the end of 2020 and some expect similar volumes during the 2023 to 2024 time frame because of the enormous benefits it can offer. However, much will depend on regional availability of spectrum, the development of infrastructure and the support of mainstream device to create a complete ecosystem 6 GHz. [25]

#### 4. 802.11BE WI-FI 7: EXTREMELY HIGH THROUGHPUT

Real-time application has appeared in recent years and is attracting increasing attention. For example, AR and VR, wireless video conferencing, online gaming and the cloud mobile computing are typical cases of real-time applications. Some applications such VR and AR require both high speed and low latency. These types of services require the network not only to provide extremely high throughput, but also ensures low latency (especially worst-case latency and deterministic latency) and jitter. This puts very strict requirements and challenges for wireless networks. [26]

*Ultra-high definition video traffic and real-time traffic is the target scenarios of IEEE 802.11be. To efficiently support the target scenarios, the main technical objective of IEEE 802.11be is to achieve extremely high throughput (at least 30Gbps) and improving the worst latency and jitter.*

##### 4.1 EVOLUTION TO WI-FI 7

	xBC	Speed	Main Features	Comment
Mature Wi-Fi 5	Dual	1Gbps		160MHz channels were supported – but clients did not typically support
Current Wi-Fi 6	Dual and Triband	4x4 2.5Gbps	4x speed Lower latency OFDMA Better Battery Life	Wi-Fi 6 AP performs better for mixed Wi-Fi 4,5,6 clients than a Wi-Fi 5 AP Typically 25% improvement in mixed Wi-Fi client environment 160MHz channels supported Matched with 2.5Gbe Ethernet support
2022 Wi-Fi 6E	Triband	4x4 4Gbps	Immediate use of Wi-Fi 6 features for the client	Wi-Fi 6E allows ONLY Wi-Fi 6 devices with 6GHz support to operate in the U-NII5 6GHz band. Immediate full use of the performance of Wi-Fi 6 with 160MHz channels and QAM 1024 modulation Perfect Solution for congestion (MDU) and low latency Wi-Fi services.
2024 Wi-Fi 7	Triband	4x4 8 Gbps	320MHz channels	Wi-Fi 7 (currently IEEE802.11be specification) is extending the channel width to 320MHz. Potential for 10Gbps like wireless backbone across the home

FIGURE 35 : THE EVOLUTION OF WIFI FROM 5-7

## 4.2 HOW EXTREME HIGH THROUGHPUT CAN BE ACHIEVED ?

Data Rate = # data subcarrier x databits per symbol x # SS / symbol – time  
 ↻ bandwidth ↻ modulation & coding ↻ spatial streams

- **320 MHz Bandwidth (ax: 160 MHz):**  
802.11be will add support for: 320Mhz, 160+160MHz, 240/160+80Mhz transmission by reuse of 802.11ax tone plans.
- **16 Spatial streams (ax: 8 streams)**  
up to 16 spatial streams with some MIMO protocol enhancements
- **Higher order modulation 4096 QAM (ax: 1024 QAM):**  
Requires “quite clean air” to use

*1192 subcarrier x 10 bits/symbol x 16 streams / 13.6μs < 23 Gbps*

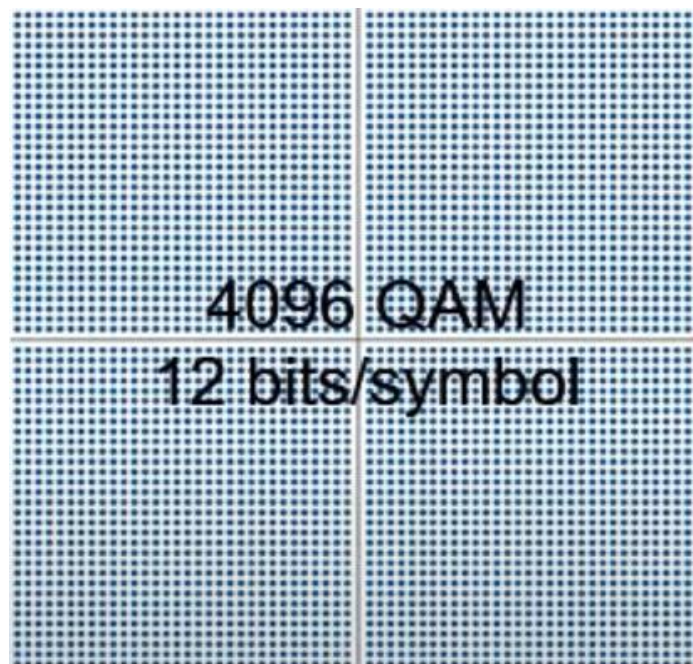

FIGURE 36 : HIGHER ORDER MODULATION

### 4.3 THE DEVELOPMENT TIMELINE OF IEEE 802.11BE

Despite its name, the Extremely High Throughput of 802.11be will be much higher than high peak data rates. Sure enough, Wi-Fi 7 is projected to support at least 30 Gbps / AP, about four times faster than Wi-Fi 6, while ensuring backward compatibility and coexistence with legacy devices in the 2.4 GHz, 5 GHz & 6 GHz unlicensed bands.

At the same time, 802.11 talk about how to support the RTA in Wi-Fi networks. The work in this direction started in November 2017 with a presenting the WIFI Time-Sensitive Networking (TSN) as a part of the 802.11 Wireless Next Generation Standing Committee.

The 802.11be Task Group (TG) is recognized the need for and aims for lower latency and higher reliability to enable Time-Sensitive-Networking (TSN) use cases. The first is considered as a tool for real time applications such as AR and VR, gaming, and cloud computing, required reduced delay times less than 5 ms.

To accelerate the development and commercialization of WIFI 7, the timeline is shown in Figure 37, the 802.11be TG turn away from the typical single-phase development cycle, and agreed on two phases. The first will focus on a number of features that are considered high-priority in terms of their gain and complexity ratio, time for standardization and implementation, and the related interests and market needs. [27]

Table 6 shows the basic technologies and their phases.

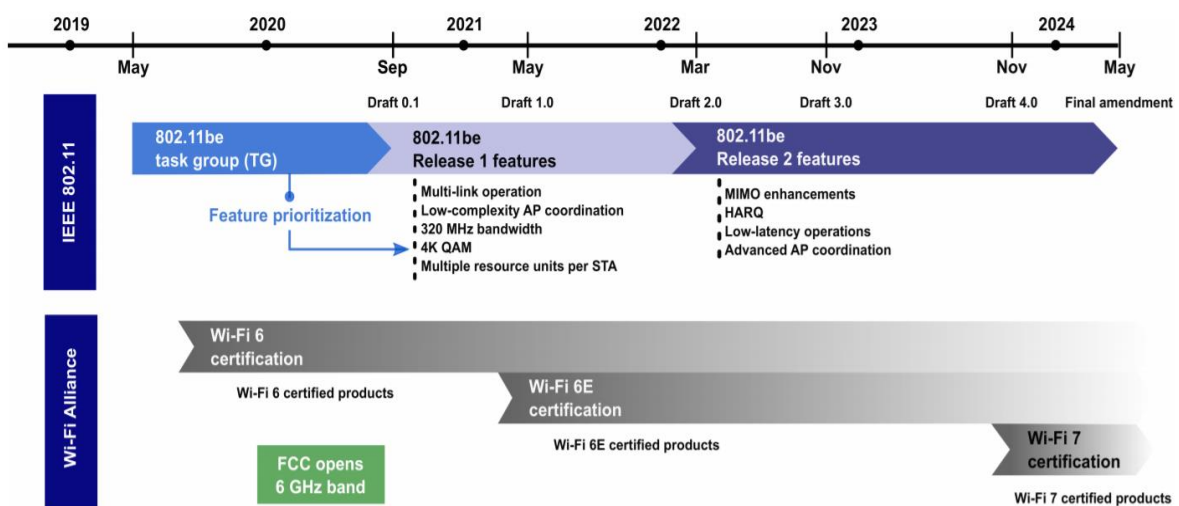

FIGURE 37 : TIMELINE OF THE 11BE STANDARDIZATION PROCESS

Features	Detailed technologies	Phase
PHY Enhancements	<ul style="list-style-type: none"> <li>• Wider bandwidth such as 320MHz &amp; 240MHz</li> <li>• Tone plan, preamble, and PPDU format</li> <li>• Multiple RUs per STA</li> <li>• 4096-QAM</li> <li>• 16 spatial streams</li> </ul>	Phase 1 Phase 1 & maybe Phase 2 Phase 1 Phase 1 Phase 2
Multi-band operation	<ul style="list-style-type: none"> <li>• A series of schemes for multi-link operation</li> <li>• Other technologies such as multi-band discovery</li> </ul>	Phase 1 Phase 1 & maybe Phase 2
AP coordination	co-BF, co-JT, co-SR, co-TDMA, and etc	Phase 2 & maybe Phase 1
Enhanced Link Reliability	HARQ and other potential technologies	Phase 2
Latency & Jitter Guarantee	Time-sensitive network (TSN) and other potential technologies	Phase 2
Others	Other potential technologies	Phase 2

TABLE 6 : KEY TECHNOLOGIES OF IEEE 802.11BE

Another critical issue affiliated to WIFI 7 is its coexistence with 3GPP cellular network technologies operating in the same unlicensed frequency bands. To learn the coexistence issues related to WIFI and mobile networks, IEEE 802.11 started a Coexistence Standing Committee (Coex SC). The task of Coex SC is to create contact with 3GPP. Despite many activities and even a joint workshop with participants 3GPP and IEEE 802.11 in Vienna, in July 2019 technical solutions have not yet been approved. Maybe the reason is that both IEEE 802 and 3GPP do not will change their own technologies to be alignment them at the same time. Therefore, there is no clear picture which of the solutions that have been discussed in Coex SC will be a part of WIFI 7. [27]

#### 4.3.1 RELEASE 1 FEATURES

As shown in Figure 37 Release 1 (R1) features are expected to reach a mature specification in Draft 1, due in May 2021, with the possibility of further extending and improving them until the release of Draft 2 in March 2022.

The (Release 1) includes:

1. **Multi-Link Operation:** The 802.11be target for efficient operations in all available bands, 2.4, 5 & 6 GHz, for load balancing, aggregation of multi-band, and simultaneous downlink/uplink transmission. In 802.11be, a multi-link device (MLD) is defined as one with multiple connected APs or STAs, and a single MAC Service Access Point (SAP) to the above logical link control (LLC) layer. Also was introduced a MAC address which in a unique way identifies the MLD management entity. The most important features of multi-link control can be summarized as follows:

- *Multi-link discovery and setup*: MLDs will be able in a dynamic way to tell their ability to exchange frames for each link pair at the same time. Each individual AP/STA can also supply information on the operating parameters of the other connected APs/STAs with the same MLD.
  - *Traffic-link mapping*: When creating multi-link, all Traffic Identifiers (TIDs) used to classify the frames based on their quality of service (QoS) assigned to all installation links. An update of this mapping can then be traded by any MLD involved. In addition, the MLD will use a single rearrangement buffer for QoS data frames of the same TID transmitted over multiple links.
  - *Channel access and power saving*: Each AP/STA of a MLD is performing independent channel access through its links and maintains its own power state. To ease an efficient STA power management, Aps can use an activated link to transfer indications of stored data for transmission to other links.
2. **Low-Complexity AP Coordination**: 802.11be will be able to support multi-AP coordination, with Aps advertising their capabilities in beacons / management frames. Coordinated spatial reuse (CSR) is one low-complexity implementation that can be included in R1. In CSR, a sharing AP that has acquired a transmission opportunity (TXOP) can trigger one or more other shared Aps to implement at the same time transmission with suitable power control and link customization. This coordination will make more changes for spatial reuse and restrict the number of collisions when the comparison with the spatial reuse schemes is available in 802.11ax.
3. **Direct Enhancements of 802.11ax**: The 802.11be TG will also determine a number of direct upgrades to the now 802.11ax standard. These include:
- Support of 320 MHz transmissions – 160 MHz x 2 of 802.11ax.
  - Use of higher modulation orders, optionally supporting 4096-QAM – up from 1024-QAM in 802.11ax – with a strict -38 dB requirement on the error vector magnitude (EVM) at the transmitter.
  - Using higher modulation orders of multiple resource units, groups of OFMDA tones, per STA. This extra degree of flexibility leads to more efficient spectrum utilization. [27]

### 4.3.2 RELEASE 2 FEATURES

Although (Release 2) features will be standardized probably in November 2022 and November 2023, 802.11be TG has already started work on this and has made a important progress in Spec Framework Document (SFD).

*The main features are described below:*

1. **MIMO Enhancements:** 802.11be will double the maximum number of supported single-user MIMO (SU-MIMO) and multi-user MIMO (MU-MIMO) spatial streams up to 16, with the increase of capacity. In the condition of MU-MIMO, the 802.11be TG has agreed to cut down the maximum number of spatially multiplexed STAs and spatial streams per STA to 8 and 4.

- Vendors slowly add antennas to APs gradually.
- A range of products remains, and the highest number of antennas is found only in high quality products.
- Historical, 16SS will maybe it will appear in technology about 2024.
- Since there cannot be possible to have 4+SS clients, to support UL/DL MU-MIMO on AP would be logical.
- 16SS maybe can be optional in a EHT AP

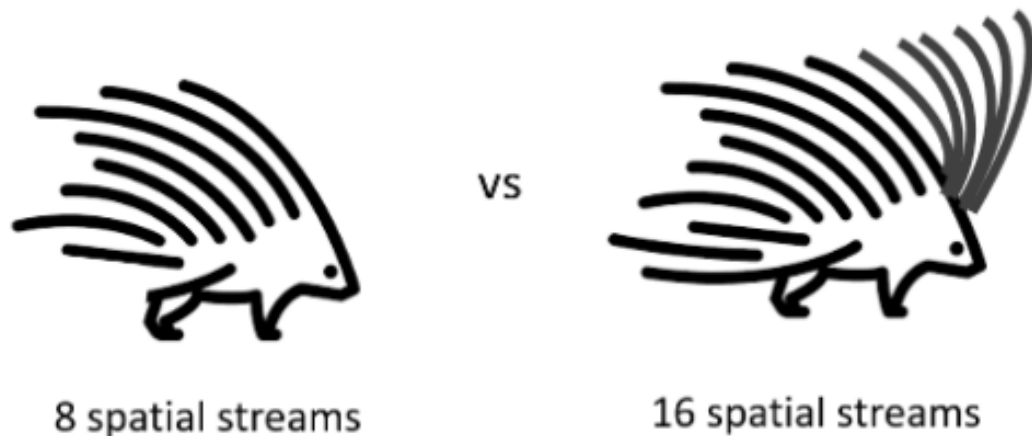

FIGURE 38 : 8SS VS 16SS

2. **Hybrid Automatic Repeat Request (HARQ):** In Release 2 we will see the entry of HARQ, where devices do not reject bad information but try to slowly to combine it with re-accepted units to increase the probability of correct decoding.
3. **Low-Latency Operations:** Given the TSNs business appeal, the SFD will also get the protocol enhancements dedicated to reducing worst-case latency and make a jump in reliability. These solutions can be based on multi-link operations-providing a different QoS per link or on AP coordination, for more aggressive spectrum reuse and less harmful collisions.
4. **Advanced AP Coordination:** To take an advantage of Multi-AP coordination, the 802.11be TG has agreed to support the following three projects:
  - **Coordinated OFDMA:** At 802.11be, an AP that acquires a TXOP will be able to share frequency resources in multiples of 20 MHz channels with a set of neighboring Aps. For efficiency reasons, the shared AP can request neighboring Aps to mention their resource requirements.
  - **Joint single-and multi-user transmissions:** Sending data collectively to their associated STAs requires Aps to block phase synchronization errors and offsets timing. It found that joint transmissions provide gains when reasonable values for these damages, provided that there is available backhauling. Since cooperative APs require CSI from both connected and non-connected STAs, 802.11be will set a common multi-AP sounding scheme. This way, APs at the same time will transmit their sounding frames and the STAs addressed will transmit CSI feedback at all Aps.
  - **Coordinated beamforming:** This technique holdings the capability of modern multi-antenna APs to spatially multiplex their STAs, while co-placement radiation nulls to/from neighboring non-associated STAs. While the CSI have to direct radiation nulls can be taken through the mentioned above joint multi-AP sounding scheme, CBF may also benefit from simple sequential sounding procedure that will be part of 802.11be. In addition, CBF does not require shared data processing as each STA transmits-receives data to-from a single AP, from this reducing the backhaul requires joint transmissions. Since CBF can offer improvement in throughput and latency enhancements while keeping the complexity.[28]



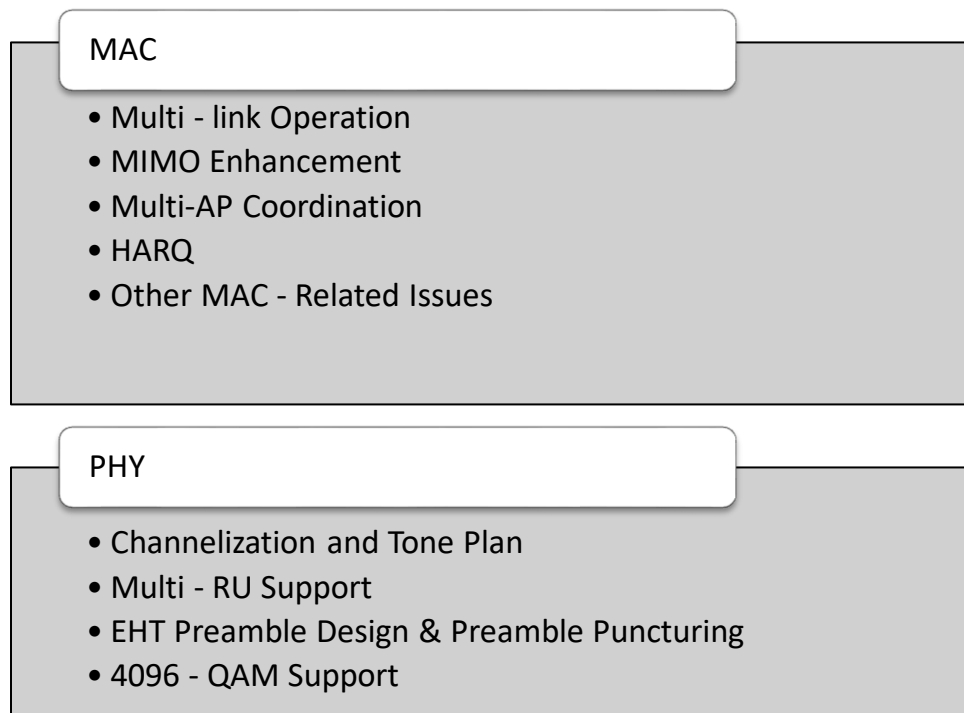

FIGURE 39 : 802.11BE PHYSICAL LAYER (PHY) & MEDIUM ACCESS CONTROL LAYER (MAC)

#### 4.4 PHYSICAL FRAME

To support all the new physical features, 802.11be needs to reform the frame formats. Many changes are related to the PHY preamble of the frames (Figure 40). For backward compatibility, in the 5 GHz and 6 GHz bands, all Wi-Fi frames start with the legacy preamble of 11a. The legacy preamble includes a short training field and a long training field used for frame detection and receiver synchronization. The next OFDM symbol carries the legacy signal field (L-SIG) that says which MCS is used for the next signal and what is the frame length is. Wi-Fi does not have a clear way to show the physical protocol version.

In all WIFI versions beyond 11n, the MCS and frame lengths is indicated on the L-SIG are fake, but legacy devices use calculation the duration of framework. To diversify of the frame formats, 11n, 11ac, and 11ax handles the OFDM symbol modulation following L-SIG and the content of L-SIG (Figure 41). Specifically, in 11n, L-SIG is followed by an HT-SIG field, which consists of two OFDM symbols that are BPSK with 90 degrees (QBPSK). Since QBPSK it's not being used in previous WIFI modifications, after receiving such symbols, a device realizes that the format of this frame is described in 11n modification. In the 11ac we have two VHT-SIG-A symbols after L-SIG :

The first one is modulated by BPSK and the second uses QBPSK. The length indicated on the L-SIG is a multiple of three. As for 11ax, first, it repeats L-SIG and shows the length equal to one or two modulo three. Secondly, the High Efficiency signal field (HE) contains two OFDM symbols. The first is modulated with the QBPSK, while the second one is modulated by BPSK or QBPSK. The result of this modulation is the combination with BPSK/QBPSK selection identifies one of the four 11ax frameworks.

The frame formats of 802.11be and beyond will be able to use the length L-SIG divided by three. In addition, there was a decision from 802.11be developers to stop the bad practice of indication of the frameworks formats and introduced a two OFDM-symbol long universal SIG (U-SIG), which is able to look ahead of forward compatibility.

The U-SIG contains version-independent updates, followed by version dependent information. Version independent information includes a three-bit PHYSICAL ID, one-bit UL/DL flag, (BSS) color, transmission (TX) opportunity (TXOP) duration and bandwidth.

The information it also depends on which version will probably include such of this information as the HE signal field (the number of EHT long training fields symbols, periodicity of medium length, and space-time block coding flag) and some of 802.11be feature updates.

The next EHT-SIG field stores information are not included in U-SIG but is necessary for the new capabilities of 802.11be. To include all the information, EHT-SIG its able to use its own MCS (its different from data MCS) and can understand a many number of symbols indicated in U-SIG. The EHT-SIG field consists of the ordinary field and a user-specific field.

The common field have information about MCS, how many space-time streams, , the duration of the guard interval, the RU allocation and the coding.

There are specific user fields for MU frames and carry specific information for individual STAs. The EHT short training field (STF) and the EHT long training field (LTF) follow EHT-SIG and, similar to HE analogues, give for good time and frequency coordination when using MIMO or OFDMA. The 802.11be come into longer difference of STF & LTF from 802.11ax, which are kind for expanded range and better channel assessment.

If a framework is going to transmit in a wide bandwidth, EHT-STF and EHT-LTF are going to repeat every 20 MHz. The period of every 20 MHz copy is rotated to reduce the peak-to-average power ratio and enhance correlation performance. New 320 MHz channels need a new phase rotation design that considers the 320 MHz tone plan and possible puncturing. [29]

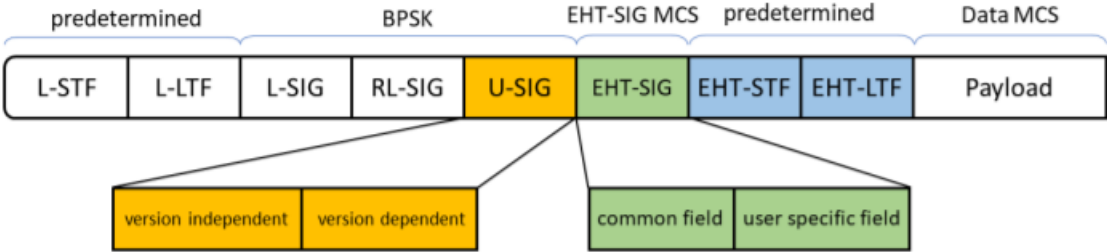

FIGURE 40 : THE EHT FRAME FORMAT

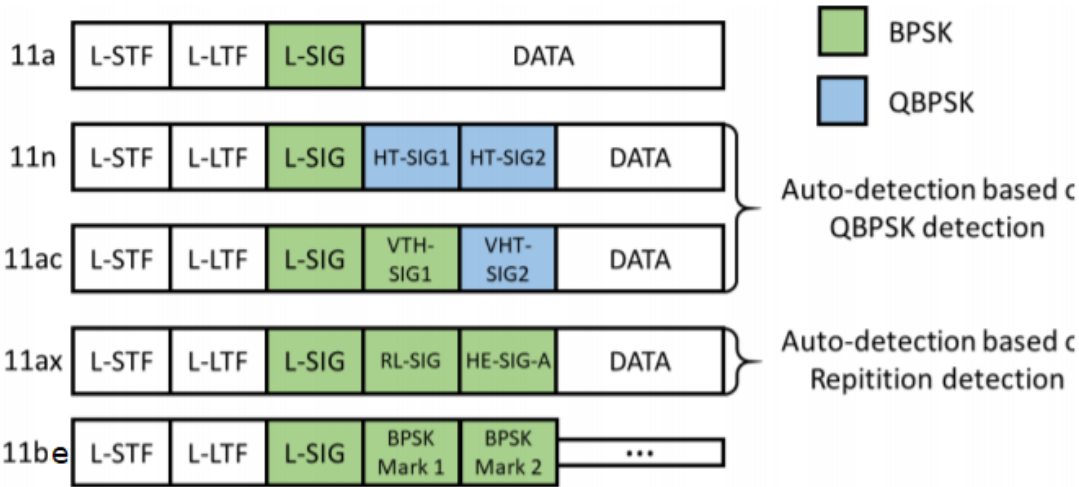

FIGURE 41 : PREAMBLE AUTO-DETECTION FOR LEGACY FRAMES

## 4.5 THE MAC LAYER

### 4.5.1 MULTI-LINK OPERATION

Due to the limited and busy unlicensed spectrum in 2.4 GHz & 5 GHz, the existing IEEE 802.11 WLANs (IEEE 802.11ax) have low QoS to handle the new use cases, VR/AR. To distribute the max throughput of at least 30 Gbps, EHT extend its bandwidth by aggregating multi-band into 2.4 GHz, 5 GHz & 6 GHz bands, and gain a bandwidth up to 320 MHz. Challenges like which channel frequency can be selected over a wider and non-continuous bandwidth, the backward compatibility, the different types of multi-band operations, and coexistence with existing legacy STAs in zones 2.4 GHz, 5 GHz and 6 GHz bands would happen when multi-band aggregation are performed. In the legacy multi-band operations, Fast Session Transfer (FST), there is a limitation that MAC service data units (MSDUs) belong in a single traffic identification (TID) that can only use single band, as a result in significant MAC overheads for session transfer. Thus, to improve transmission flexibility and minimize the MAC load, the existing MAC models are need a important upgrades in EHT, an STA can transmit frames of the same TID or different TIDs over multiple bands at the same time or not simultaneously.

The name multi-link that used in EHT is a multi-band for the MAC enhancements. The multi-link is a little bit broader sense than multi-band.

IEEE 802.11be allows a logical multi-link (ML) device (MLD) to consist of a series of physical entities. As shown in the Figure 42, a logical AP MLD is multiple APs and the logical non-AP MLD consists of multiple non-AP STAs. In different from legacy IEEE 802.11, the ML function of IEEE 802.11be suggests only one entity connect to the upper layer (like the network layer), while the ML function of legacy IEEE 802.11 has many independent entities connected to the upper layer. That is, legacy IEEE 802.11ML function is equal to quite relevant independent APs or STAs in one device.

In Figure 42, the flow-level of multi-link operation means that an AP or STA can allocate its multiple traffic streams to different links, but flow-level multi-link operation does not allow data frames from one traffic stream to be immigrated to another links expect approves a complex processes called fast session transfer (FST). Packet-level multi-link operation is the fact that an AP or STA can in dynamic transfer any of frames to different links. That means the data frames belong to the same traffic stream can be flexibly hosted on different links. As shown in the Figure 42 if the transmission of the one frame (frame 4) fails on one link, the retransmission process can be arranged on another link. The block acknowledgement (BA) corresponding to the transmission of a link can be sent to another links. Obviously, the activity of multi-link operation at the packet level is to more flexible that can improve the performance of system, but the MAC control is more complicated. [29]

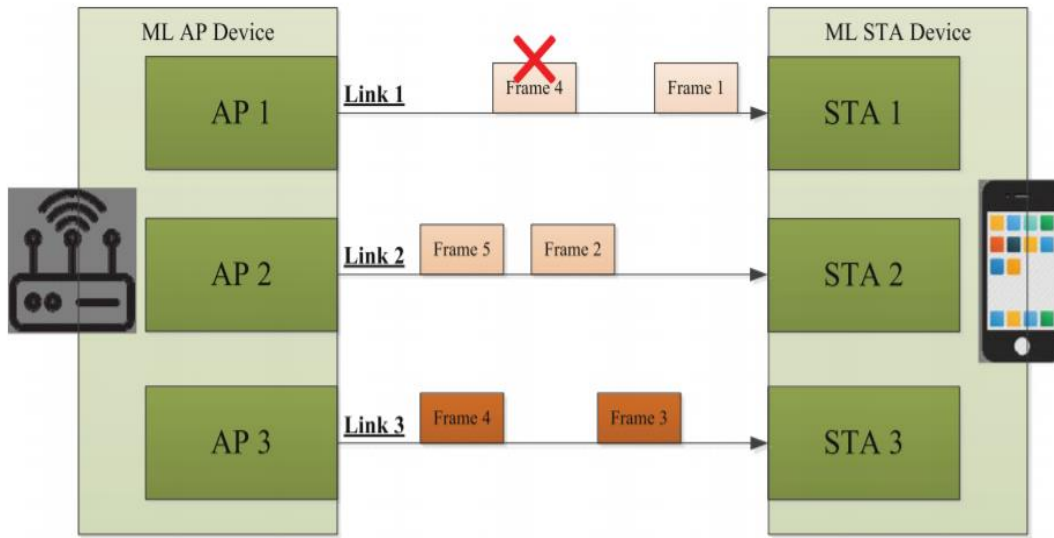

FIGURE 42 : MULTI-BAND/MULTI-LINK AGGREGATION OF IEEE 802.11BE

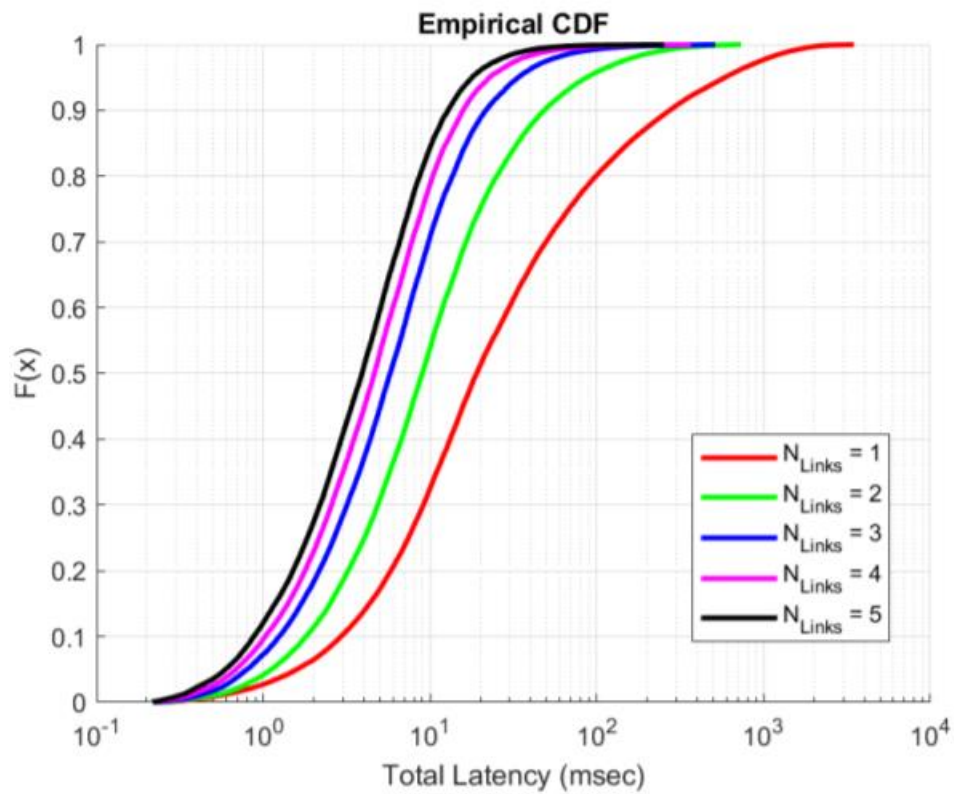

FIGURE 43 : DISTRIBUTION OF LATENCY WITH MLA

Generally, there are two types of ML aggregation named synchronous and asynchronous aggregation as show in Figure 44. [30]

- a) The synchronous ML aggregation means the different links must transmit and receive simultaneously. This type is most suitable for the APs or STAs that cannot support simultaneous transmission and reception, called non-STR capability, due to the adjacent channel interference problem.
- b) The asynchronous ML aggregation means different links can transmit and receive independently, called STR enabled.

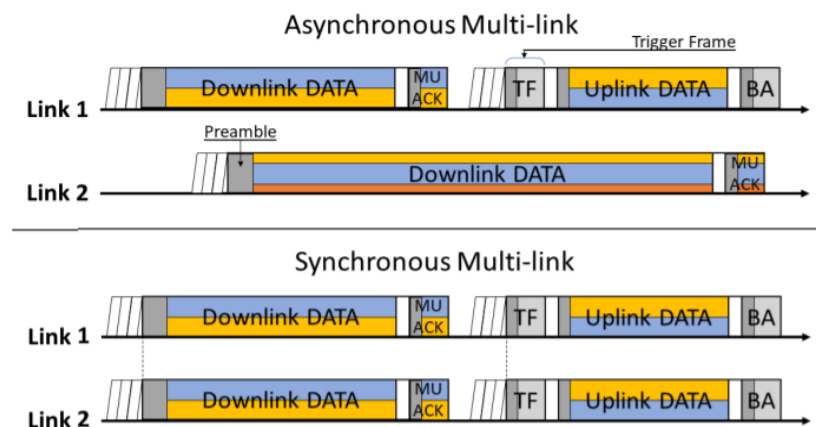
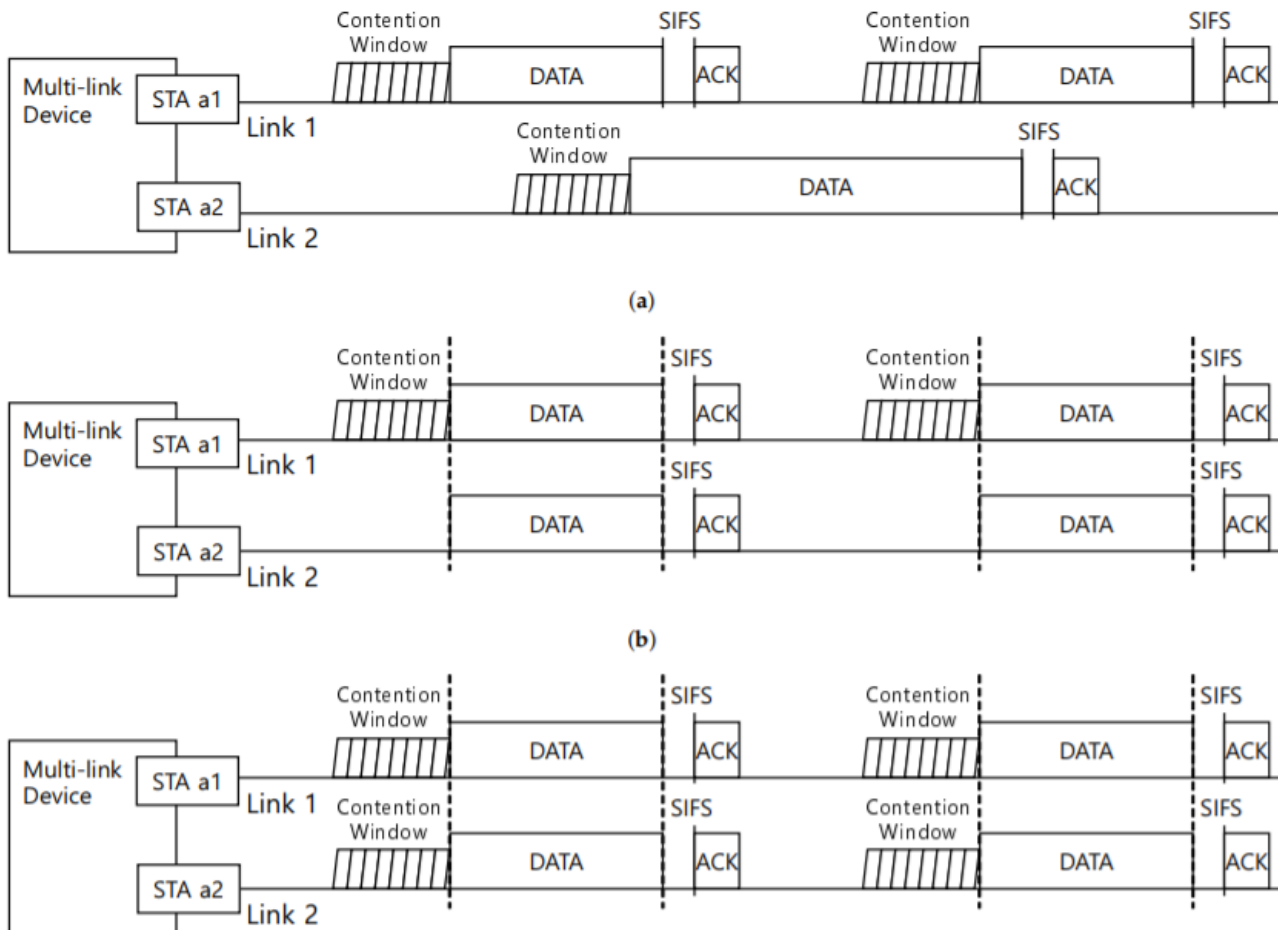

FIGURE 44 : . ASYNCHRONOUS (TOP) VS. SYNCHRONOUS (BOTTOM) MULTI-LINK OPERATION

#### 4.5.1.1 ASYNCHRONOUS VS. SYNCHRONOUS TRANSMISSIONS ON MULTI-LINK

We can sort synchronous transmission into two way: With a single access link & with multiple accessing links. The asynchronous transmission have the classic channel access mechanism in legacy IEEE 802.11, while asynchronous transmission is changed to support the case of non-STR in a multi-link interface.[30]

Figure 45 shows three examples of the multi-link transmission methods.



**FIGURE 45 : ILLUSTRATIVE EXAMPLES OF MULTI-LINK TRANSMISSION. (A) ASYNCHRONOUS MULTI-LINK TRANSMISSION, (B) SYNCHRONOUS MULTILINK TRANSMISSION WITH A SINGLE ACCESSING LINK, AND (C) SYNCHRONOUS MULTI-LINK TRANSMISSION WITH MULTIPLE ACCESSING LINKS.**

Truly, asynchronous transmission, shown in Figure 45A, is approved to be authoritative in IEEE 802.11be. When the MLD is under the STR condition, this means that the stations with the same MLD can transmit and receive frames at the same time in a distributed manner. As a result, each station on the same MLD can implement a medium access process by the links regardless and in an autonomous way. Therefore, asynchronous multi-link transmission can be considered as two independent classical channel access unless the MLD has saturated traffic, like dual/tri-band AP operations in today's.

On the other hand, if the MLD is under the non-STR condition, this means transmission and reception cannot take place at the same time. By aligning of ending times of transmission with the same MLD, like Figure 45B,C, transmission at the same time can be avoided. An open issue is how we can organize an synchronized access channel.

As shown in Figure 45B, there could be a single access link that can perform channel access. In this method, only one link will be set as the channel access link, and so there is a contention window that exists on the channel access link. MLDs and single-link stations will have the same opportunity to access the channel. As a result, a channel will be distributed to both MLDs and to single-link stations. Of course, the throughput in network at the multiple access links will be poor.

On the other hand, as shown in Figure 45C, channel access can be multiple links. Unlike synchronous multi-link transmission with a single access link, all the stations with the same MLD can take place in the channel access into each contention window. That means MLDs will have double access to wireless media.

So far, it is under discussion to find a design point in the media given gains over the standard single-link environment while ensure the channel access opportunity to legacy devices in the same BSS [30].

#### **4.5.1.2 MULTI-BAND MANAGEMENT**

The management function is an important task of IEEE 802.11, which play important role in the availability and efficiency of WLAN. IEEE 802.11be launch more detailed multiband operation, so it will include how to efficiently interoperate between multiple bands, such as multi-band authentication ,multi-band scanning, multi-band association, multi-link setup and update, exchange status information and rapid traffic stream migration. [31]

#### **4.5.1.3 MULTI-LINK AGGREGATION ENHANCEMENT AT MAC**

As described one of the EHT TG target is to satisfy high-throughput and stringent real-time delay requirements of 4K/8K video, AR and VR, online gaming, etc. The Multi-link operation to meet these PAR requirements is becoming a hot topic that discussed by the EHT. There is a new trend that STAs are moving to parallel dual-band / tri-band architectures aggregated in 2.4 GHz, 5 GHz and 6 GHz bands, which requires new management specifications and multiple bands use rules. The main IEEE 802.11 protocol recommends two architectures multi-band MAC to look at different technical support for multi-band operations, namely Independent MAC (non-transparent FST) and Distributed MAC (transparent FST) as shown in Figure 46.



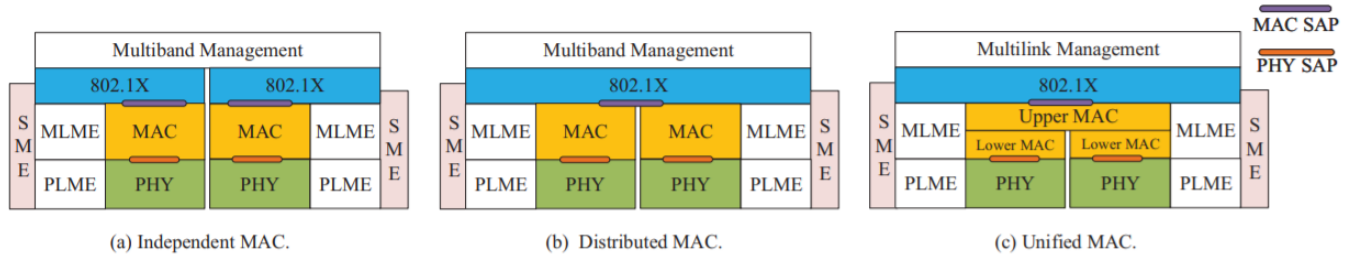

**FIGURE 46: TWO MAC ARCHITECTURES FOR MULTI-BAND AND AN ENHANCED MAC ARCHITECTURE FOR MULTI-LINK AGGREGATION. (A) INDEPENDENT MAC FOR MULTI-BAND. (B) DISTRIBUTED MAC FOR MULTI-BAND. (C) UNIFIED MAC FOR MULTI-LINK**

Both architectures can supply a repetitive transfer of a renegotiation session from one channel to another in the different or same frequency bands.

However, there is a limit that MSDUs belongs to single TID can only use a single band and/or channel, resulting in significant MAC cost for renegotiations. For example, when you change sessions by legacy FST, STAs must initiate the FST Setup Request and Response frame exchanges as well as the FST Ack Request and Response frame exchanges, as a result in important MAC overhead for renegotiation.

To take away the need for multiple management/data plane negotiations for fast session transfer, a substantial MAC upgrade of the new architecture MAC (named Unified MAC for multi-link) [32] in Figure 46 should be that MSDUs belongs to single TID or different TIDs able to transmit to multiple bands and/or channels at the same time or not at the same time.

At the architecture of Independent MAC, different MAC service access points (SAPs) are showed to the upper layers as different MAC addresses are used before and following an FST, and upper layers are guilty for the management of the session transfer to balance traffic load between different bands/channels.

Since the operation of the multi-band management entity is limited to coordinating the installation and collapse of an FST without access to other local information of station management entities (SMEs), local information of an SME, such as robust security network associations (RSNAs), security keys and packet number (PN) counters, must be reset for the new band/channel. In architectures of the Distributed MAC, only one MAC SAP grant by the same MAC address is displayed at the upper layers, causing the higher layers to ignore session transfer between different bands/channels.

The local information of each SME can be shared between many bands/channels, including block ack (BA) agreements, traffic streams, RSNA, association state, PN counters and security keys. In the Unified MAC architecture, it contains only one sub-level MAC management entity and one sub-level MAC.

Unlike the Distributed MAC and Independent MAC, the MAC protocol stack is divided into higher MAC that supports most MAC operations (A-MSDU aggregation/de-aggregation, encryption/decryption, sequence/packet number assignment, integrity protection/check, and fragmentation/defragmentation) and Lower MAC that supports a small number of MAC functions (MPDU heading and cyclic redundancy check (CRC) creation/validation and MPDU aggregation/de-aggregation).

In addition, the Unified MAC can support the dynamic transfer of a TID between multiple links. The traffic is queued and uses all or part of the available channels for transmission at the same time or not.[29]

#### **4.5.2 ENHANCEMENTS OF SPATIAL STREAMS AND MIMO**

To meet this growing traffic requirements created by the growing number of WIFI devices, APs have continued to increase the number of antennas and better spatial multiplexing capabilities over and over the years. In IEEE 802.11ax, an AP has 8 antennas and can serve up to 8 users for uplink (UL)/downlink (DL) transmission at the same time, with MU-MIMO. With continues and the upgrades the AP spatial multiplexing capability, EHT make a propose that the maximum spatial streams by 16 to obtain higher network capacity.

### 4.5.3 MULTI-AP FEATURES

Multi-Ap refers to a set of features that based on direct AP coordination to achieve the desired network performance goals.

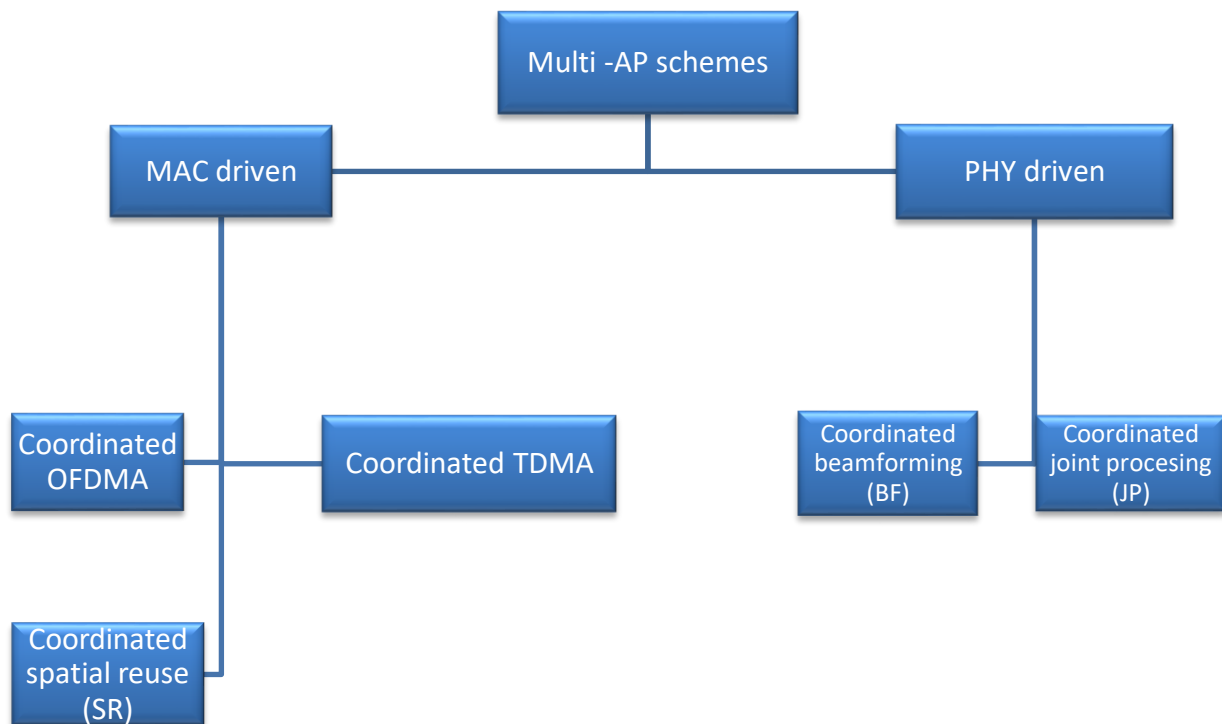

FIGURE 47 : MULTI AP SCHEMES

IEEE 802.11ax can only supports single to - from AP transmission and spatial reuse between APs and STAs without coordination between the neighboring APs. To improve this phenomenon, EHT extend its ability to support sharing data and information control between APs by wireless or wired links, thus improving the performance of spectrum, and maximize the throughput and the reducing of latency.

This important characteristic that can is different in EHT from IEEE 802.11ax is named as Multi-AP coordination, which can be split into coordinated spatial reuse (CSR), coordinated orthogonal frequency-division multiple access (C-OFDMA), coordinated beamforming (CBF) and joint transmission (JXT) according to different coordination complexity. [33]

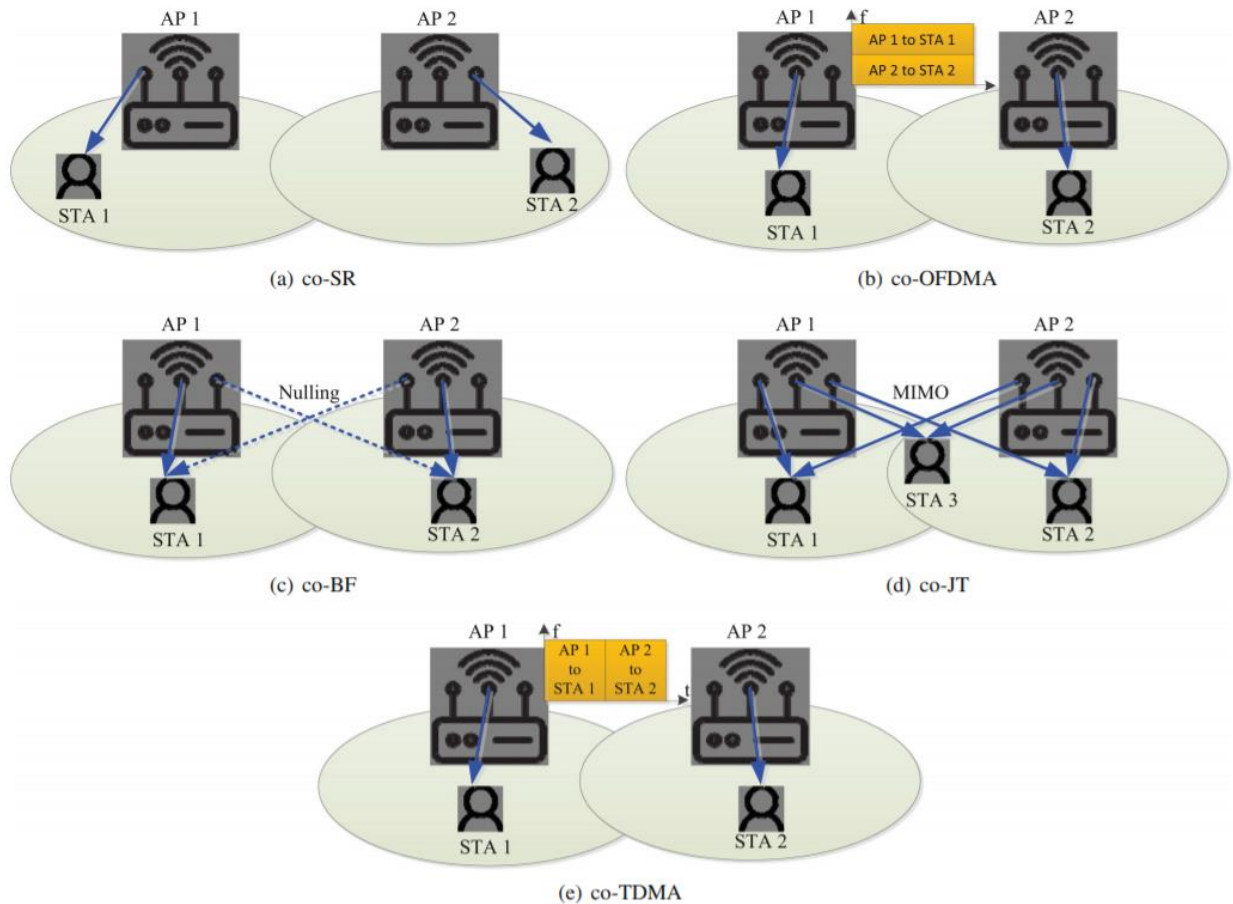

FIGURE 48 : MULTI-AP COORDINATION OF IEEE 802.11BE

#### 4.5.3.1 COORDINATED SPATIAL REUSE (CO-SR)

Co-SSR is the simplest Multi-AP system, is a development of a spatial reuse scheme (SR) that introduced in 802.11ax. It able to used when inter-BSS interference is weak, not to strong , but the channel state is considered busy.

In Figure 48a, co-SR refers to downlink (DL) transmission or uplink transmission to their own STAs on the same channel by information exchange and multiple APs trading. Since Co-SR don't use ordinary MIMO, there is interferences between multiple links. To put down interference, the interaction information between APS is required to obtain that the interference between the two links is accepted. As shown in the Figure 48a, AP1 sends DL data to STA1 on its left side, while AP2 sends data to STA2 on its right side.

The interference between these two links is gentle, so data of both links can be obtained successfully.

#### 4.5.3.2 COORDINATED OFDMA (co-OFDMA)

The multi-AP Co-OFDMA system allows APs to coordinate the schedules on time and frequency. With Co-OFDMA, close APs can allocate the same RUs to some STAs if such transmission does not interfere, or they can assign different RUs to avoid interference. Opening simulation results show that Co-OFDMA is effective for medium or high AP density.

UL and DL OFDMA were introduced by IEEE 802.11ax. As shown in Figure 48b, co-OFDMA relates to a master AP that has successfully accessed the wireless channel coordinates with other APs called slave AP and allocates frequency resources to each other. After that, the master AP and the slave AP send DL data or at the same time schedule UL transmission by using OFDMA. Each AP takes a part of resource units (RU). The advantage of co-OFDMA is that we have no interference between multiple links in theory.

As shown in Figure 48b, AP1 sends data to R1 to STA1 and AP2 sends data in RU2 to STA2 while using OFDMA at the same time. Among the list of multi-AP coordination types, CSR & Co-OFDMA are the more likely to be supported in the new generation due to their flexibility, simplicity, and to other possible solutions.

#### 4.5.3.3 COORDINATED BEAMFORMING (co-BF)

Coordinated beamforming or Null Steering as it is otherwise called, the idea of Co-BF is that while it forms the beams in the STAs, an AP also has the purpose to cancel its interference to particular neighboring STAs.

The Interference Cancellation per AP is an approach of a null steering but is for UL transmission. Before UL frame reception, each AP collects information about the channel to all the near STAs. Subsequently the AP modulates its receiver to obtain a frame from the STA and ignore interference induced by other STAs. This approach does not require no data exchange between APs. It also allows transmission at the same time of different STAs to respective APs.

The co-BF in Figure 48c relates to a master AP that has successfully accessed the wireless channel coordinates with other slave APs. After that, both master AP and slave AP send DL data to their own STAs with MIMO. As we can see in Figure 48c, AP1 and AP2 serve STA1 and STA2 respectively with MIMO. Due to the MIMO use, the interferences in theory have been eliminated in AP1 to STA2 and AP2 to STA1.

#### **4.5.3.4 COORDINATED JOINT TRANSMISSION (CO-JT)**

Co-JT also called Distributed MIMO (D-MIMO), as we can see in Figure 48d. Co-JT refers to a master AP that successfully accesses wireless channel coordinates with other slave APs. All antenna resources from multiple APs and all users from multiple BSSs gathered up together. Then, both master AP and slave AP send DL data to multiple STAs with MIMO. Noting that co-JT allows AP to serve OBSS STAs and allows multiple APs to serve the same STA. In Figure 48d, AP1 and AP2 pull-through antenna resources together and serve all STA: STA1, STA2, STA3 from the two BSSs with MIMO.

#### **4.5.3.5 COORDINATED TDMA (CO-TDMA)**

The Coordinated time division multiple access, as shown in Figure 48e, is related to a master AP that has successfully accesses the wireless channel coordinates with other slave APs to share the transmission opportunity (TXOP). Otherwise APs balance their own AP UL/DL transmission at different time period in the TXOP as shown in Figure 48e, at the same TXOP, AP1 place DL transmission followed by AP2. In a typical multi-AP network architecture (like business network) with no central node, an AP must communicate with each neighboring AP for coordination, which will result in substantial over signaling and processing complexity. Therefore, requires an efficient coordination procedure (including the multi-AP selection, multi-AP transmission and the multi-AP sounding) with low overhead and processing complexity to support all the multiples AP coordination types. In addition, accurate phase/time synchronization and proper resource allocation functions are crucial to avoid interference between neighboring APs, as no complete synchronization can cause important maximum throughput breakdown. [33]

#### **4.5.4 HARQ**

Hybrid Automatic Repeat Request (HARQ) is another possible feature that have been discussed for EHT, that can combine pre-decoding retransmissions for the performance improvement by reducing the latency and increasing the reliability.

The nowadays Wi-Fi systems are based and designed on the retransmission of MAC protocol data units (MPDUs) that means when they are not successfully decoded at the receiver or an acknowledgement (ACK) its not received at the transmitter. With this approach of Automatic Repeat Request (ARQ), the receiver refuse the failed MPDU before its retransmitted version is taking, thus not allowing smooth combining.



#### 4.5.5 NON-ORTHOGONAL MULTIPLE ACCESS

The NOMA method is designed to increase the maximum throughput and improve efficiency. The basic idea of NOMA is that an AP can serve multiple STAs at the same time in the same baseband by assigning portions of the total transmit power for each STA (Figure 50).[28]



FIGURE 50 : THE CONCEPT OF NOMA

The AP can implement NOMA transmissions by encoding overhead, that is a simple overlay of multiple signal components with different rates subject to a power limitation. Therefore, the higher the power, the more reliable is the element reception. In the case of two-STA , the high-power element is intended to a far STA with conditions of worse channel, while the other component is intended for a nearby STA.

The far-off STA receives the composite signal, interference perceived from low-power component as noise. The proximal STA separates the data signal elements using successive interference constellation (SIC).

This proposal introduces a variation of NOMA: Semi-orthogonal Multiple Access (SOMA). SOMA not only superimposes but creates an artificially designed gray-mapped constellation.

This feature makes the low power signal element more resistant to noise. In addition, SIC becomes redundant, which makes the receiver less complicated. The NOMA/SOMA implementation indicates that can be compatible with the past:

The far STA may be legacy. Because STA receives the signal as it is and does not apply SIC, you do not need to know that the composite signal using SOMA.

NOMA technology is not striving against MU-MIMO, but maybe complementary.

MU-MIMO has a high performance if the STAs have the same attenuation but orthogonal MIMO channels. Instead, the NOMA works best with the STAs that have different attenuation and associated channels. [28]



#### 4.5.6 THE CHANNEL SOUNDING

The MU-MIMO is a main technique used in many wireless network technologies for the capacity increase. For this technique require strict knowledge of the channel condition. The 802.11ax sounding procedure consists of sending a reference signal from the AP and receiving specific channel state information (CSI) from the STAs.

The process starts with a Null Data Packet (NDP) Announcement (NDPA) sent by the AP to alert the STAs of the following reference signal. The AP sends this signal a short inter-frame space after NDPA in the form of Null Data Packets (NDPs). Shortly inter-frame space after NDPA, the AP broadcasts an NDP, which used by the STAs to estimate the channel.

In NDP there is a HE-LTF3 of duration 7.2, 8, or 16 us for each SS.

By receiving the NDP, the STAs reply with the beamforming Reports (BFR) either sequentially or in parallel thanks to OFDMA.

The Information from BFR provides :

- The SNR average of each SS. Each SNR is an 8-bit integer.
- The rotation angles ( $\phi, \psi$ ) of the matrix feedback, for every 4th or 16th subcarrier. The size of a  $\phi$ - $\psi$  pair is 6 or 10 bits for a single user and 12 or 16 bits for MU.
- For MU-MIMO, an array of 4-bit is different between the SNR for subcarrier and the average SNR in the SS.

Taking into the BFR, the CSI for the other subcarriers is inserted. So, for a 160 MHz channel, an SS, and every 16th subcarrier being mentioned, BFR contains information about 128 subcarriers. For a larger number of SSS, also increasing the size of both the NDP and BFR. For example,  $4 \times 4$  MIMO requires just six pairs of  $\phi$  and  $\psi$  angles per subcarrier, whereas  $8 \times 8$  MIMO requires 28 pairs, and  $16 \times 16$  MIMO requires 120 pairs.

Wi-Fi 7 support up to 16 SSS, such a high order of MU-MIMO and wider channels twice actually and that make a huge overhead (Figure 51).

As the process takes up to 10 ms, the channel measurements are made useless, as the channel varies important between the NDP and the next data transmission. So, the measured channel state becomes old. The main challenge by increasing the MIMO is to reduce of the overhead induced by channel sounding and BFR. As this challenge is extremely important for Wi-Fi 7, many ideas are proposing with different approached how to reduce overhead. [28]

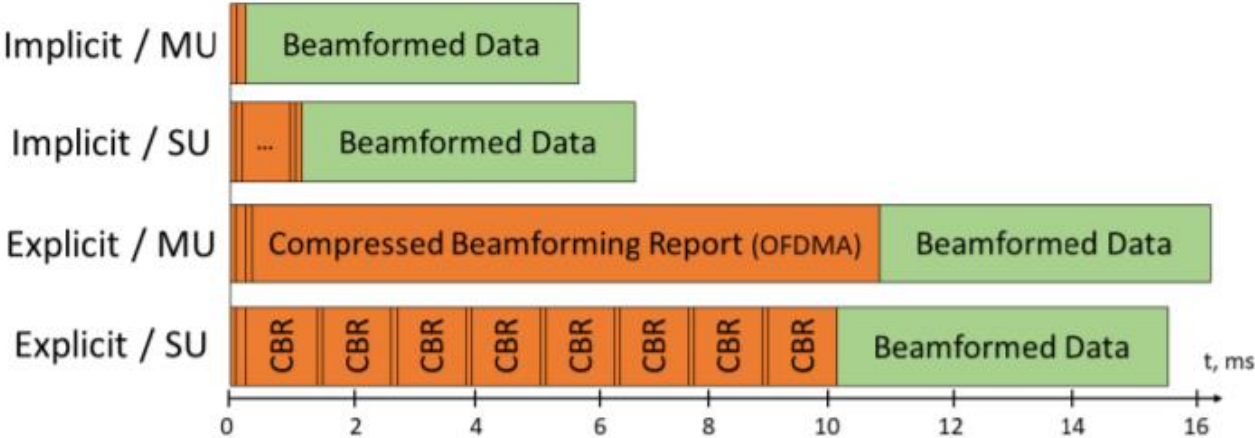

FIGURE 51 : DATA TRANSMISSION VS SOUNDING AND FEEDBACK OVERHEAD COMPARISON, NR = 16, NC = 2, NUSERS = 8

#### 4.6 PHYSICAL ENHANCEMENTS FOR EHT

To support high-throughput and low-latency video applications such as VR, AR and online gaming, EHT introduces some Physical enhancement technologies shown in Figure 52, with purpose of EHT to perform Extremely High Peak rate of up to 30 Gbps as reported by the IEEE community.

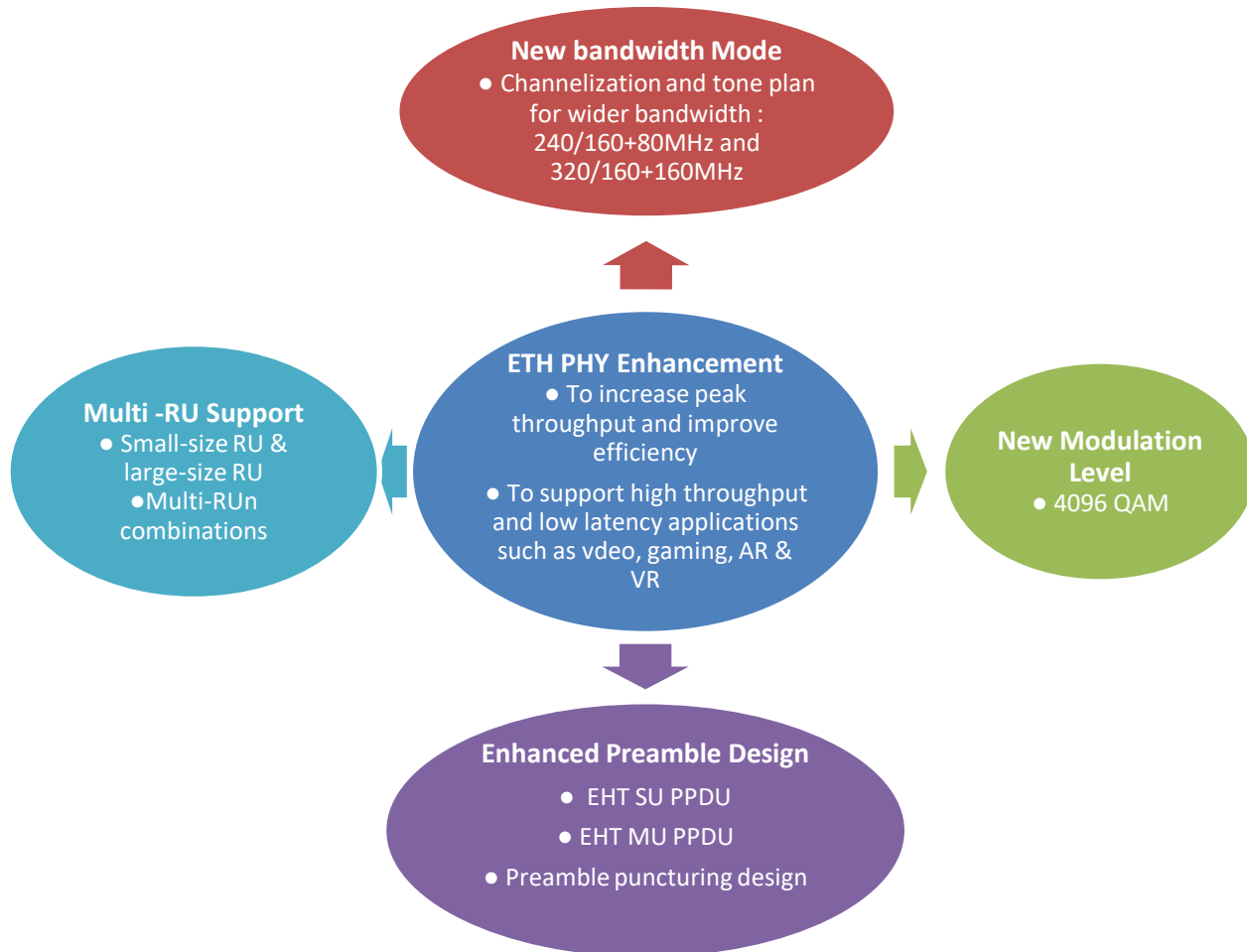

FIGURE 52 : PHY ENHANCEMENTS FOR EHT

PHY enhancements and related works are summarized in Table 7 [29].

PHY Enhancement	Contributions
New Bandwidth Mode	Forward way on IEEE 802.11be specification development for 6 GHz band support
	Discussion on multi-band operation, flexible channel aggregation
	Channelization of 320 MHz, EHT PPDU bandwidth modes and EHT tone plan designs for 320 MHz
Multi-RU Support	Maximum number of RUs assigned to a single STA and restrictions on the combination and locations of RUs
	Discussion on several aspects regarding multiple RUs for one user transmission: PPDU format, transmission in Data field and signaling
EHT Preamble Design	Three phase rotation design options for 320 MHz: repeat IEEE 802.11ax/new phase rotation, repeat IEEE 802.11ax/new phase rotation and apply additional phase rotation, and find optimal phase rotation
	Preamble structure designs
	EHT P matrices design for EHT-LTF and the new considered dimension of P matrix
	EHT-LTFs design considerations: EHT-LTFs reuse HE-LTFs in 20/40/80/160/80+80 MHz PPDU for considering backward compatibility, while EHT-LTFs in 320/160+160/240/160+80 MHz PPDU pay more attention to EHT-LTFs design methods with low peak to average power ratio and low overhead
	Proposals for forward compatibility as a requirement for IEEE 802.11be preamble
	Extending IEEE 802.11ax preamble puncturing patterns up to 240/320 MHz
	Simulation of the channel utilization gain when using a more effective channel puncturing than is used in IEEE 802.11ax
Higher-Order Modulation Schemes	Feasibility analysis of 4096-QAM in certain configurations, including using transmitting beamforming, low number of streams and strict receiving EVM requirement or multiple receiving antennas

TABLE 7 : SUMMARY OF PHY ENHANCEMENTS AND RELATED WORKS.

#### 4.6.1 NEW BANDWIDTH MODE

A much higher gain is possible by doubling the bandwidth. Recently opened for ISM usage, the 6 GHz band offers hundreds of MHz available to WIFI. To take advantage of these frequencies, TGbe introduces the 320 MHz channels, which can double the maximum throughput with respect to 802.11ax.

In addition, this feature improves actual data rates if the distance between the transmitter and the receiver is moderate, as the achievable rate increases with the bandwidth, while the effect from twice smaller SNR is logarithmic.

In Figure 53 the maximum permissible transmission bandwidth over 2.4 GHz and 5 GHz frequency bands are 40 MHz including of two continuous 20 MHz and 160 MHz including of two continuous/discontinuous 80 MHz, respectively, which cannot get together the requirements of high-throughput and low-latency services, like 4K/8K video, VR or AR and online gaming. The new trend of 6 GHz band, such as bandwidth up to 320 MHz, will help success of EHT target: **A maximum throughput at least 30 Gbps.**

The 320 MHz bandwidth may be continuous and in the same 6 GHz band or noncontinuous and located in different bands (5 GHz // 6 GHz band). Below the existing BW rule of extension in WLAN, the 320 MHz bandwidth can be decomposed into two discontinuous 160 MHz bandwidths which are found out at 5 GHz and 6 GHz bands, respectively.

In the first discussion, it was agreed that only continuous 240 MHz, non-continuous 160+80 MHz, continuous 320 MHz and non-continuous 160+160 MHz, are supported as new bandwidth modes for EHT.

For the new 320 MHz//160+160 MHz bandwidth, EHT should support the double IEEE 802.11ax 160 MHz tone plan for the OFDMA tone plan. With the EHT preamble pending, the tone plan for non-OFDMA 320 MHz//160+160 MHz is under discussion.[29]

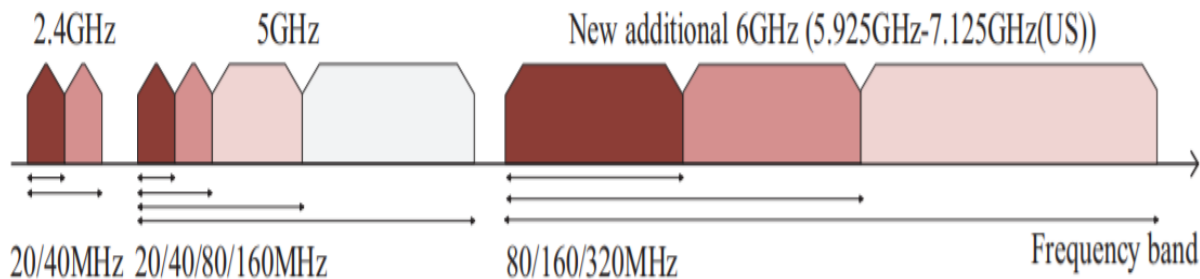

FIGURE 53 : AVAILABLE TRANSMISSION BANDWIDTH OVER 2.4 GHZ, 5 GHZ AND 6 GHZ FREQUENCY BANDS.

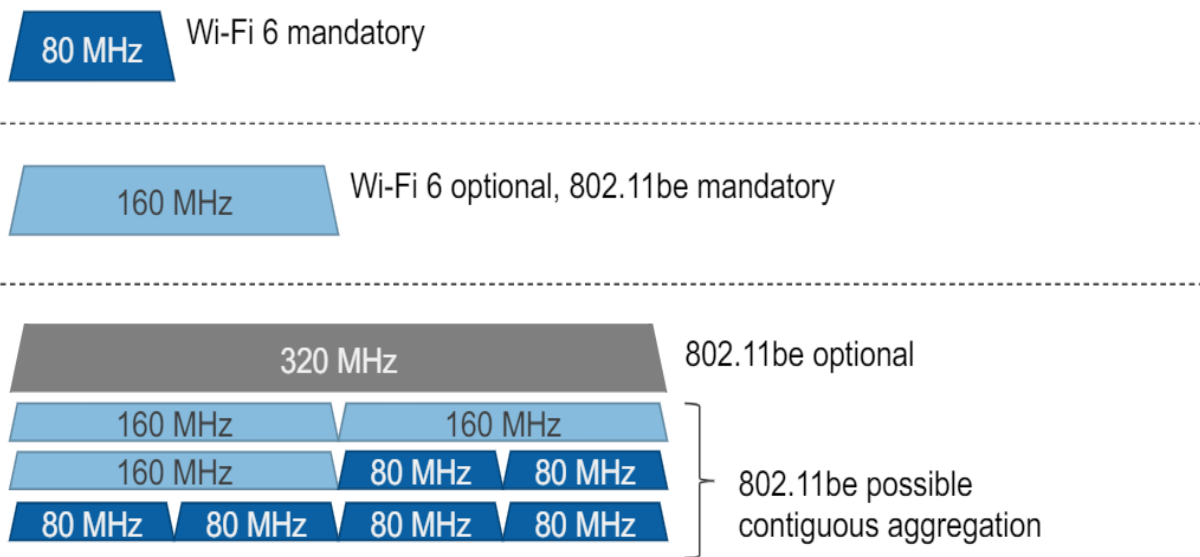

FIGURE 54 : BANDWIDTH MODES FOR EHT

#### 4.6.2 SUPPORT MULTI RU

In IEEE 802.11ax, the RUs defined for DL and UL transmission are as follows: 26 tone RU, 52 tone RU, 106 tone RU, 242 tone RU, 484 tone RU, 996 tone RU and  $2 \times 996$ -tone RU. To improve the spectral efficiency, the notion of multiple RUs to be assigned to a single user and new  $3 \times 996$ -tone RU has already approved by the task group of EHT.

To achieve the trade-off between spectral efficiency and combination complexity, we can use some limited multi-RU combinations that is allowed for the case with the bandwidth less or equal to 160 MHz, small-size RUs (that is less than 242 tones) can only be combined with small size RUs and large size RUs (that is more than or equal to 242 tones) can only be combined with large-size RUs, but the mix of small-size RUs and large-size RUs it is not allowed.

Table 8 shows the multi-RU combinations for different bandwidth modes in EHT, that means the combination of small size RUs would not cross 20 MHz channel border and the combination of 26-tone RU and 52 tone RU for 20/40/80 MHz PPDU format and the combination of 26 tone RU and 106 tone RU for 20/40 MHz PPDU format be allowed.

The permitted large size RU combinations are 242 tone RU + 484 tone RU for 80 MHz OFDMA/non-OFDMA PPDU format and 484 tone RU + 996-tone RU for 160 MHz OFDMA/non-OFDMA PPDU form. In IEEE 802.11ax, OFDMA only supports 2/4/8/16 users, while in EHT the multi-RU support could allow more flexible support for other numbers of users values, like 5 or 6 users, and can allow up to 3 RUs to suggested to a single user. However, so far, the EHT task group has not achieved a consent on the max number of RUs assigned to a single user. [29]

Type	Definition	Allowed Combinations
Small-size RU	26-tone, 52-tone, 106-tone	- 26-tone RU + 106-tone RU for 20/40 MHz - 26-tone RU + 52-tone RU for 20/40/80 MHz
Large-size RU	242-tone, 484-tone, 996-tone, $2 \times 996$ -tone, $3 \times 996$ -tone ( <i>new additional</i> )	- 242-tone RU + 484-tone RU for 80 MHz - 484-tone RU + 996-tone RU for 160 MHz, 242-tone RU + 484-tone RU + 996-tone RU for 160 MHz - 484-tone RU + $2 \times 996$ -tone RU for 240 MHz, $2 \times 996$ -tone RU for 240 MHz - 484-tone RU + $3 \times 996$ -tone RU for 320 MHz, $3 \times 996$ -tone RU for 320 MHz

TABLE 8 : MULTI-RU COMBINATIONS FOR DIFFERENT BANDWIDTH MODES IN EHTRE

### 4.6.3 PREAMBLE DESIGN OF EXTREMELY HIGH THROUGHPUT

By the development procedure of, each standard WLAN is particular preamble, that gives functions that include channel estimation , auto-detection , synchronization and the necessary signaling. Same to IEEE 802.11ax, to support the different technologies and scenarios, EHT should set at least a new preamble format for the possible PPDU formats, just as EHT SU PPDU, EHT Trigger-based PPDU, EHT ER (extended range) SU PPDU and EHT MU PPDU.

In Figure 55 we can see, an EHT PPDU with a legacy part field (named non-HT Short Training field (L-STF), legacy SIG field (L-SIG) , legacy LTF field (L-LTF), and repeat legacy SIGNAL field (RL-SIG)), a universal SIG (U-SIG) field, an EHT Short Training field (EHT-STF), an EHT-SIG field, an EHT Long Training field (EHT-LTF) and a Data field.

So, to keep the compatibility of the backward with the legacy PDUs operating in 2.4 GHz, 5 GHz, & 6 GHz bands, the part of legacy field should be operate to the beginning of the EHT PPDU, that is using for synchronization , frame detection, and to carry the necessary information (like MCSs and frame length).

For a PPDU with a bandwidth of 160 MHz or less, the old part is copied and can reuse the existing tone rotation. Therefore, for a PPDU with a bandwidth of 160 MHz and wider, the rotation of tone is still not determined.

To outsmart IEEE 802.11ax devices and with respect in the length in the L-SIG field, the first symbol after L-SIG must be with modulation of BPSK in an EHT PPDU.

For the improvement of the robustness in L-SIG in outdoor scenarios and know the EHT PPDU through an automatic detection, the RL-SIG field is needful and must be different from the RL-SIG field in the IEEE 802.11ax PPDU.

Attendant the RL-SIG field, the EHT PPDU includes a two OFDM symbol U-SIG field like the HE SIGNAL A (HESIG A) in IEEE 802.11ax, that is used for carrying the needful information for the explanation of EHT PDUs.

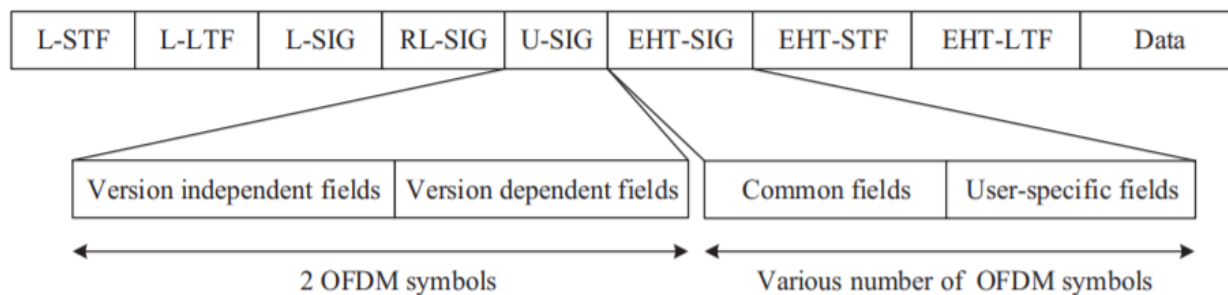

FIGURE 55: THE EHT PPDU FORMAT



To support an effective signaling for an EHT PPDU sending to multi users, like the OFDMA and DL MU-MIMO resource allocation information, it can be a changeable MCS and variable-length EHT-SIG field (at once after the U-SIG) in an EHT PPDU.

The EHT-SIG field contained of common fields or zero or several user-specific fields. The standard field contains information about MCS, coding, RU allocation, the number of space-time streams, the duration of the GI.

The user specific fields carry dedicated information for individual users. For the SU PPDU the EHT-SIG field is composed of only the common field part without user-specific fields. At the EHT Trigger based PPDU, if we can include all information in the U-SIG field, the EHT-SIG is skipped.

The EHT LTF field and EHT STF field, the last field of the EHT preamble, gives a field for users for estimation the channel of MIMO, and EHT of course could support three types of EHT-LTF : **1- EHT LTF, 2-EHT LTF and 4- EHT LTF.**

Besides, in reusing HELTFs for EHT-LTFs in 20//40//80//160//80+80 MHz EHT PPDU is recommended and the methods of designing that proposed for EHT-LTFs in 240//160+80//320//160+160 MHz EHT PPDU.

To solve this problem of more and more complex preamble formats, the key is to minimize the designing load and limitation the complexity while keeping compatibility forward with IEEE 802.11 future generations.

An effective approach is a Preamble puncturing to enhance the channel utilization and for improving the transmission rate. With the wider bandwidth than 160 MHz in EHT, preamble puncturing will request more complicated hardware operations and more flexible preamble puncturing patterns, expanding IEEE 802.11ax preamble puncturing patterns up to 240//320 MHz or apply the puncturing to primary channels for increasing the opportunities of channel access. [29]

#### 4.6.4 HIGHER-ORDER MODULATION

For more improvement of the peak rate, when a comparison is made with IEEE 802.11ax that high order modulation is 1024 QAM, a higher order modulation that has been discussed and suggested in WIFI 7 is 4096 QAM, where a modulation symbol can carry 12 bits.

In theory, since the same coding rate, WIFI 7 can support 20% higher transmission rate entering into comparison with WIFI 6, thus enabling its users to achieve higher transmission efficiency while required higher EVM.

The first simulation results show that applying 4096 QAM is possible in some configurations, such as using transmitting beamforming, strict EVM requirement, low number of streams, and multiple receiving antennas.

To accept 4096 QAM the SNR is needed at the receiver side with about 40 dB, which is too high for a typical WIFI scenario. Such a high SNR can be achieved with beamforming. So, this modulation can be fruitful in the case that AP has several antennas and serves only one client STA with a few antennas. In such a case, MU transmissions cannot be used, and the number of SSs is low. Thus, the only way to increase throughput is by using a high order of constellation. That is why 4096-QAM will be optionally supported by EHT. [29]

#### 4.7 SUMMARY OF WI-FI 7

The 802.11be project has imposed very ambitious goals associated to high data rates, better interference decrease, high spectrum efficiency, and the RTA support to provide. To succeed these targets, the 802.11 Working Group has discussed 500 and maybe more proposals from too different areas. **All of this in Wi-Fi 7 we can showed to seven major innovations.**[28]

Innovation \ Target	Nominal Throughput	Interference Mitigation	Spectrum Efficiency	Real – Time Applications
ETH PHY	4096 QAM 320 MHz, 16x16 MU-MIMO		ETH Preamble	
EDCA with 802 TSN Feature				IEEE 802 TSN Faster Backoff, New Access Categories, TXOP capturing
Enhanced OFDMA		Preamble Puncturing	Multi-RU, Direct links	Enhanced UORA
Multi-Link Operation	Multi-link Architecture	Synchronous Channel Access	Virtual BSS	Asynchronous Channel Access Packet Duplication Queue Management Dynamic Link Switching
Channel Sounding Optimization			Implicit Sounding Explicit Feedback Channel Estimation	
Advanced PHY	Full Duplex		HARQ NOMA / SOMA	
Multi – AP Cooperation		Null steering, Co-OFDMA, CSR	Distributed MU-MIMO, Multi-AP Sounding	Joint Reception

TABLE 9 : MAIN INNOVATIONS OF IEEE 802.11BE AND CANDIDATE FEATURES

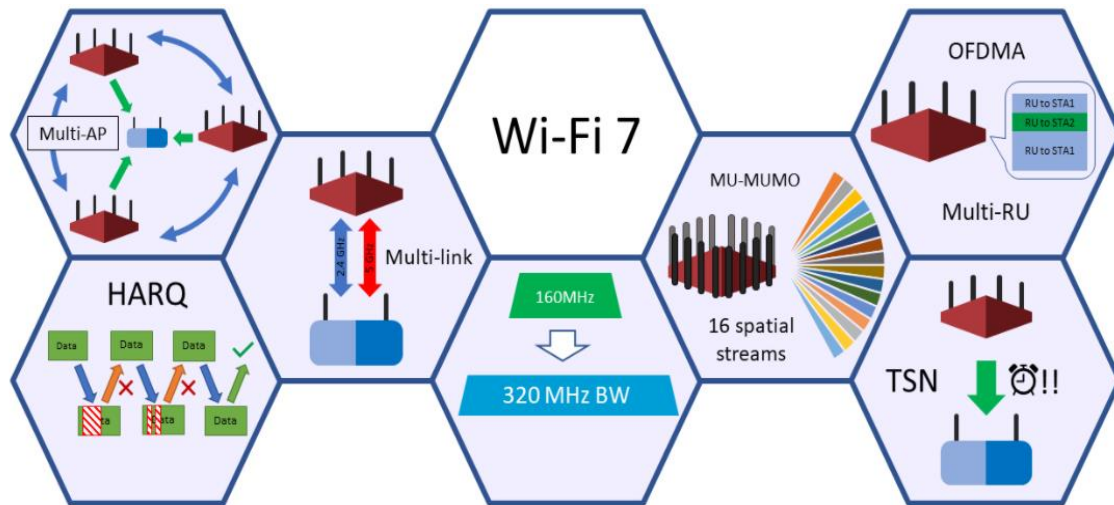

In the next chapter will be studied the IEEE TSN framework and its key components: Time synchronization, traffic shaping and scheduling, ultra-reliability, and resource management.

## 5. TIME-SENSITIVE NETWORKING (TSN)

From the IEEE 802.11 TSN Task Group TSN is a class of standards that defined to support deterministic messages over Ethernet.

In essence, TSN technology is based on a centralized management system using time scheduling to guarantee reliable packet delivery with specific latency and low packet delay variation (jitter) in deterministic real-time applications.

The coexistence of different traffic categories is ensured by two TSN sub-standards:

- IEEE 802.1Qbu applies frame preemption to inhibit any of continuing operation if select a time sensitive frame for transmission.
- IEEE 802.1Qbv is using for creating dedicated time slots for time sensitive frames managed by a time aware modulator.

Careful planning of WIFI 7 technologies considering the TSN authorities could of course help for reducing WIFI latency, but now that possible integration is not simple nor special from incompatibilities and uncertainties.

The approach that TGbe could follow includes both adjustments of TSN sub-standards and proposals of new solutions in various areas, as gather in Table 10.

This section describes the traffic shaping and time synchronization and scheduling components of TSN, we analyzing the most suitable enhancements of IEEE 802.11be to support them, highlights the key challenges participate in the process of integration, and we see some of the possible solutions and directions researches.[34]

*To perform the above capabilities, TSN classifies all standards into four main axes:*

- **Time synchronization:** The TSN standard of IEEE 802.1AS including a version of Precision Time Protocol (PTP), that allows the distribution of a single reference clock on all network master/slave devices. The availability of a main clock is also a basic requirement for WIFI 7, as it would allow successful scheduling of MU transmissions in downlink and uplink, as well as to create coordination mechanisms between APs. Indeed, IEEE 802.1AS can already operate through IEEE 802.11 by means of the timing measurement (TM) process defined in IEEE 802.11v, which takes wireless link asymmetric delay into consideration. Time is spread in private action frames between a master (the AP) and a slave (the STA), as he is the last able to calculate the clock offset and adapt its own time accordingly.

Additionally, the next revision of the IEEE 802.1AS standard (IEEE 802.1AS-Rev) it will include the new synchronization method by using the IEEE 802.11mc Fine Timing Measurement (FTM) process. FTM can provide 0.1 ns of time resolution, much more correct than TM, that time resolution is 10 ns.

- **Traffic shaping and scheduling** allows for different traffic types coexisting with competing priorities in the same network by two IEEE standards:
  - IEEE 802.1Qbu applies frame preemption to break through the continued operation of a low priority queue if a time sensitive (preempting) queue selected for the transmission. Moreover, the low priority frameworks are split into smaller sections to longer reduce the total latency.
  - IEEE 802.1Qbv generates TDMA design that split communication time on an Ethernet network into repetitive fixed length cycles. A time aware modulator determines the time period in which time-sensitive frames can be transmitted with the safety and there will be no not interference by other traffic.
- **Ultra-reliability** is responsible of IEEE 802.1CB, which needs the existence of multiple paths between the sender and the receiver. It sends double copies of each frame over shred paths to procure proactive seamless redundancy.
- **Resource management** in the network it called to those policies to manage the available resources (bandwidth, communication paths, scheduling patterns, and so on). From the setted application and the user requirements, IEEE 802.1Qcc implements and a centralized or a distributed approximation. [34]

Table 7 provides a summarized view of TSN enhancements.

Component	Subcomponent	Proposed enhancement	Targeted feature			
			Latency	Jitter	Reliability	Management
Time synchronization		IEEE 802.1AS over IEEE 802.11	x	x		
		IEEE 802.11mc FTM	x	x		
Traffic shaping and scheduling	Traffic identification	Priority tagging with DSCP	x			
	Traffic isolation	Frame preemption	x	x		
Ultra-reliability	Admission Control	Admission control in EDCA and HCCA	x		x	
		Multi-band admission control	x		x	
	Scheduled operation	Time-aware shaper	x	x	x	
		Trigger - based access	x	x	x	
		TWT mechanism	x	x	x	
		PSMP and HCCA	x	x	x	
		Rate adaptation in trigger - based access			x	
		Spatial reuse techniques	x	x	x	
		D-MIMO mechanisms	x	x	x	
		IEEE 802.11ak + frequency diversity			x	
		IEEE 802.11ak + multi-AP transmission			x	
		IEEE 802.11ak + HARQ			x	
	Frame retransmission			x		
	Resource Management	Multi-AP resource coordination				x

TABLE 10 : SUMMARY OF ENHANCEMENTS TO SUPPORT TSN IN WIFI 7 AND THE MAIN FEATURES THEY TARGET.

## 5.1 IMPROVEMENTS TO SUPPORT TIME SYNCHRONIZATION

Through IEEE 802.11 can already operate IEEE 802.1AS by the timing measurement (TM) process defined in IEEE 802.11v, which takes into reason the wireless link asymmetric delay. Time is spread in private frameworks between the master and the slave, being the last able to compute the clock offset and adjust its own time.

Additionally, the next revision of the IEEE 802.1AS standard (IEEE 802.1ASRev) it will include a new synchronization method by using the IEEE 802.11mc fine timing measurement (FTM) process. Fine timing measurement can provide 0.1 ns of timestamp resolution, much more than timing measurement, that timestamp resolution is 10 ns. [35]

## 5.2 IMPROVEMENTS TO SUPPORT TRAFFIC SHAPING AND SCHEDULING

1. Traffic identification: When classifying different traffic streams, the common enhanced distributed channel access (EDCA) form is include in IEEE 802.11e with 4 access categories: 1) best effort 2) background 3) video 4) voice. Nevertheless, EDCA access categories are not good enough for real-time applications.

By the TGbe group one of the mechanisms that has being considering in is the adoption of a modified priority point tag system is based on the Differentiated Services Field Codepoints (DSCP), that use 6 bits for packet sorting in the IP header.

On this mechanism the main disadvantage , is that the priority can keep it on the local network if configuration is in the controller or on edge router, which requires to implement of a traffic identification and classification scheme.

2. IEEE 802.1Qbu frame preemption is considered as a feasible option to isolate time sensitive from background traffic.

Nevertheless, it is still necessary to identify the improvements in the MAC that is able to support this technique, like the format of preemptable frames, the arbitration between the time sensitive and the frames of preamble, and the methods to frames fragment and maintains integrity of preemptable traffic (Figure 57).

3. Admission Control: Admission control systems, where only a set of STAs number are accepted in the basic service set (BSS), can also be applied in IEEE 802.11be in different ways:



- The IEEE 802.11e incorporates new MAC layer QoS schemes and new parameters that allow EDCA and hybrid coordination function controlled channel access (HCCA) for the performing admission control mechanisms that based on network condition measurements (on measurement based) or performance metrics (on model based) for EDCA, and for HCCA in deterministic schemes.
  - Multi-link operation and the incorporation of the 6 GHz band into IEEE 802.11be provide for the appearance of simple multi band input control systems. At 6 GHz access could be restricted band for time sensitive traffic but with no restrictions at 2.4 and 5 GHz bands.
4. Scheduled operation: The transmission of time sensitive and the non time sensitive traffic can perform in periodic time, by the rules of a schedule that can create from any of the following options:
- Adapting the IEEE 802.1Qbv time aware shaper on top of one of the IEEE 802.11 MAC function can resulting in giving by each device a transmission schedule indicating the specific time period for the release packets from the buffers according to their priority (Figure 56).
  - The Trigger based scheduled channel access mode for MU transmissions from IEEE 802.11ax is also at the head of the TGbe group. In particular, two possible directions has been recognized to improve it:
    1. To replace the main trigger frame (TF) with an extensive including timetable information of subsequent time periods.
    2. Reducing the control overhead (specifically in small packets).
  - WIFI 7 also expects to take advantage of the wake time (TWT) mechanism from IEEE 802.11ax to set a wake time schedule for STAs. With wake time, STAs are only allowed to wake up when its necessary, greatly to reduce the overall network contention, thereby facilitating the operation without collision.
  - Finally, though rarely used in the IEEE 802.11 ecosystem, already existing mechanisms such as power-save multi-poll (PSMP) and HCCA could also make deterministic time scheduling.

### 5.3 IMPROVEMENTS TO SUPPORT ULTRA – RELIABILITY

There is a significant reliability gap to overcome in IEEE 802.11, especially given the potential for interference in license-exempt bands.

On this case, the solutions range from traditional rate adaptation mechanisms (selection of lower modulation and codification schemes (MCSs) for time sensitive frames in trigger-based access) to more complex systems targeting at multiplexing transmissions of STAs in the same time/frequency resources (spatial reuse techniques and D-MIMO mechanisms).

IEEE 802.11CB can already be implemented in the wireless domain by means of the IEEE 802.11ak modification, which can create link-disjoint or node-disjoint paths. However, to improve wireless path reliability is necessary to consider other complementary enhancements:

- Use of spectrum diversity either in separated bands (multi-band) or in channels (multi-channel) for simultaneous transmission of multiple copies of the same frame.
- Use of joint transmissions from multiple APs (transmit multi-AP) to increase frame reception probability by improving signal levels at the destination.
- Using HARQ on different channels to overcome spectrum diversity improvements, as it not only ensures reliability, but also provides higher throughput.

Finally, temporal diversity can always be exploited by transmitting the same frameworks many times over time, although at a higher cost of latency. [35]

### 5.4 IMPROVEMENTS TO SUPPORT RESOURCE MANAGEMENT

Enhancements aimed at supporting TSN in IEEE 802.11be should regard normal and managed operation. Normal operation is characterized by the lack of coordination between APs, where unmanaged interference and contention is expected in the targeted scenario (Apartments-homes-buildings, hot spots).

Managed operation on the other hand assumes that all wireless devices belonging to the same management domain are coordinated, thus operating under controlled interference and contention levels. In typical scenarios are indoors (enterprise networks or factories).

The TGbe group aims to develop the necessary coordination protocols and security procedures to enable a managed overlapping basic service set (OBSS) like the one from Figure 57 , where TSN strategies are propagated from the AP coordinator to the coordinated APs, and then in turn to the STAs deployed in the coverage area. This approach, known as multi-AP resource coordination, assumes that all APs are under control of a single entity (the network controller) and interference from unmanaged STAs/BSSs can be minimized through admission control and other management tools.[36]

Therefore, two different types of traffic patterns can be handled simultaneously : predictable time-sensitive and unpredictable best-effort.[35]

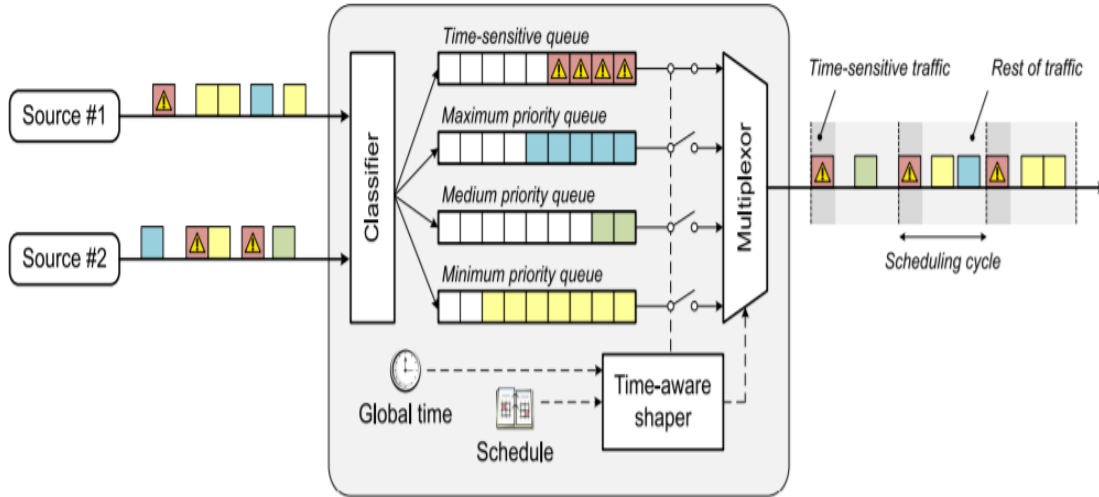

FIGURE 56 : TSN TRAFFIC SHAPING AND SCHEDULING

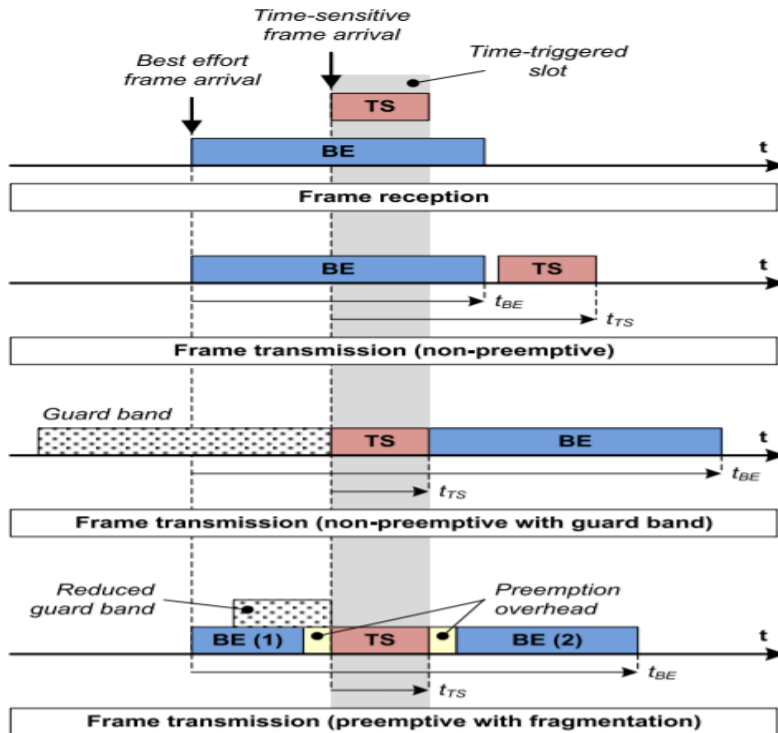

FIGURE 57 : TSN FRAME PREEMPTION MECHANISM

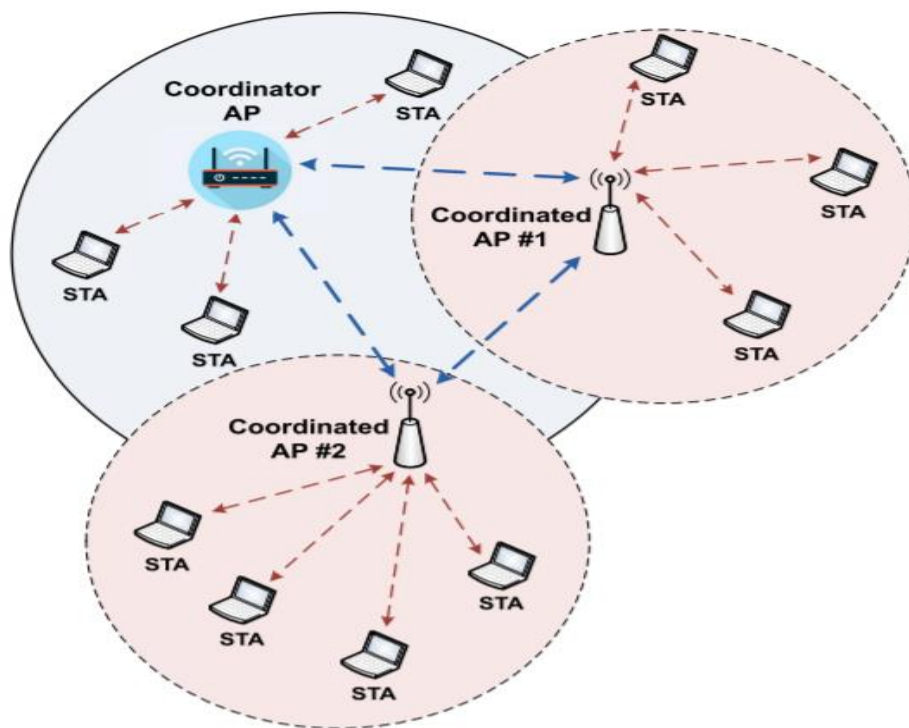

FIGURE 58 : MANAGED OBSS

The Figures 56/57/58 are enhancements to support TSN in Wi-Fi 7 that proposed from TGbe group.

## 5.5 USE CASES OF TIME-SENSITIVE NETWORKING IN WI FI 7

Providing bounded latency is highly critical both in traditional industrial and in new promising use cases.

As shown in Table 11, these can be classified into five major areas: Multimedia, health care, industrial, transport, and financial. [34]

Sector	Use case	Requirements		
		Latency (ms)	Reliability (%)	Throughput (Mbps)
Multimedia	High-quality video	3-10	>99.9	5 - 25
	Virtual reality (VR)	10-20	>99.9	25 - 500
	Augmented reality (AR)	1 - 50	>99.99	1 - 200
	Real-time pro gaming	5 - 50	>99.9	>3
	Cloud gaming	5 - 50	>99.9	10 - 35
Health Care	Telesurgery	1 - 10	>99.9999	~ 10
	Tele diagnosis, Telemonitoring, and Telerehabilitation	50 - 200	>99.9	0.5 - 5
	Exoskeletons and Prosthetic hands	5 - 20	>99.999	0.2 - 1
Industrial	Process automation	1 - 50	>99.99	0.1 - 5
	Human machine interface (HMI) m	50 - 200	>99.9	~ 1
	Tactile / Haptic technology	1 - 5	>99.999	~ 1
	Drone control	< 100	>99.99	1 - 10
Transport	Automated guided vehicle (AGV)	10 - 50	>99.9999	~ 1
	Remote-controlled vehicle with video	10 - 100	>99.99	~ 10
	Real-time traffic information	40 - 500	>99	0.1 - 1
Financial	High-frequency trading	0.1 - 1	>99.9999	0.1 - 1

TABLE 11 : USE CASES OF TSN

### 5.5.1 MULTIMEDIA

WIFI is today the dominant Internet access technology for mobile devices in home and office environments running multimedia applications. The short-term development of this field provides the consolidation of more advanced time-sensitive services as real-time high-quality 4K/8K audio and video streaming, virtual reality, augmented reality (AR), cloud gaming and interactive applications that will not be intended only for entertainment, but also for educational and training aims.

The already widespread adoption of WIFI technology indoors, its backward compatibility, and the distinguishing features compared with wired alternatives (flexibility , simplicity , essentially and mobility) they suggest that the appearance of a low-latency operation mode for WIFI 7 will be placed as a preferential option for upcoming multimedia use cases together with 5G enhanced Mobile Broadband.

#### Cloud Gaming

For the past decade, video games have been enriched with online features, from competitive and collaborative multiplayer features to downloadable content such as maps and player customization. Cloud gaming is the next step, with games being streamed entirely from a server, with no physical hardware required to play. The Google Stadia is at the forefront of this technology promises remote gaming quality 4K at 60 fps. Most current online games have noticeable lag of about 50 ms. However, scientific studies show that the brain can recognize images with only 13 ms , which is less than the time duration of a single frame at 60 fps (16.7 ms). Therefore, to provide the best user experience, for video game companies it will be increasingly important to maintain delay controlled while maximizing reliability. Most cloud gaming traffic consists of time-sensitive frames relaying player movement and actions to the server in the UL and the subsequent environment response in the DL. At the same time, other users in the same network may be connected to audio and/or video streaming services.

### 5.5.2 HEALTH CARE

The latest developments in IT such as artificial intelligence, Big Data, ultra-high video resolution will take health care to a next level, allowing a multitude of innovative applications treatment (telesurgery), remote diagnosis (tele diagnosis), and recovery (telemonitoring - telerehabilitation - exoskeletons - prosthetic hands) for a wide range of diseases. Wi-Fi 7 and 5G will once again play an important role as enablers of new medical wearables and devices intended for use in smart health care and home environments.

Regarding the specific use cases, some of them have common features with the field of multimedia (tele diagnosis, telemonitoring, and telerehabilitation). Because of their criticality, some others require additional network extremely strict requirements in terms of e reliability, latency, and security (e.g., telesurgery). And finally, a third group involving remote motion control with relatively low traffic load requires a fully deterministic approach (e.g., exoskeletons and prosthetic hands).

### 5.5.3 INDUSTRY 4.0

During the next years, wireless networks will have increasing weight in the industry, leading a trend towards more flexible production sites and consolidating the Industry 4.0 concept. Connected factories will then become a reality, involving monitoring, management, and direct control of machines, robots, and other industrial assets. Future industrial communications will probably rely on the coexistence among wired (e.g., Fieldbus-based and Industrial Ethernet), wireless (from RFID to LoRa, to cite two examples), and 5G/6G-based cellular technologies.

Wi-Fi 7 is also expected to get a foothold in this sector, not only because of its inherited features (namely, flexibility, ease of installation, scalability, and interoperability), but also thanks to its new enhancements, particularly in terms of improved resource management and support to deterministic communications.

#### 5.5.4 TRANSPORT

Transport is undergoing such profound changes that future mobility will certainly be documented by automation, sustainability, road/air/sea safety, and energy efficiency. Real-time traffic information is starting to show up regularly in drivers, using for example Wi-Fi implementations throughout the city. However, the coming revolution is driven by autonomous vehicles and automated guided vehicles, which will be able to transport people and goods thanks to their WIFI/5G connections without any human intervention. Next-generation vehicle communication and processing systems, such as vehicle-to-everything (V2E) communication or advanced driver-assistance systems, will help future transport systems based on the TSN and artificial intelligence.

Therefore, ensuring very high reliability and low latency in future transport applications will become critical regardless of the technology used, due to the high relative speeds between the end devices, and the continuous dynamism and low predictability of the external environment.

#### 5.5.5 INTERACTIVE MUSEUM

Museums around the world are based on a long time in technology to display information, provide content, and engage visitors in their exhibitions. Known examples are informative videos, audio guides, interactive games, hands-on experiments, and smartphone applications. In this respect, the latest advancements in augmented reality (AR) allow its adoption by interactive museums, thus giving editors the opportunity to place more information on top of existing exhibits.

To deal with the volume, distribution, and dynamic behavior of visitors in the various rooms (usually moving too far and wide and even create populated groups of people), the wireless network of the museum requires not only the deployment of a high number of APs, but also a coordinated operation under a multi-AP system.



## 6. PERFORMANCE RESULTS

### SCENARIO I

In the following scenario, the use case of an simulation is to evaluate the performance of a network in a residential scenario by using MATLAB to simulate the scenario. The parameters used in the simulation are detailed in Table 12. APS and Nodes are placed randomly. The Results section plots performance metrics such as throughput, latency, and packet loss, which will be explained below.

The residential scenario consists of a building with 2 floors. The spacing between the floors is 2 meters. Each floor consists of four rooms each having dimensions 12m x 12m x 2m. Each room has an access point (AP) and one station (STA) placed randomly at a height of 2 meters from the floor. Each AP has data for STA present in the same room. The simulation scenario specifies a path loss model based on the distance between the nodes, and the number of walls and floors traversed by the WLAN signal.

Deployment Parameters	Value
Floors	2
Room Size	12x12x2
Building Layout	2x2x2
Stations Per Room	1
Number of Nodes	16

PHY & MAC Parameters	Value
Operating frequency	6 GHz
STA sensitivity	-82dBm / -90dBm
Channel bandwidth	20 / 160 MHz
Tx Format	HE_SU
TX Power	15/20
Packet Size	1500/3000
Frequencies	5.9 GHz
Band	2.4 GHz and 6 GHz
Max Subframes	64/256

TABLE 12 : SIMULATION PARAMETERS

The simulation models the MAC and PHY layer of all the nodes (APs and STAs) using abstractions. The MAC layer implements enhanced distributed channel access (EDCA) functionality. The PHY layer like the MAC uses abstraction for WLAN signal generation and decoding.

Physical layer abstraction, or link-to-system mapping is a method to run simulations in a timely manner by accurately predicting the performance of a link in a computationally efficient way.

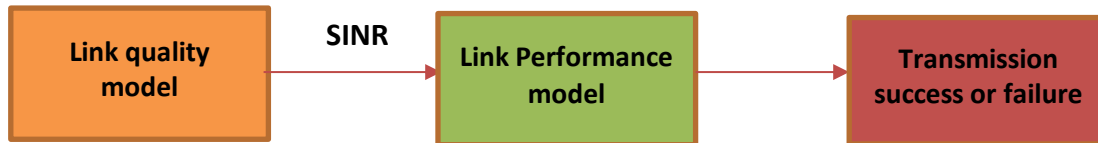

**The link quality** model calculates the post-equalizer signal to interference and noise ratio (SINR) per subcarrier. For a receiver, this is based on the location and transmission characteristics of the transmitter of interest, and interfering transmissions, and the impact of large- and small-scale fading.

**The link performance model** predicts the momentary packet error rate (PER), and accordingly transmission success of an individual packet, given the SINR per subcarrier and coding parameters is using for the transmission.

## 📌 CASE 1

In the first case we simulate a room size with 12x12x2 and with all nodes transmit 1500 bytes of packet, DataRate 600000Kbps. The frequency is 6GHz the band at 2.4GHz and the channel at 6GHz. All nodes have a bandwidth 20 and TxMCS 7.

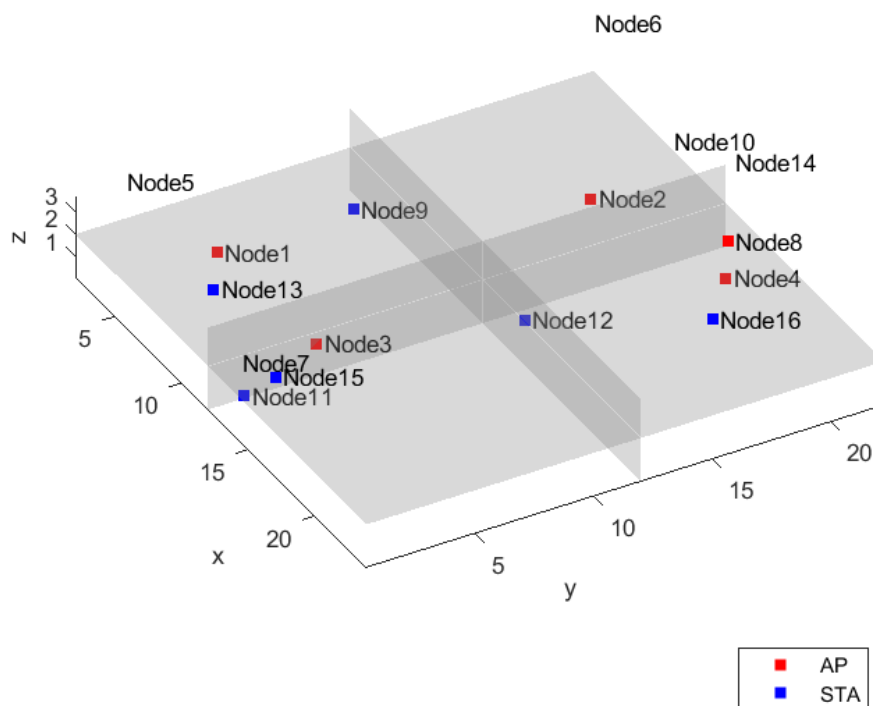

FIGURE 59 : ROOM SIZE PARAMETERS

Fields	SourceNode	DestinationNode	PacketSize	DataRateKbps	AccessCategory
1	1	9	1500	600000	0
2	2	10	1500	600000	0
3	3	11	1500	600000	0
4	4	12	1500	600000	0
5	5	13	1500	600000	0
6	6	14	1500	600000	0
7	7	15	1500	600000	0
8	8	16	1500	600000	0

FIGURE 60 : TRAFIC CONFIGS

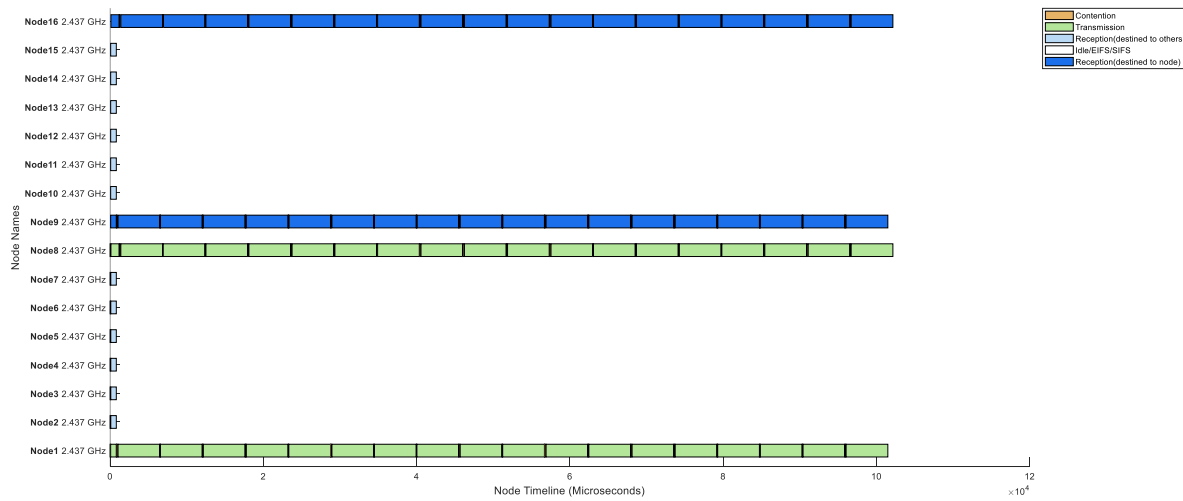
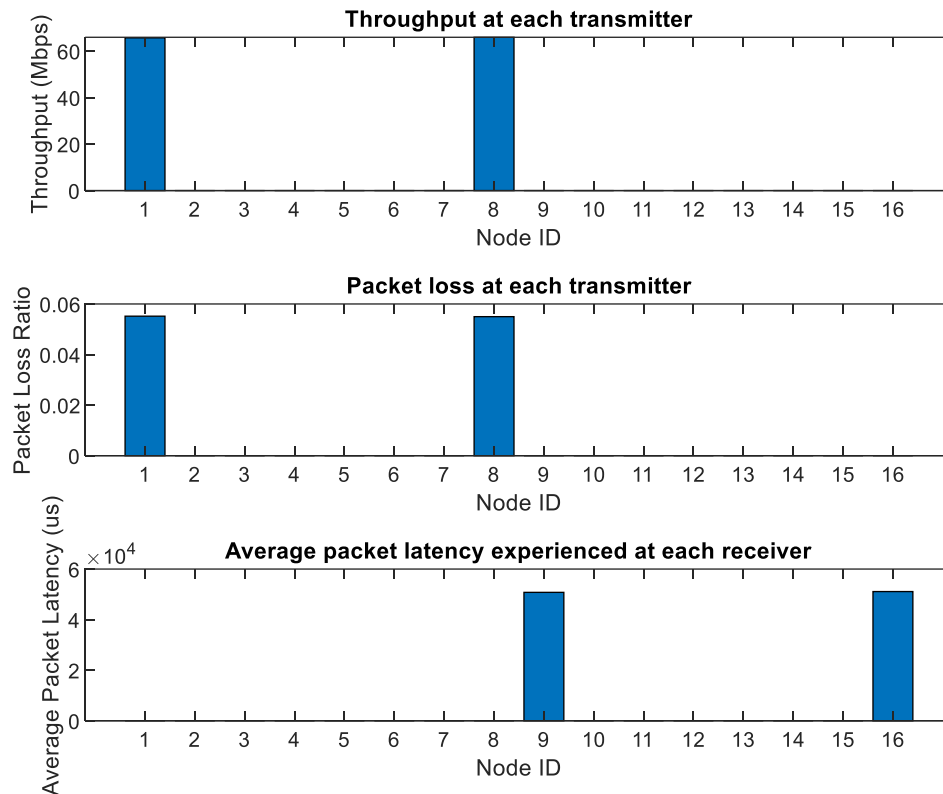

FIGURE 61 : MAC STATE OVER TIME



**FIGURE 62 : THROUGHPUT - PACKET LOSS - AVERAGE PACKET LATENCY**

The Figure 62 shows the MAC state as a function of time for every Node.

We can see the pathloss between nodes. Path loss is a function of the number of walls, floors, and the distance between nodes.

The Figure 63 presents the throughput // packet loss and the average packet latency of every node.

Also, the Figure 63 show us the throughput and packet loss ratio at each transmitter (APS) and the average packet latency at each receiver node (STAs).

The throughput shows us the achieved data rate at each AP in Megabits per second (Mbps).

The average packet latency shows the average latency at each STA to receive its downlink traffic from the AP.

We can see the path loss between each pair of nodes at the transmitter (APS) and receiver STAs.

statistics(1,1)						64	65	66
statistics(1,1)						EIFSStateTime	RxStateTime	Throughput
	1	2	3	4	5			
	ActiveOperationInFreq	AppTx	AppRx	AppRxBytes	AppAvgPacketLatency	1 Node1		
Node1	1	5000	0	0	0	2 Node2	0	0
Node2	1	5000	0	0	0	3 Node3	0	0
Node3	1	5000	0	0	0	4 Node4	0	0
Node4	1	5000	0	0	0	5 Node5	0	0
Node5	1	5000	0	0	0	6 Node6	0	0
Node6	1	5000	0	0	0	7 Node7	0	0
Node7	1	5000	0	0	0	8 Node8	0	65.9255
Node8	1	5000	0	0	0	9 Node9	0	9.4152e+04
Node9	1	0	548	822000	5.0784e+04	10 Node10	0	0
Node10	1	0	0	0	0	11 Node11	0	0
Node11	1	0	0	0	0	12 Node12	0	0
Node12	1	0	0	0	0	13 Node13	0	0
Node13	1	0	0	0	0	14 Node14	0	0
Node14	1	0	0	0	0	15 Node15	0	0
Node15	1	0	0	0	0	16 Node16	0	9.4488e+04
Node16	1	0	550	825000	5.1101e+04			

	86	87	88
	PhyTxBytes	PhyTxTime	PacketLossRatio
Node1	841728	9.3288e+04	0.0552
Node2	0	0	0
Node3	0	0	0
Node4	0	0	0
Node5	0	0	0
Node6	0	0	0
Node7	0	0	0
Node8	844800	9.3624e+04	0.0550
Node9	0	0	0
Node10	0	0	0
Node11	0	0	0
Node12	0	0	0
Node13	0	0	0
Node14	0	0	0
Node15	0	0	0
Node16	0	0	0

**CASE 2**

In this case the only change what we have accomplished is the TxMCS at only node[1] [transmitter] with value 11.

Fields	NodePosition	TxFormat	Bandwidth	TxMCS
1	[5.0043,4.7612,1.5...	"HE_SU"	20	11
2	[8.6439,18.4658,1....	"HE_SU"	20	7
3	[12.0014,5.0303,1....	"HE_SU"	20	7
4	[15.6280,20.2226,...	"HE_SU"	20	7
5	[1.7611,2.4534,3.5...	"HE_SU"	20	7
6	[1.1081,22.5374,3....	"HE_SU"	20	7
7	[14.2351,0.3287,3....	"HE_SU"	20	7
8	[16.1467,20.0456,...	"HE_SU"	20	7
9	[5.0077.10.5167.1....	"HE_SU"	20	7

**FIGURE 63 : NODE CONGIGS**

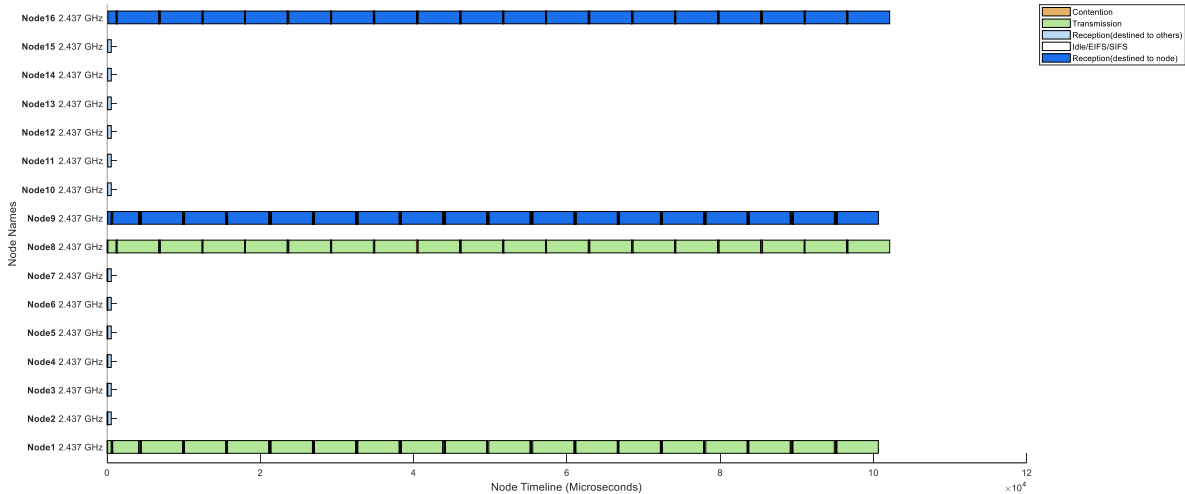

**FIGURE 64 : MAC STATE OVER TIME**

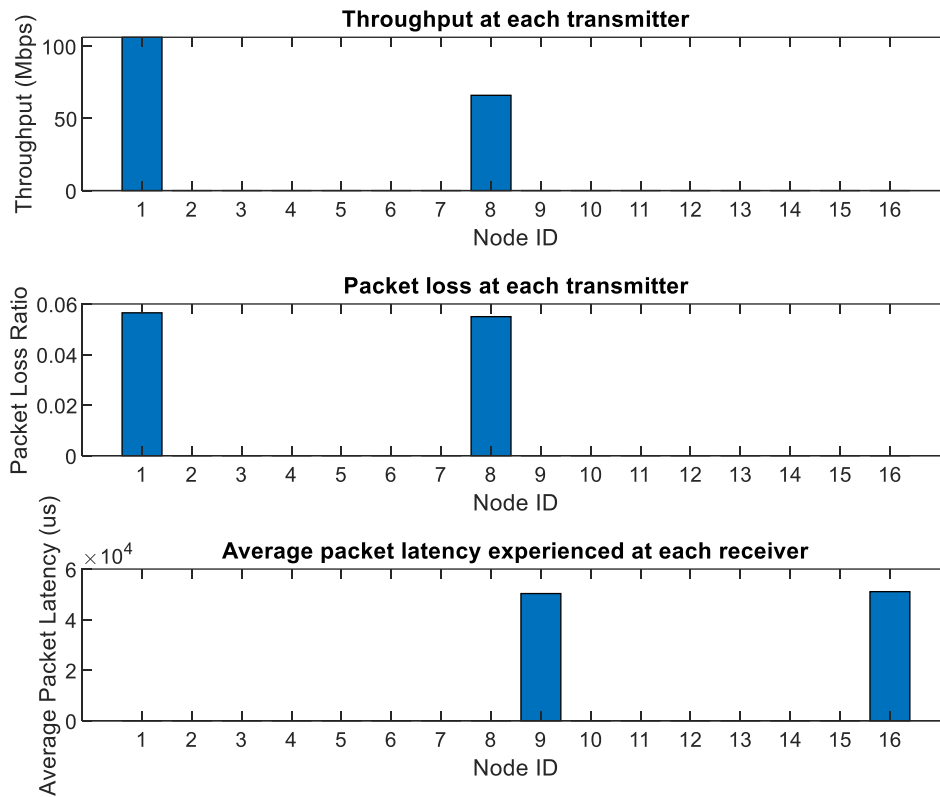
**FIGURE 65 : THROUGHPUT - PACKET LOSS - AVERAGE PACKET LATENCY**

From the two images above what we observe an increase of throughput in node[1] ,from 65Mbps to 100Mbps. The Packet Latency in node[9] has a little bit decrease.



**CASE 3**

In the third simulation we changed the TxMCs value of node[1] again to 7, but this time we increased the value of packet size of node[1] to 3000, with this increase we notice differences in all our nodes.

Fields	SourceNode	DestinationNode	PacketSize	DataRateKbps
1	1	9	3000	600000
2	2	10	1500	600000
3	3	11	1500	600000
4	4	12	1500	600000
5	5	13	1500	600000
6	6	14	1500	600000
7	7	15	1500	600000
8	8	16	1500	600000

FIGURE 66 : NODE CONGIGS

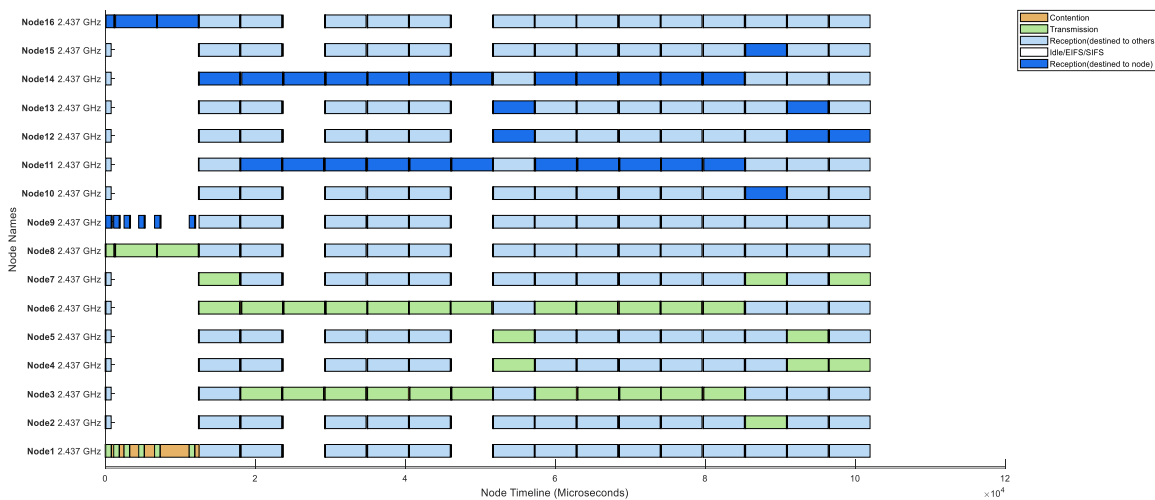

FIGURE 67 : MAC STATE OVER TIME

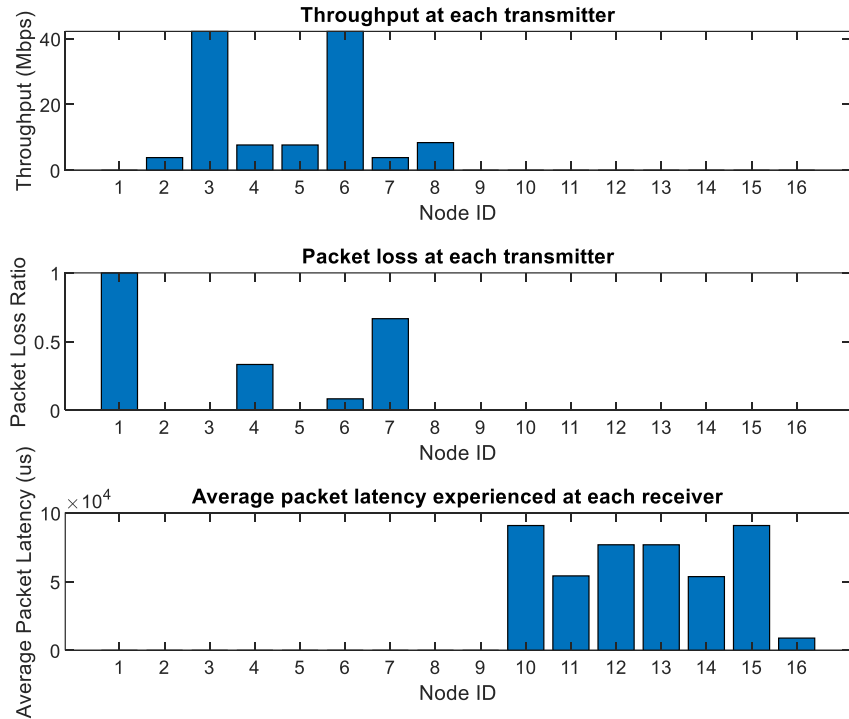

FIGURE 68 : THROUGHPUT - PACKET LOSS - AVERAGE PACKET LATENCY

With the increase in the number of packet the value of APTx was reduced by half.

	1 ActiveOperationInFreq	2 AppTx	3 AppRx	4 AppRxBytes
1 Node1	1	2501	0	0
2 Node2	1	5000	0	0
3 Node3	1	5000	0	0
4 Node4	1	5000	0	0
5 Node5	1	5000	0	0
6 Node6	1	5000	0	0
7 Node7	1	5000	0	0
8 Node8	1	5000	0	0
9 Node9	1	0	0	0
10 Node10	1	0	32	48000
11 Node11	1	0	352	528000
12 Node12	1	0	64	96000
13 Node13	1	0	64	96000
14 Node14	1	0	352	528000
15 Node15	1	0	32	48000
16 Node16	1	0	70	105000

We notice that in node[1] we have zero of bandwidth and the increase of packet loss to 1. This had as a consequence and zeroing of the packet latency in the repository node[9] that the link between them. We also notice the changes in the rest of nodes.

		64	65	66		86	87	88
		EIFSStateTime	RxStateTime	Throughput		PhyTxBytes	PhyTxTime	PacketLossRatio
1 Node1	70	370.0000	83182	0	1 Node1	36432	4344	1
2 Node2	48	330.0000	90092	3.8400	2 Node2	49152	5444	0
3 Node3	28	216.0000	34354	42.2400	3 Node3	540672	5.9884e+04	0
4 Node4	96	221.0000	84567	7.6800	4 Node4	98304	10888	0.3333
5 Node5	96	253.0000	84551	7.6800	5 Node5	98304	10888	0
5 Node6	00	156.0000	28894	42.2400	6 Node6	589824	6.5328e+04	0.0833
7 Node7	00	205.0000	84639	3.8400	7 Node7	98304	1.0888e+04	0.6667
3 Node8	00	572.0000	83182	8.4000	8 Node8	107520	11964	0
3 Node9	0	657.0000	87539	0	9 Node9	0	0	0
10 Node10	0	221.0000	95564	0	10 Node10	0	0	0
11 Node11	0	268.0000	94766	0	11 Node11	0	0	0
12 Node12	0	188.0000	9.5563e+04	0	12 Node12	0	0	0
13 Node13	0	253.0000	95562	0	13 Node13	0	0	0
14 Node14	0	96.0000	94780	0	14 Node14	0	0	0
15 Node15	0	221.0000	95575	0	15 Node15	0	0	0
16 Node16	0	572.0000	95290	0	16 Node16	0	0	0

 **CASE 4**

In the 4 case we turned the value of packet Size again to 1500 but in this simulation we increased the Datarate of Node[1] now to 900000kbps.

Fields	SourceNode	DestinationNode	PacketSize	DataRateKbps
1	1	9	1500	900000
2	2	10	1500	600000
3	3	11	1500	600000
4	4	12	1500	600000
5	5	13	1500	600000
6	6	14	1500	600000
7	7	15	1500	600000
8	8	16	1500	600000

FIGURE 69 : NODE CONGIGS

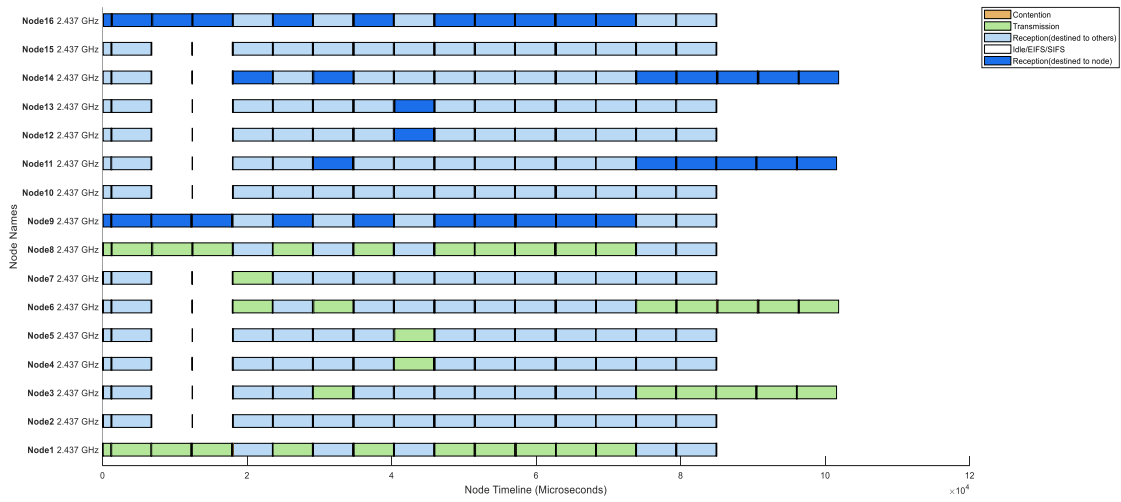

FIGURE 70 : MAC STATE OVER TIME

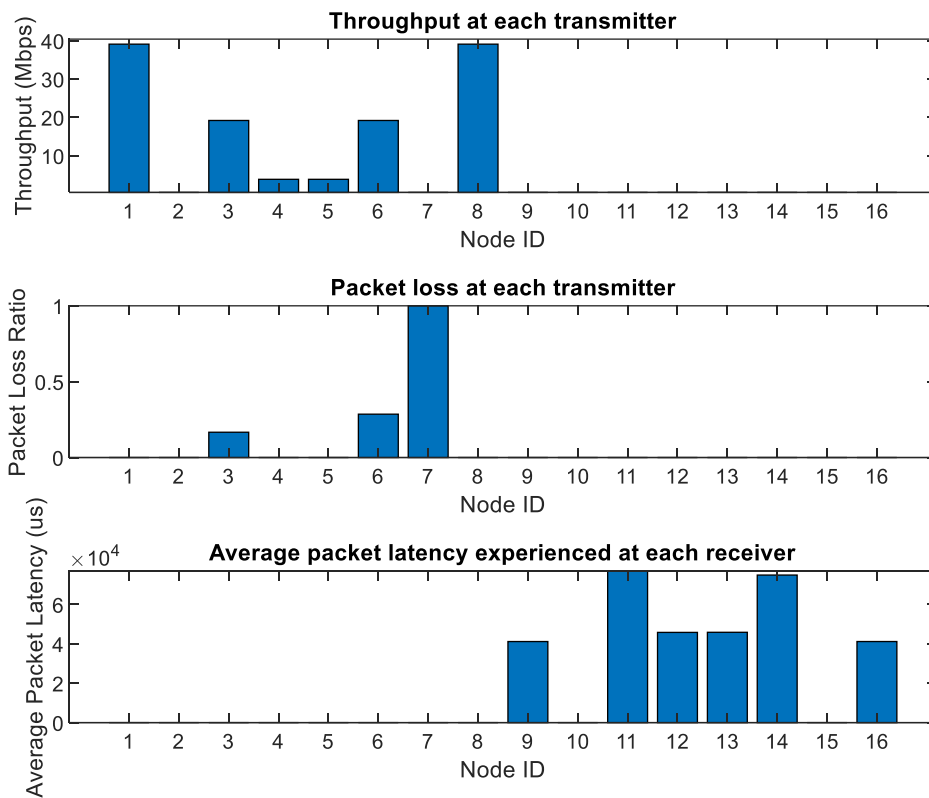

FIGURE 71 : THROUGHPUT - PACKET LOSS - AVERAGE PACKET LATENCY

With the increase in the value of Data-rate we observe that the value of APTX was increased , compared to the previous case where it decreased with the increase of Packets.

The throughput at node[1] has a little decrease to 40Mbps. The packet Loss in node[9] decrease to zero.

	Node1	Node2	Node3	Node4	Node5
1 ActiveOperationInFreq	1	1	1	1	1
2 AppTx	7500	5000	5000	5000	5000
3 AppRx	0	0	0	0	0
4 AppRxBytes	0	0	0	0	0
5 AppAvgPacketLatency	0	0	0	0	0
6 MACInternalCollisionsAC1	0	0	0	0	0
7 MACInternalCollisionsAC2	0	0	0	0	0
8 MACInternalCollisionsAC3	0	0	0	0	0
9 MACInternalCollisionsAC4	0	0	0	0	0

As a result, the difference in the throughput - Packet Loss of the node[1] between the two cases. Also we observe and the changes at packet latency with decrease of node[9] which is the receiver.

	1	2	3	4	5		51	52
	ActiveOperationInFreq	AppTx	AppRx	AppRxBytes	AppAvgPacketLatency		MACRxDrop	MACDataRx
1 Node1	1	7500	0	0	0	1 Node1	0	0
2 Node2	1	5000	0	0	0	2 Node2	280	0
3 Node3	1	5000	0	0	0	3 Node3	98	0
4 Node4	1	5000	0	0	0	4 Node4	129	0
5 Node5	1	5000	0	0	0	5 Node5	234	0
6 Node6	1	5000	0	0	0	6 Node6	180	0
7 Node7	1	5000	0	0	0	7 Node7	288	0
8 Node8	1	5000	0	0	0	8 Node8	96	0
9 Node9	1	0	326	489000	4.1169e+04	9 Node9	42	326
10 Node10	1	0	0	0	0	10 Node10	233	0
11 Node11	1	0	160	240000	7.7044e+04	11 Node11	100	160
12 Node12	1	0	32	48000	4.5810e+04	12 Node12	163	32
13 Node13	1	0	32	48000	4.5861e+04	13 Node13	265	32
14 Node14	1	0	160	240000	7.4925e+04	14 Node14	64	192
15 Node15	1	0	0	0	0	15 Node15	288	0
16 Node16	1	0	326	489000	4.1175e+04	16 Node16	96	326

	60 IdleStateTime		66 Throughput	67 MACAverageTimePerFrame	68 MACTxSuccess
1 Node1	0	1 Node1	39.1051	1.0221e+03	326
2 Node2	0	2 Node2	0	0	0
3 Node3	0	3 Node3	19.1927	2.3152e+03	160
4 Node4	0	4 Node4	3.8385	1.2614e+03	32
5 Node5	0	5 Node5	3.8385	1.2630e+03	32
6 Node6	0	6 Node6	19.1927	2.0689e+03	160
7 Node7	0	7 Node7	0	563.7500	0
8 Node8	0	8 Node8	39.1051	1.0025e+03	326
9 Node9	340.0000	9 Node9	0	0	0
10 Node10	103.0000	10 Node10	0	0	0
11 Node11	139.0000	11 Node11	0	0	0
12 Node12	70	12 Node12	0	0	0
13 Node13	70	13 Node13	0	0	0
14 Node14	295.0000	14 Node14	0	0	0
15 Node15	70	15 Node15	0	0	0
16 Node16	271.0000	16 Node16	0	0	0

	86 PhyTxBytes	87 PhyTxTime	88 PacketLossRatio
1 Node1	500736	5.5516e+04	0
2 Node2	0	0	0
3 Node3	245760	2.7220e+04	0.1667
4 Node4	49152	5.4440e+03	0
5 Node5	49152	5.4440e+03	0
6 Node6	294912	3.2664e+04	0.2857
7 Node7	49152	5.4440e+03	1
8 Node8	500736	5.5516e+04	0
9 Node9	0	0	0
10 Node10	0	0	0
11 Node11	0	0	0
12 Node12	0	0	0
13 Node13	0	0	0
14 Node14	0	0	0
15 Node15	0	0	0
16 Node16	0	0	0

**CASE 5**

In this case we keep the same parameters as the first case and the only different in the change of threshold in node[1] from -82dBm to -90dbm.

Node[1] = threshold -90dBm.

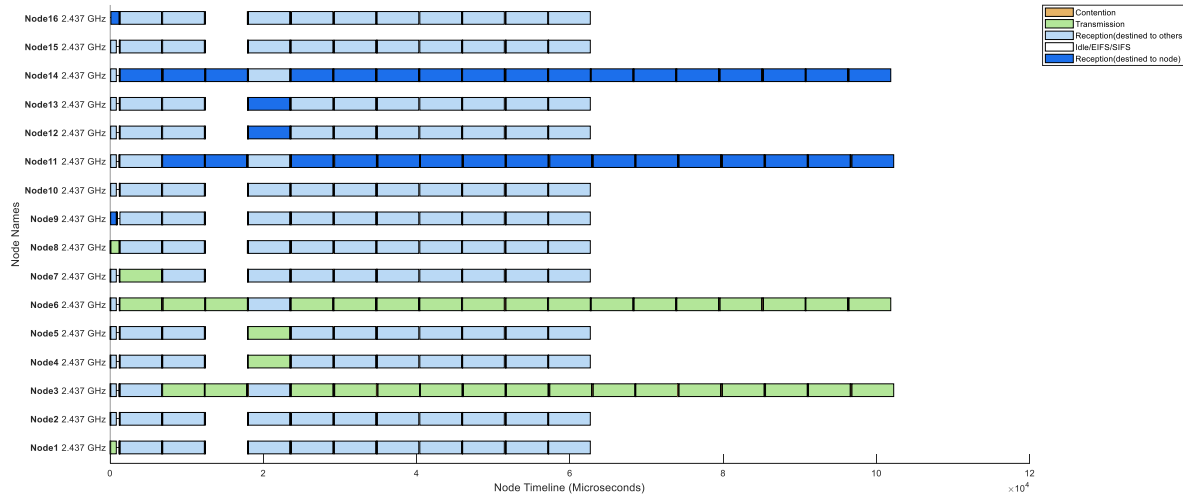

**FIGURE 72 :MAC STATE OVER TIME**

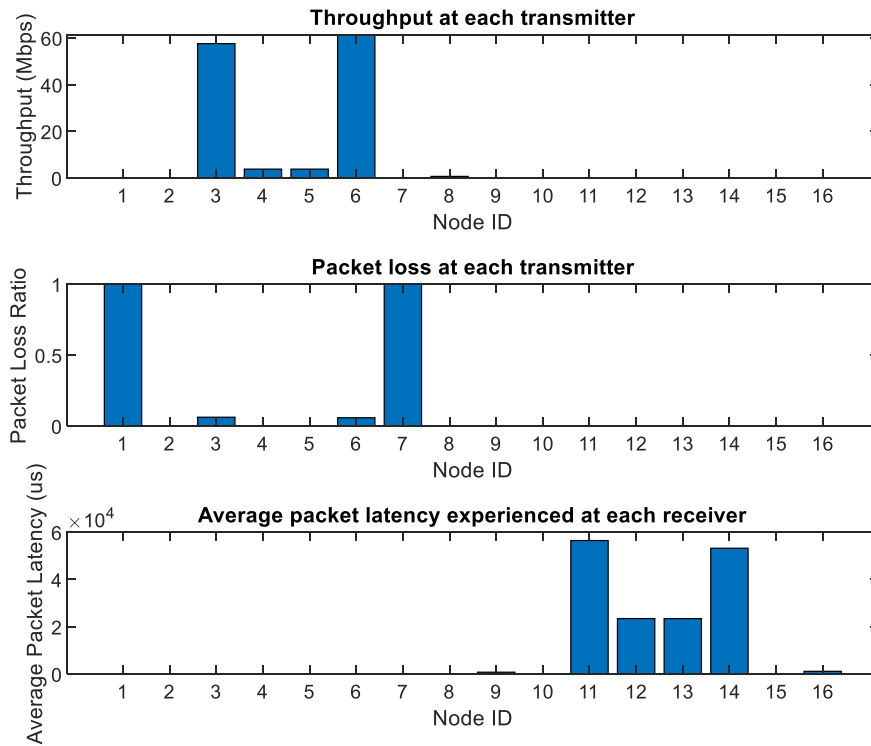

**FIGURE 73 :THROUGHPUT - PACKET LOSS - AVERAGE PACKET LATENCY**

With the increase of threshold of node[1] we observe that the throughput on nodes[1][2] is zero.

	64	65	66		2	3	4	5
	EIFSStateTime	RxStateTime	Throughput		AppTx	AppRx	AppRxBytes	AppAvgPacketLatency
1 Node1	296.0000	55413	0	1 Node1	5000	0	0	0
2 Node2	252.0000	56541	0	2 Node2	5000	0	0	0
3 Node3	67	12130	57.5988	3 Node3	5000	0	0	0
4 Node4	185.0000	51031	3.8399	4 Node4	5000	0	0	0
5 Node5	201.0000	51031	3.8399	5 Node5	5000	0	0	0
6 Node6	23	6638	61.4387	6 Node6	5000	0	0	0
7 Node7	185.0000	5.1056e+04	0	7 Node7	5000	0	0	0
8 Node8	348.0000	55381	0.7200	8 Node8	5000	0	0	0
9 Node9	236.0000	56169	0	9 Node9	0	4	6000	810
10 Node10	185.0000	56539	0	10 Node10	0	0	0	0
11 Node11	119	9.4510e+04	0	11 Node11	0	480	720000	5.6465e+04
12 Node12	185.0000	56523	0	12 Node12	0	32	48000	2.3475e+04
13 Node13	201.0000	56532	0	13 Node13	0	32	48000	2.3466e+04
14 Node14	23	9.4516e+04	0	14 Node14	0	512	768000	5.3219e+04
15 Node15	201.0000	56532	0	15 Node15	0	0	0	0
16 Node16	338.0000	56505	0	16 Node16	0	6	9000	1182

	60		88		51	52
	IdleStateTime		PacketLossRatio		MACRxDrop	MACDataRx
1 Node1	0	1 Node1	1	1 Node1	226	0
2 Node2	0	2 Node2	0	2 Node2	237	0
3 Node3	0	3 Node3	0.0625	3 Node3	0	0
4 Node4	0	4 Node4	0	4 Node4	224	0
5 Node5	0	5 Node5	0	5 Node5	261	0
6 Node6	0	6 Node6	0.0588	6 Node6	32	0
7 Node7	1	7 Node7	1	7 Node7	224	0
8 Node8	0	8 Node8	0	8 Node8	292	0
9 Node9	415	9 Node9	0	9 Node9	198	4
10 Node10	97	10 Node10	0	10 Node10	261	0
11 Node11	907	11 Node11	0	11 Node11	1	480
12 Node12	97	12 Node12	0	12 Node12	192	32
13 Node13	97	13 Node13	0	13 Node13	228	32
14 Node14	577.0000	14 Node14	0	14 Node14	0	512
15 Node15	97	15 Node15	0	15 Node15	224	0
16 Node16	106	16 Node16	0	16 Node16	291	6

We notice in node[1] we have increase of Packet Loss Ratio to 1, the average Packet Latency in node[9] which is the receiver of node[1] has a value close to zero.



**CASE 6**

In this case we keep the same parameters as the first case and we increase the TxPower to 20dBm from 15dBm.

With this increase we observe increase in MAC and PHY TxBytes.

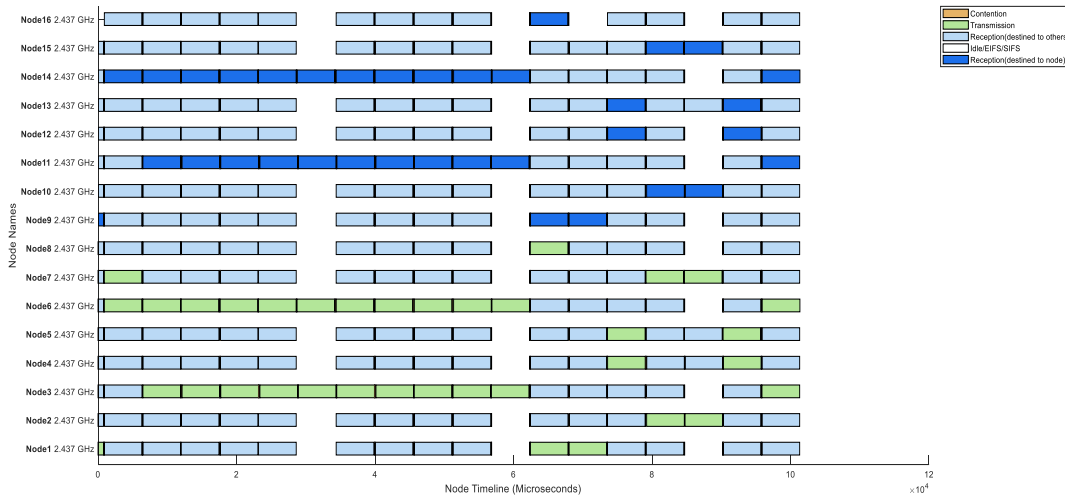

**FIGURE 74 : MAC STATE OVER TIME**

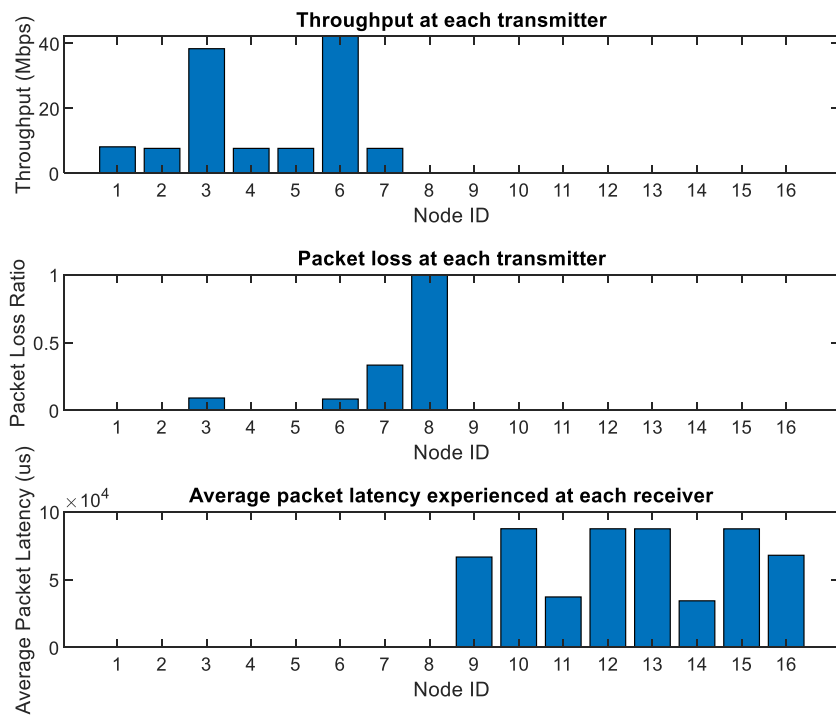

**FIGURE 75 : THROUGHPUT - PACKET LOSS - AVERAGE PACKET LATENCY**

	2	3	4	5		64	65	66
	AppTx	AppRx	AppRxBytes	AppAvgPacketLatency		EIFSStateTime	RxStateTime	Throughput
1 Node1	5000	0	0	0	1 Node1	189.0000	83140	8.1493
2 Node2	5000	0	0	0	2 Node2	301.0000	83848	7.6699
3 Node3	5000	0	0	0	3 Node3	175	3.9403e+04	38.3497
4 Node4	5000	0	0	0	4 Node4	293.0000	83786	7.6699
5 Node5	5000	0	0	0	5 Node5	293.0000	83855	7.6699
6 Node6	5000	0	0	0	6 Node6	131	3.3879e+04	42.1846
7 Node7	5000	0	0	0	7 Node7	217.0000	78351	7.6699
8 Node8	5000	0	0	0	8 Node8	520.0000	89317	0
9 Node9	0	68	102000	6.6571e+04	9 Node9	249.0000	94912	0
10 Node10	0	64	96000	87441	10 Node10	218.0000	94786	0
11 Node11	0	320	480000	37143	11 Node11	159	94323	0
12 Node12	0	64	96000	87399	12 Node12	226.0000	94884	0
13 Node13	0	64	96000	8.7365e+04	13 Node13	293.0000	94880	0
14 Node14	0	352	528000	3.4286e+04	14 Node14	71	94307	0
15 Node15	0	64	96000	8.7359e+04	15 Node15	233.0000	94823	0
16 Node16	0	32	48000	67869	16 Node16	400.0000	88625	0

statistics(1, 1)					51	52		59	60
	86	87	88		MACRxDrop	MACDataRx		MACOthersFramesInWaitForRe	IdleStateTime
	PhyTxBytes	PhyTxTime	PacketLossRatio						
1 Node1	104448	1.1628e+04	0	1 Node1	256	0	1 Node1	0	0
2 Node2	98304	10888	0	2 Node2	264	0	2 Node2	0	0
3 Node3	491520	5.4440e+04	0.0909	3 Node3	64	0	3 Node3	0	0
4 Node4	98304	10888	0	4 Node4	258	0	4 Node4	0	0
5 Node5	98304	10888	0	5 Node5	226	0	5 Node5	0	0
6 Node6	540672	5.9884e+04	0.0833	6 Node6	164	0	6 Node6	0	0
7 Node7	147456	16332	0.3333	7 Node7	256	0	7 Node7	1	0
8 Node8	49152	5.4440e+03	1	8 Node8	359	0	8 Node8	0	0
9 Node9	0	0	0	9 Node9	228	68	9 Node9	0	106
10 Node10	0	0	0	10 Node10	224	64	10 Node10	0	139
11 Node11	0	0	0	11 Node11	32	320	11 Node11	0	412
12 Node12	0	0	0	12 Node12	192	64	12 Node12	0	88
13 Node13	0	0	0	13 Node13	225	64	13 Node13	0	70
14 Node14	0	0	0	14 Node14	100	352	14 Node14	0	484.0000
15 Node15	0	0	0	15 Node15	262	64	15 Node15	0	91
16 Node16	0	0	0	16 Node16	291	32	16 Node16	0	6490

With this increase we observe decrease in throughput at node[1]. Also we observe that the packet loss at node[1] was reset to zero. The Packet latency at the node[9] the receiver has a decrease.

**CASE 7**

In this case we keep the same parameters as the first case and we increase the MaxSubFrames from 64 to 256.

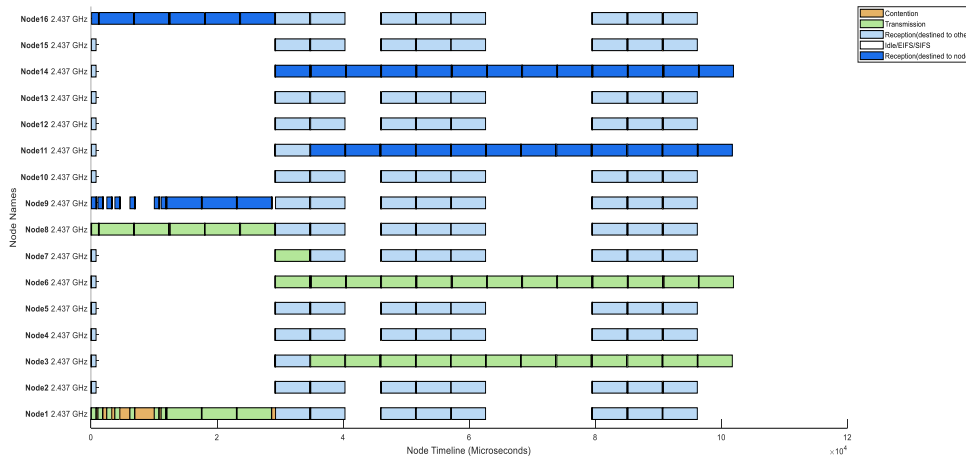

**FIGURE 76 : MAC STATE OVER TIME**

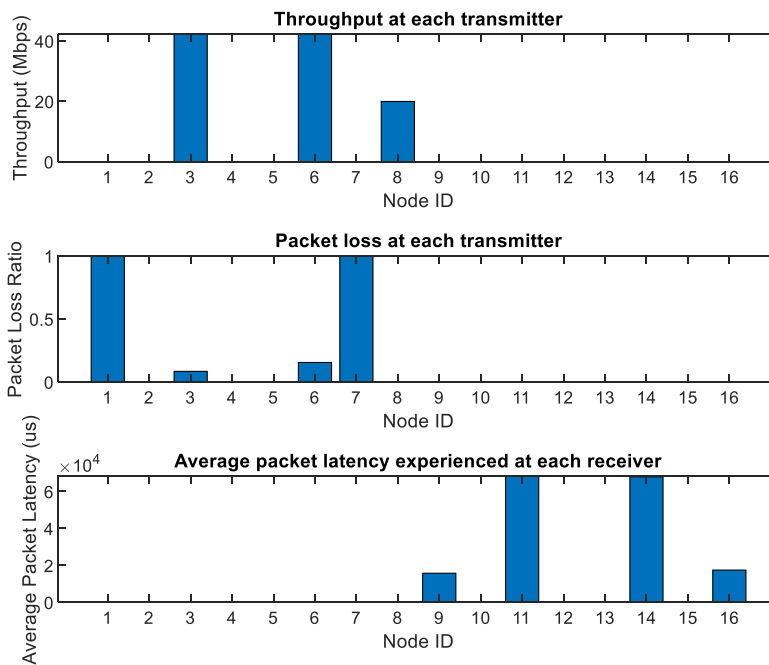

**FIGURE 77 : THROUGHPUT - PACKET LOSS - AVERAGE PACKET LATENCY**

	2	3	4	5		66
	AppTx	AppRx	AppRxBytes	AppAvgPacketLatency		Throughput
1 Node1	5000	0	0	0	1 Node1	0
2 Node2	5000	0	0	0	2 Node2	0
3 Node3	5000	0	0	0	3 Node3	42.2214
4 Node4	5000	0	0	0	4 Node4	0
5 Node5	5000	0	0	0	5 Node5	0
6 Node6	5000	0	0	0	6 Node6	42.2214
7 Node7	5000	0	0	0	7 Node7	0
8 Node8	5000	0	0	0	8 Node8	19.9112
9 Node9	0	36	54000	1.5658e+04	9 Node9	0
10 Node10	0	0	0	0	10 Node10	0
11 Node11	0	352	528000	6.8207e+04	11 Node11	0
12 Node12	0	0	0	0	12 Node12	0
13 Node13	0	0	0	0	13 Node13	0
14 Node14	0	352	528000	6.7823e+04	14 Node14	0
15 Node15	0	0	0	0	15 Node15	0
16 Node16	0	166	249000	1.7367e+04	16 Node16	0

statistics(1, 1)				51	52	
statistics(1, 1)				MACRxDrop	MACDataRx	
	86	87	88			
	PhyTxBytes	PhyTxTime	PacketLossRatio			
1 Node1	190464	2.1512e+04		1 Node1	4	0
2 Node2	0	0		2 Node2	240	0
3 Node3	540672	5.9884e+04	0.0833	3 Node3	0	0
4 Node4	0	0		4 Node4	224	0
5 Node5	0	0		5 Node5	228	0
6 Node6	589824	65328	0.1538	6 Node6	1	0
7 Node7	49152	5.4440e+03		7 Node7	224	0
8 Node8	254976	2.8296e+04		8 Node8	256	0
9 Node9	0	0		9 Node9	26	124
10 Node10	0	0		10 Node10	228	0
11 Node11	0	0		11 Node11	1	352
12 Node12	0	0		12 Node12	0	0
13 Node13	0	0		13 Node13	228	0
14 Node14	0	0		14 Node14	0	384
15 Node15	0	0		15 Node15	224	0
16 Node16	0	0		16 Node16	224	166

	59	60
	framesInWaitForRe	IdleStateTime
1 Node1	0	0
2 Node2	0	0
3 Node3	0	0
4 Node4	0	0
5 Node5	0	0
6 Node6	0	0
7 Node7	0	0
8 Node8	0	0
9 Node9	0	6526
10 Node10	0	70
11 Node11	0	340
12 Node12	0	70
13 Node13	0	70
14 Node14	0	492.0000
15 Node15	0	70
16 Node16	0	277

We can observe that with the increase of MaxSubFrames at node(1) we have sharp increase in packet Loss at node(1). The throughput of node[1] decrease to zero.

In Mac at node (1) we can see when we have in time contention Window.

**CASE 8**

In this case we change the Bandwidth of all nodes from 20 to 160.

All the others parameters are the same with first case.

Fields	NodePosition	TxFormat	Bandwidth	TxMCS
1	[5.0043,4.7612,1...	"HE_SU"	160	7
2	[8.6439,18.4658,...	"HE_SU"	160	7
3	[12.0014,5.0303,...	"HE_SU"	160	7
4	[15.6280,20.222...	"HE_SU"	160	7
5	[1.7611,2.4534,3...	"HE_SU"	160	7
6	[1.1081,22.5374,...	"HE_SU"	160	7
7	[14.2351,0.3287,...	"HE_SU"	160	7
8	[16.1467,20.045...	"HE_SU"	160	7
9	[5.0077,10.5167,...	"HE_SU"	160	7
10	[6.7043,22.7353,...	"HE_SU"	160	7
11	[13.6846,1.0205,...	"HE_SU"	160	7
12	[14.3772,12.468...	"HE_SU"	160	7
13	[9.6089,2.0380,3...	"HE_SU"	160	7
14	[11.6191,22.537...	"HE_SU"	160	7
15	[15.7611,1.1802,...	"HE_SU"	160	7
16	[20.3079,17.053...	"HE_SU"	160	7

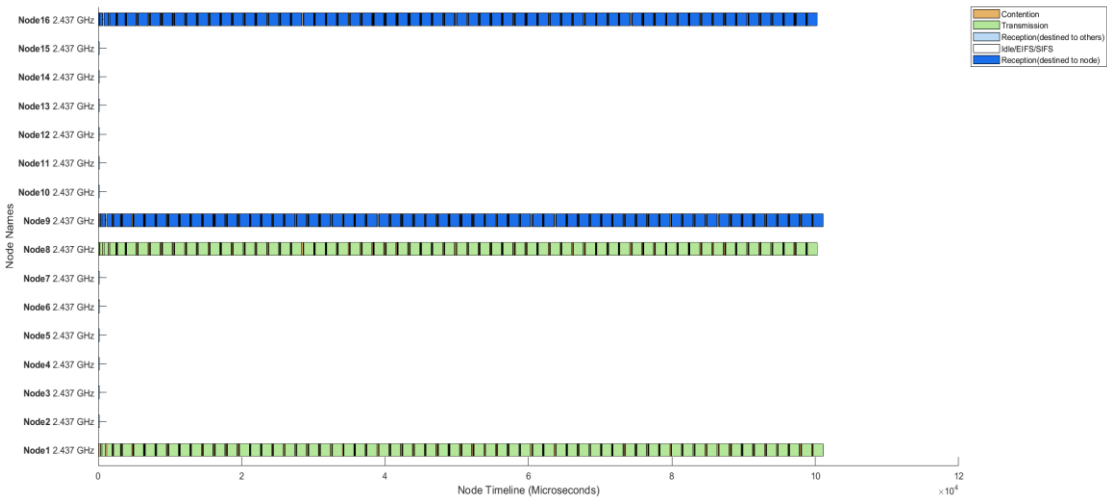

FIGURE 78 : MAC STATE OVER TIME

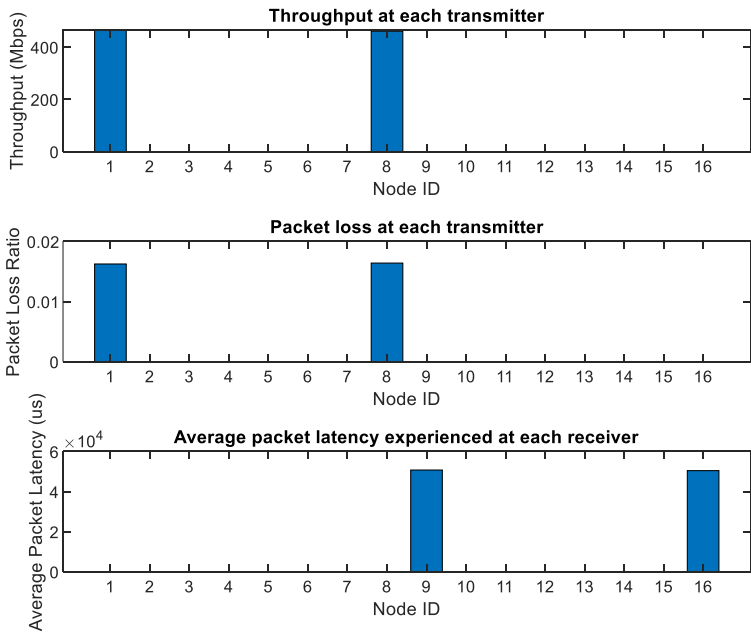

FIGURE 79 : THROUGHPUT - PACKET LOSS - AVERAGE PACKET LATENCY

		66					
		Throughput	1	2	3	4	5
			ActiveOperationInFreq	AppTx	AppRx	AppRxBytes	AppAvgPacketLatency
1 Node1	0	465.0562	1	5000	0	0	0
2 Node2	0	0	1	5000	0	0	0
3 Node3	0	0	1	5000	0	0	0
4 Node4	0	0	1	5000	0	0	0
5 Node5	0	0	1	5000	0	0	0
6 Node6	0	0	1	5000	0	0	0
7 Node7	0	0	1	5000	0	0	0
8 Node8	0	460.7368	1	5000	0	0	0
9 Node9	+04	0	1	0	3876	5814000	5.0734e+04
10 Node10	0	0	1	0	0	0	0
11 Node11	0	0	1	0	0	0	0
12 Node12	0	0	1	0	0	0	0
13 Node13	0	0	1	0	0	0	0
14 Node14	0	0	1	0	0	0	0
15 Node15	0	0	1	0	0	0	0
16 Node16	+04	0	1	0	3840	5760000	5.0438e+04

		51	52				60	
		MACRxDrop	MACDataRx	86	87	88	IdleStateTime	
				PhyTxBytes	PhyTxTime	PacketLossRatio		
1 Node1	0	0	0	11913216	8.4928e+04	0.0162	1 Node1	0
2 Node2	3	0	0	0	0	0	2 Node2	0
3 Node3	3	0	0	0	0	0	3 Node3	0
4 Node4	2	0	0	0	0	0	4 Node4	0
5 Node5	3	0	0	0	0	0	5 Node5	0
6 Node6	2	0	0	0	0	0	6 Node6	0
7 Node7	3	0	0	0	0	0	7 Node7	0
8 Node8	0	0	0	11770368	8.4156e+04	0.0164	8 Node8	0
9 Node9	0	3876	0	0	0	0	9 Node9	2.5450e+03
10 Node10	3	0	0	0	0	0	10 Node10	43
11 Node11	3	0	0	0	0	0	11 Node11	43
12 Node12	3	0	0	0	0	0	12 Node12	43
13 Node13	3	0	0	0	0	0	13 Node13	43
14 Node14	0	0	0	0	0	0	14 Node14	43
15 Node15	3	0	0	0	0	0	15 Node15	43
16 Node16	0	3840	0	0	0	0	16 Node16	2.5540e+03

In this simulation unlike the first case we have all the nodes with value bandwidth 160. We can observe big raise in throughput at nodes[1][8] compared to 1 case. The throughput increased close to 465Mbps in both nodes. Also, in these two nodes we have decrease in packet loss.

We observe the difference in Mac State Transmission over Time, in time we have a contention.

**CASE 9**

In this simulation we keep the Bandwidth of all nodes to 160 like seventh case and we change the band of node[1] to 6GHz.

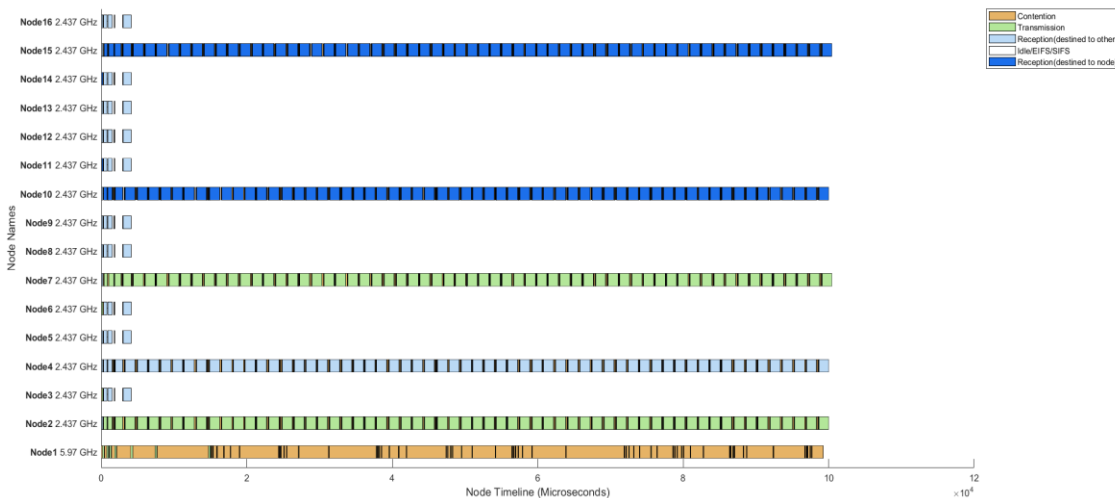

**FIGURE 80 : MAC STATE OVER TIME**

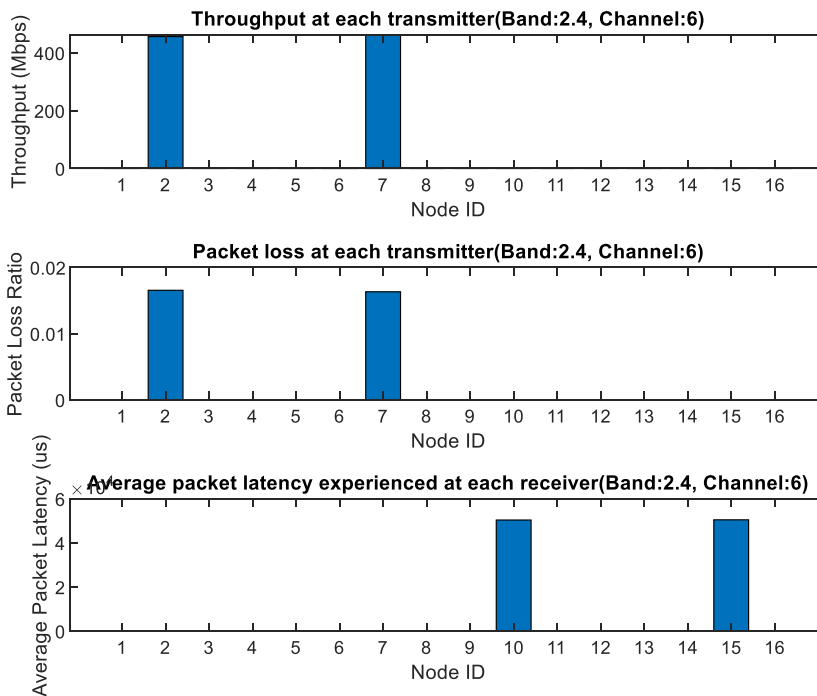

**FIGURE 81 :THROUGHPUT - PACKET LOSS - AVERAGE PACKET LATENCY (BAND 2.4)**



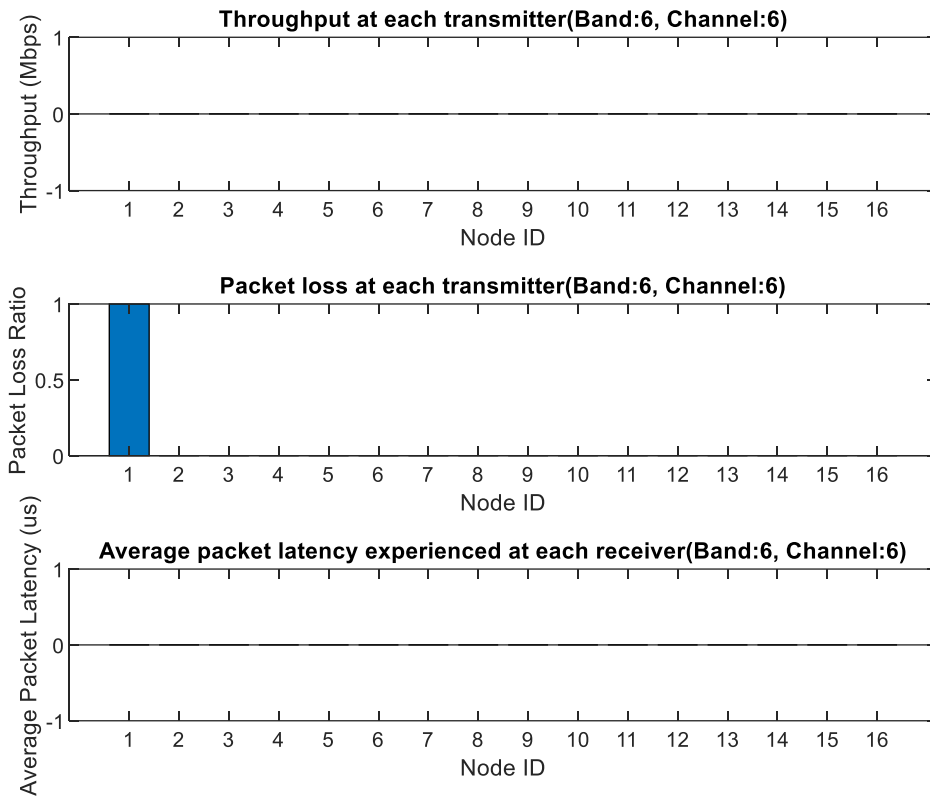

FIGURE 82 :THROUGHPUT - PACKET LOSS - AVERAGE PACKET LATENCY (BAND 6GHZ)

	2	3		85	86	87	88
	AppTx	AppRx		NumBasicNavUpdates	PhyTxBytes	PhyTxTime	PacketLossRatio
1 Node1	5000	0	1 Node1	0	6093312	4.8800e+03	1
2 Node2	0	0	2 Node2	0	0	0	0
3 Node3	0	0	3 Node3	0	0	0	0
4 Node4	0	0	4 Node4	0	0	0	0
5 Node5	0	0	5 Node5	0	0	0	0
6 Node6	0	0	6 Node6	0	0	0	0
7 Node7	0	0	7 Node7	0	0	0	0
8 Node8	0	0	8 Node8	0	0	0	0
9 Node9	0	0	9 Node9	0	0	0	0
10 Node10	0	0	10 Node10	0	0	0	0
11 Node11	0	0	11 Node11	0	0	0	0
12 Node12	0	0	12 Node12	0	0	0	0
13 Node13	0	0	13 Node13	0	0	0	0
14 Node14	0	0	14 Node14	0	0	0	0
15 Node15	0	0	15 Node15	0	0	0	0
16 Node16	0	0	16 Node16	0	0	0	0

As we changed to 6GHz band in node[1] we notice zeroing in throughput. The only that we can observe from figures is the packer loss ratio has a value 1. This happen because receiver and transmitter must be in the same band.

**CASE 10**

In this case we change all nodes to 6GHz and we kept the value of Bandwidth of 160 at all nodes.

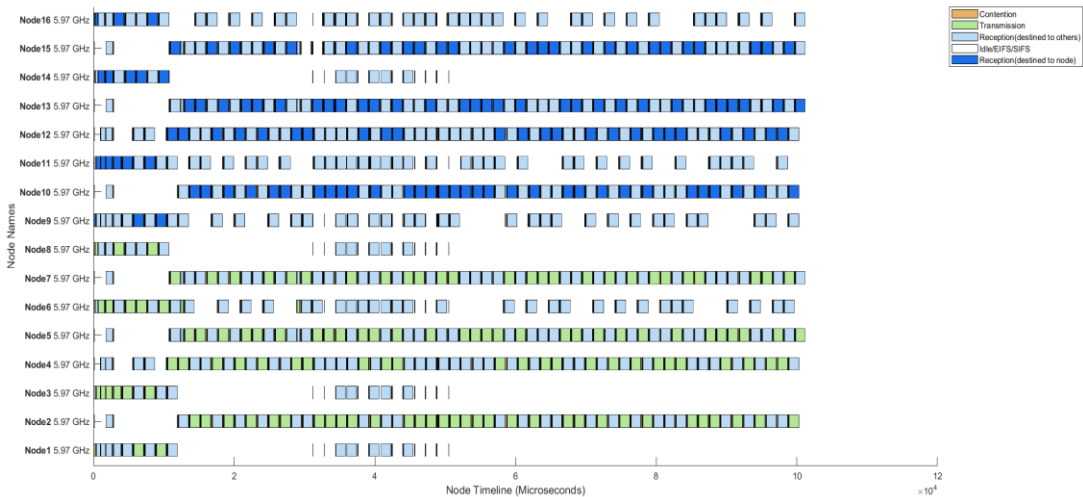

**FIGURE 83 : MAC STATE OVER TIME**

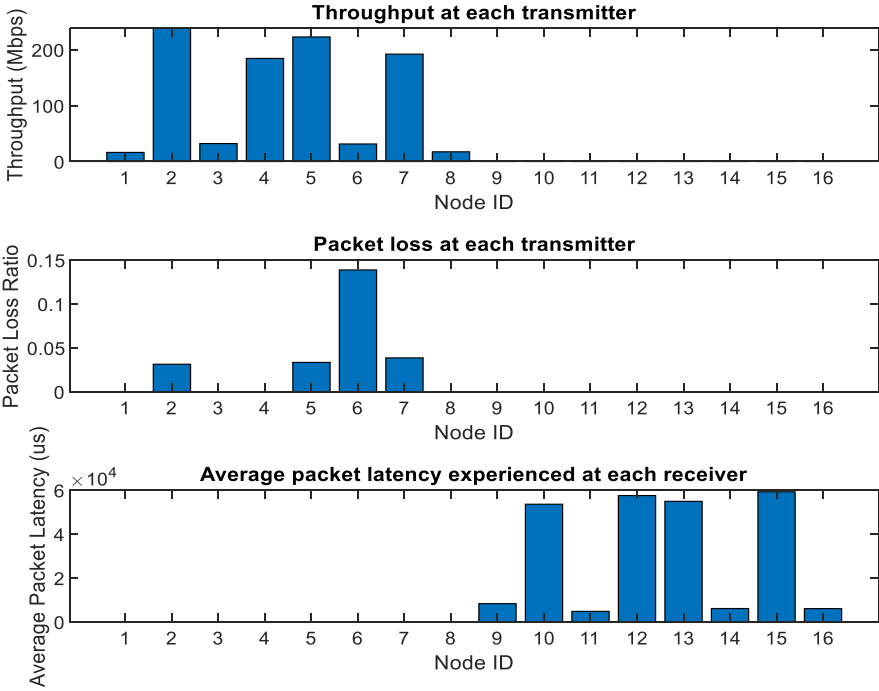

**FIGURE 84 : THROUGHPUT - PACKET LOSS - AVERAGE PACKET LATENCY**

	2	3	4	5		51		60
	AppTx	AppRx	AppRxBytes	AppAvgPacketLatency		MACRxDrop		IdleStateTime
1 Node1	5000	0	0	0	1 Node1	260	1 Node1	0
2 Node2	5000	0	0	0	2 Node2	83	2 Node2	0
3 Node3	5000	0	0	0	3 Node3	322	3 Node3	0
4 Node4	5000	0	0	0	4 Node4	199	4 Node4	0
5 Node5	5000	0	0	0	5 Node5	174	5 Node5	0
6 Node6	5000	0	0	0	6 Node6	200	6 Node6	0
7 Node7	5000	0	0	0	7 Node7	188	7 Node7	0
8 Node8	5000	0	0	0	8 Node8	535	8 Node8	0
9 Node9	0	135	202500	8.2816e+03	9 Node9	1244	9 Node9	367.0000
10 Node10	0	1984	2976000	5.3576e+04	10 Node10	391	10 Node10	691.0000
11 Node11	0	267	400500	4.7715e+03	11 Node11	2244	11 Node11	460.0000
12 Node12	0	1536	2304000	5.7501e+04	12 Node12	1118	12 Node12	682.0000
13 Node13	0	1856	2784000	5.4890e+04	13 Node13	77	13 Node13	535.0000
14 Node14	0	261	391500	6.0677e+03	14 Node14	208	14 Node14	97.0000
15 Node15	0	1600	2400000	5.9238e+04	15 Node15	1823	15 Node15	571.0000
16 Node16	0	144	216000	6.0498e+03	16 Node16	2261	16 Node16	478.0000

	66		87	88
	Throughput		PhyTxTime	PacketLossRatio
1 Node1	16.1999	1 Node1	2.9960e+03	0
2 Node2	238.0792	2 Node2	4.3452e+04	0.0313
3 Node3	32.0399	3 Node3	5.8760e+03	0
4 Node4	184.3194	4 Node4	3.3652e+04	0
5 Node5	222.7193	5 Node5	4.0652e+04	0.0333
6 Node6	31.3199	6 Node6	6.7160e+03	0.1386
7 Node7	191.9994	7 Node7	3.6400e+04	0.0385
8 Node8	17.2799	8 Node8	3.2400e+03	0
9 Node9	0	9 Node9	0	0
10 Node10	0	10 Node10	0	0
11 Node11	0	11 Node11	0	0
12 Node12	0	12 Node12	0	0
13 Node13	0	13 Node13	0	0
14 Node14	0	14 Node14	0	0
15 Node15	0	15 Node15	0	0
16 Node16	0	16 Node16	0	0

In this case, compared to case 7, we observe how the MAC-State is formed of the nodes as a function of time and the changes at throughput – Packet loss Ratio – Average Packet Latency.

**CASE 11**

In this case we kept the data of the previous measurement and changed the TXMCS in all nodes with value 11.

Below we can see the results.

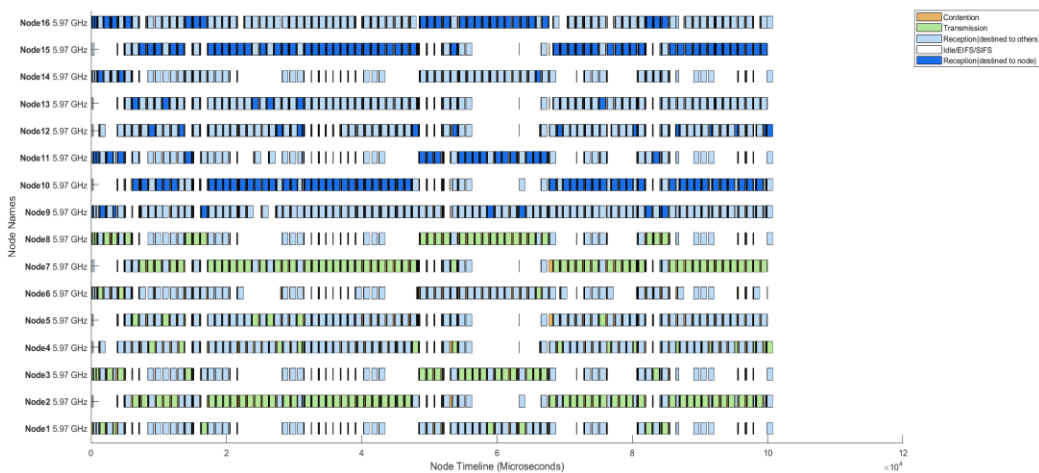

**FIGURE 85 : MAC STATE OVER TIME WITH(TXMCS 11)**

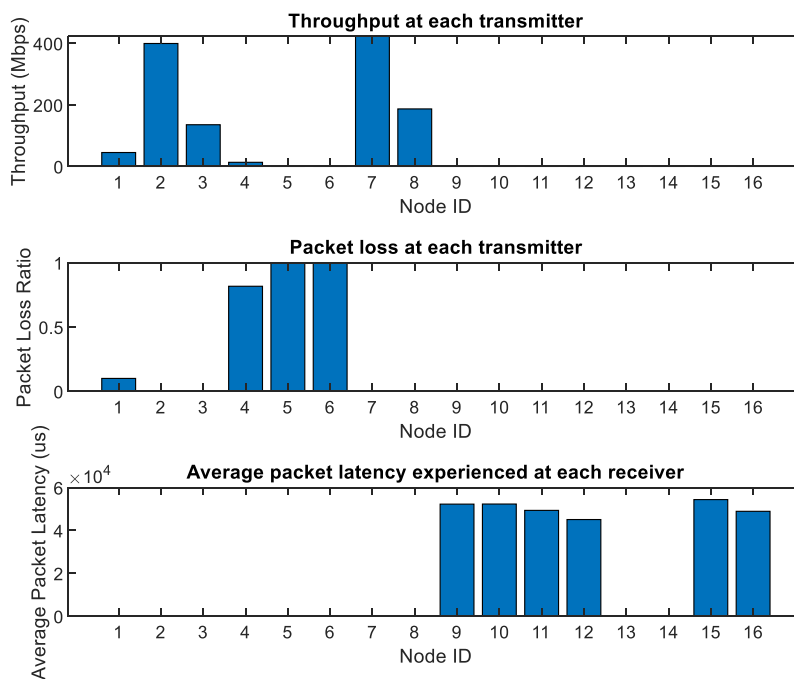

**FIGURE 86 :THROUGHPUT - PACKET LOSS - AVERAGE PACKET LATENCY (TXMCS 11)**

	2	3	4	5		49	50	51
	AppTx	AppRx	AppRxBytes	AppAvgPacketLatency		MACHESURx	MACHEEXTSURx	MACRxDrop
1 Node1	5000	0	0	0	01 Node1	37	0	2184
2 Node2	5000	0	0	0	02 Node2	27	0	879
3 Node3	5000	0	0	0	03 Node3	36	0	1801
4 Node4	5000	0	0	0	04 Node4	65	0	3915
5 Node5	5000	0	0	0	05 Node5	65	0	3920
6 Node6	5000	0	0	0	06 Node6	57	0	3477
7 Node7	5000	0	0	0	07 Node7	18	0	860
8 Node8	5000	0	0	0	08 Node8	28	0	1654
9 Node9	0	377	565500	5.2249e+04	09 Node9	96	0	4739
10 Node10	0	3328	4992000	5.2290e+04	10 Node10	80	0	945
11 Node11	0	1129	1693500	4.9332e+04	11 Node11	60	0	2106
12 Node12	0	112	168000	4.5062e+04	12 Node12	75	0	3917
13 Node13	0	0	0	0	13 Node13	72	0	855
14 Node14	0	0	0	0	14 Node14	48	0	2749
15 Node15	0	3520	5280000	5.4363e+04	15 Node15	73	0	862
16 Node16	0	1557	2335500	4.8898e+04	16 Node16	86	0	3626

	60		65	66		85	86	87	88
	IdleStateTime		RxStateTime	Throughput		MACNumBasicNavUpdates	PhyTxBytes	PhyTxTime	PacketLossRatio
1 Node1	0	1 Node1	8.8340e+04	45.2373	1 Node1	54	1219584	6.1560e+03	0.1002
2 Node2	0	2 Node2	3.6071e+04	399.3360	2 Node2	27	10518528	4.6332e+04	0
3 Node3	0	3 Node3	7.7911e+04	135.4719	3 Node3	44	3405312	1.5712e+04	0
4 Node4	0	4 Node4	8.1754e+04	13.4392	4 Node4	78	1618944	8.1240e+03	0.8164
5 Node5	0	5 Node5	8.5008e+04	0	5 Node5	79	1179648	5.3280e+03	1
6 Node6	0	6 Node6	9.1293e+04	0	6 Node6	68	577536	2.1440e+03	1
7 Node7	0	7 Node7	3.5938e+04	422.3747	7 Node7	27	11010048	4.8944e+04	0
8 Node8	0	8 Node8	7.0170e+04	186.8288	8 Node8	40	4737024	2.1740e+04	0
9 Node9	2.0930e+03	9 Node9	8.9064e+04	0	9 Node9	93	0	0	0
10 Node10	1.8110e+03	10 Node10	9.0535e+04	0	10 Node10	27	0	0	0
11 Node11	578.0000	11 Node11	9.5092e+04	0	11 Node11	44	0	0	0
12 Node12	846.0000	12 Node12	9.2298e+04	0	12 Node12	89	0	0	0
13 Node13	2.3120e+03	13 Node13	9.1853e+04	0	13 Node13	115	0	0	0
14 Node14	1.0720e+03	14 Node14	9.4632e+04	0	14 Node14	66	0	0	0
15 Node15	2.3070e+03	15 Node15	9.1017e+04	0	15 Node15	26	0	0	0
16 Node16	3.2790e+03	16 Node16	8.8618e+04	0	16 Node16	68	0	0	0

With the increase of TxMCs to 11 we notice that in node[2] the Packet loss has been eliminated. Also we notice the fluctuations that have occurred in the bandwidth – Packet Loss and the Average Packet Latency in all nodes.

In the Mac state we can observe more slices in the pie.

**CASE 12**

In this case we kept the data of the previous measurement [case 10] and we just run it with 2 generator for greater accuracy in simulation result and we as we can see the difference from the previous measurement.

With the second generator we can see that our results is more stable and our accuracy is better.

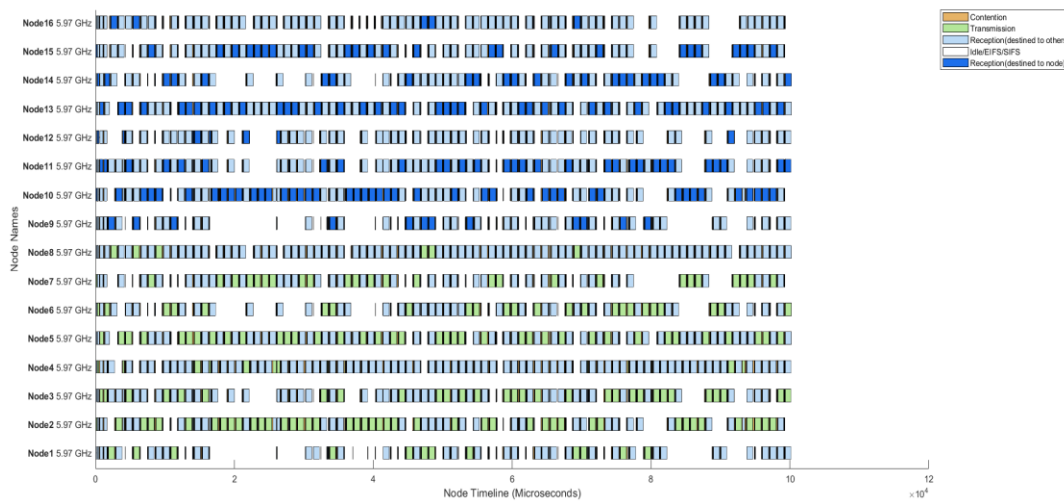

**FIGURE 87 : MAC STATE OVER TIME WITH(2 GENERATORS)**

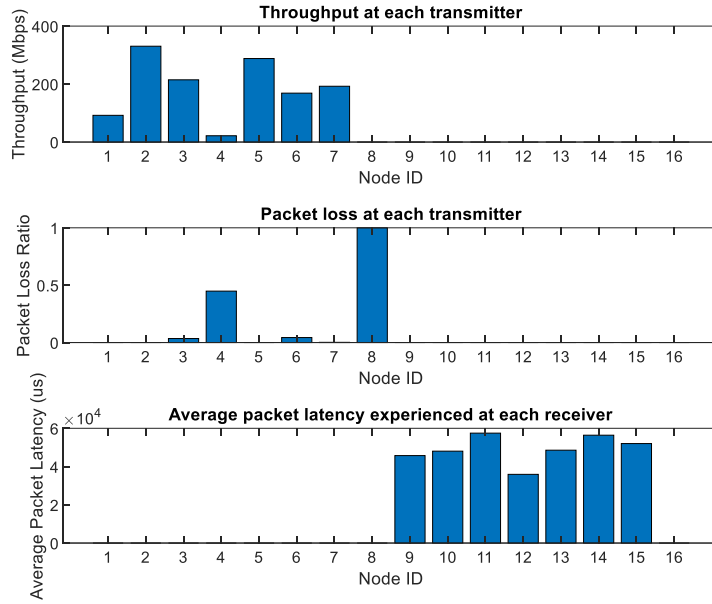

FIGURE 88 : THROUGHPUT - PACKET LOSS - AVERAGE PACKET LATENCY (2 GENERATORS)

	2	3	4	5	66	85	86	87	88
	AppTx	AppRx	AppRxBytes	AppAvgPacketLatency	Throughput	MACNumBasicNavUpdates	PhyTxBytes	PhyTxTime	PacketLossRatio
1 Node1	5000	0	0	0	+04 92.1574	60	2457600	1.0708e+04	0
2 Node2	5000	0	0	0	+04 330.5907	43	8458752	3.8284e+04	0
3 Node3	5000	0	0	0	+04 214.6740	54	5501952	2.4952e+04	0.0351
4 Node4	5000	0	0	0	+04 21.7194	95	995328	5.0680e+03	0.4482
5 Node5	5000	0	0	0	+04 288.1119	61	7325184	3.3308e+04	0
6 Node6	5000	0	0	0	+04 168.7153	54	4394496	1.9624e+04	0.0435
7 Node7	5000	0	0	0	+04 192.4746	62	4925952	2.2416e+04	0.0019
8 Node8	5000	0	0	0	+04 0	99	1179648	5.3280e+03	1
9 Node9	0	768	1152000	4.5731e+04	+04 0	59	0	0	0
10 Node10	0	2755	4132500	4.8046e+04	+04 0	42	0	0	0
11 Node11	0	1789	2683500	5.7473e+04	+04 0	55	0	0	0
12 Node12	0	181	271500	3.5919e+04	+04 0	73	0	0	0
13 Node13	0	2401	3601500	4.8556e+04	+04 0	60	0	0	0
14 Node14	0	1406	2109000	5.6395e+04	+04 0	52	0	0	0
15 Node15	0	1604	2406000	5.2021e+04	+04 0	66	0	0	0
16 Node16	0	0	0	0	+04 0	89	0	0	0

SUMMARY OF PERFORMANCE RESULTS SCENARIO I							
Deployment Parameters	Cases	Component		Throughput (transmitter)	Packet Loss Ratio (transmitter)	Average Packet Latency (receiver)	
		Nodes	Parameters				
2 [Floors] 12x12x2 [Room Size] 2x2x2 [Building Layout] 1 [Stations Per Room] 16 [Number Of Nodes]	2	↑ [1]	TxMCS	Increase ↗	↔	A little bit increase ↗	
	3	↑ [1]	Packet size of node	Decrease ↘ to zero	Increase ↗	Decrease ↘ to zero	
	4	↑ [1]	Datarate of Node	Decrease ↘	Decrease ↘ to zero	Decrease ↘	
	5	↑ [1]	Threshold	Decrease ↘ to zero	Increase ↗	Decrease ↘	
	6	↑ [1]	TxPower	Decrease ↘	Decrease ↘ to zero	Decrease ↘	
	7	↑ [1]	MaxSubFrames	Decrease ↘ to zero	Increase ↗	Decrease ↘	
	8	↑ to all nodes	Bandwidth	Increase ↗↗	Decrease ↘	↔	
	9	6GHz [1]	Band to one node	Decrease ↘ to zero	Increase ↗	Decrease ↘ to zero	
	10	6GHz to all nodes	Band to all nodes	Increase ↗↗	Decrease ↘	Increase ↗↗	
	12	6GHz to all nodes	2 Generators	Greater accuracy in simulation result and we as we can see the difference from the previous measurement.			

TABLE 13 : SUMMARY OF PERFORMANCE RESULTS



**SCENARIO II**

In the same scenario, we change the parameters of the building with 1 floor and one room. The dimensions are 10m x 10m x 2m. In the room we have one access point (AP) and one station (STA) placed randomly. In total we have two nodes without interfere between the nodes walls and floors. The parameters used in the simulation are detailed in Table 12.. The Results again plots performance metrics such as throughput, latency, and packet loss, which will be explained below.

Deployment Parameters	Value
Floors	1
Room Size	10x10x2
Building Layout	1x1x1
Stations Per Room	1
Number Of Nodes	2 [One AP and One STA]

PHY & MAC Parameters	Value
Operating frequency	2.4 GHz
STA sensitivity	-82dBm
Channel bandwidth	20
Tx Format	HE_SU
TxPower	15
Packet Size	1500
Frequencies	5.9 GHz
Band and Channel	6 GHz
Max SubFrames	64

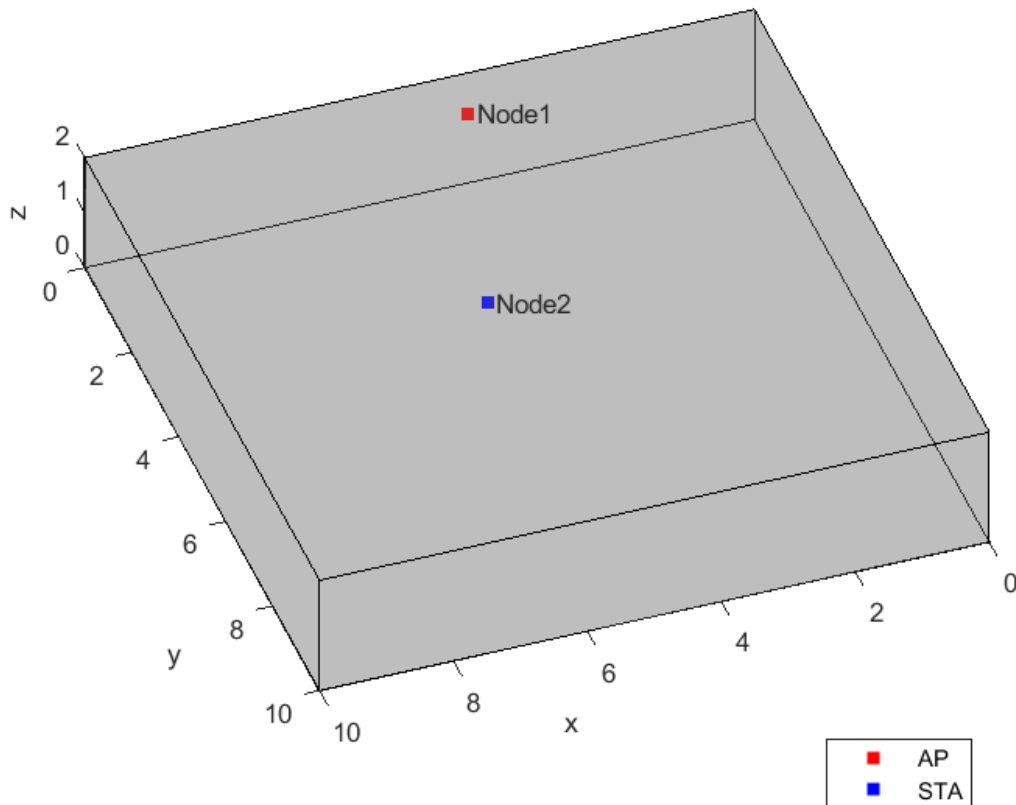

FIGURE 89 : ROOM SIZE PARAMETERS

### CASE 1

In the first case we simulate a room size with 10x10x2 and with all nodes transmit 1500 bytes of packet, DataRate 600000Kbps. The frequency is 2.4Ghz the band at 6GHz and the channel at 6GHz. The bandwidth of nodes is 20 and the TxMCS 7.

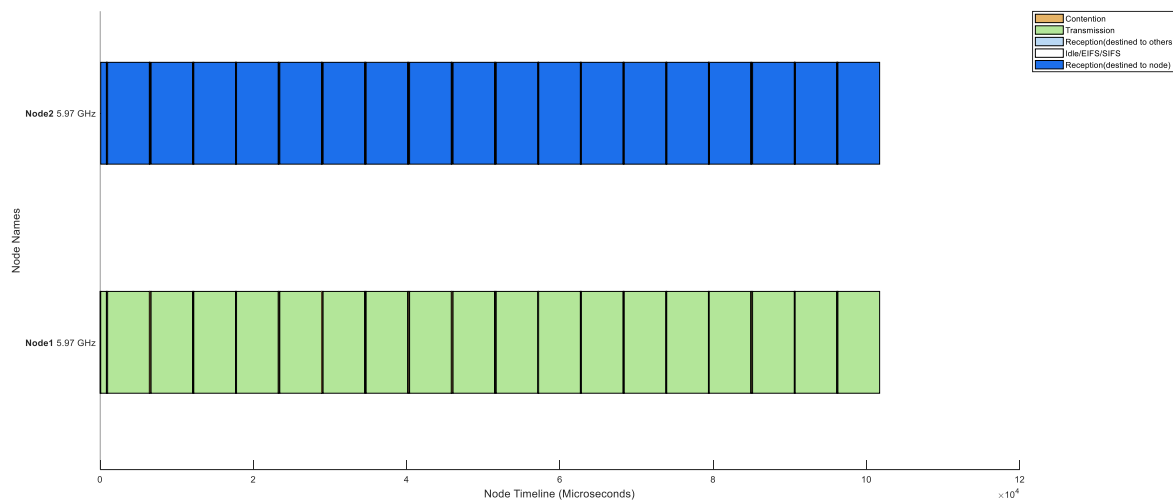

FIGURE 90 :MAC STATE OVER TIME WITH (2 NODES)

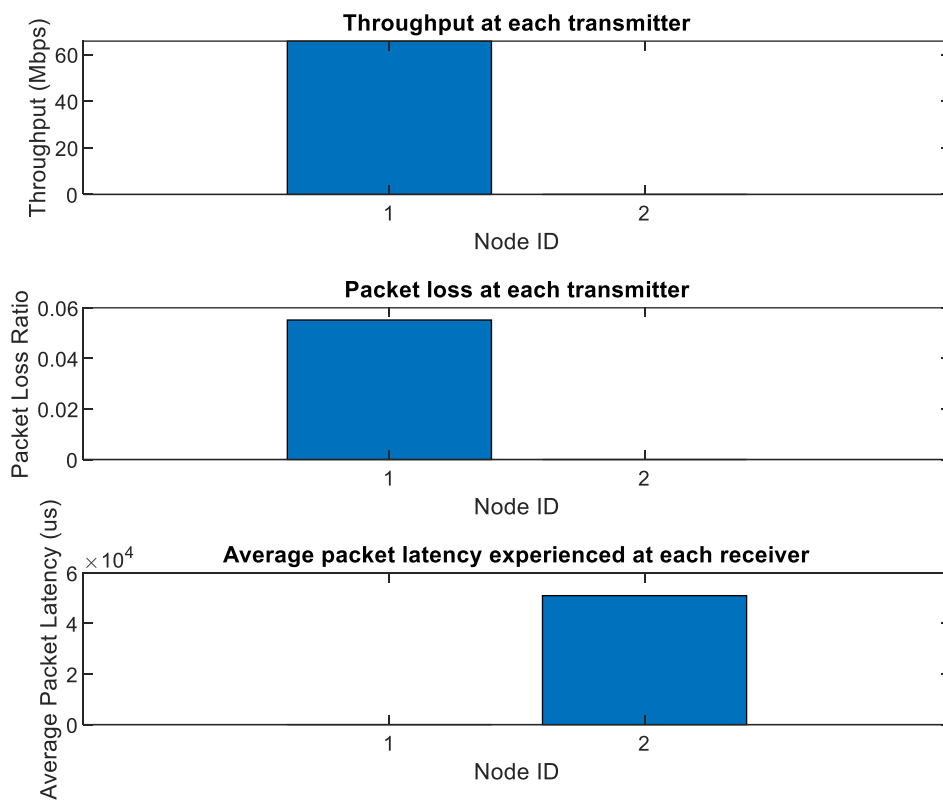
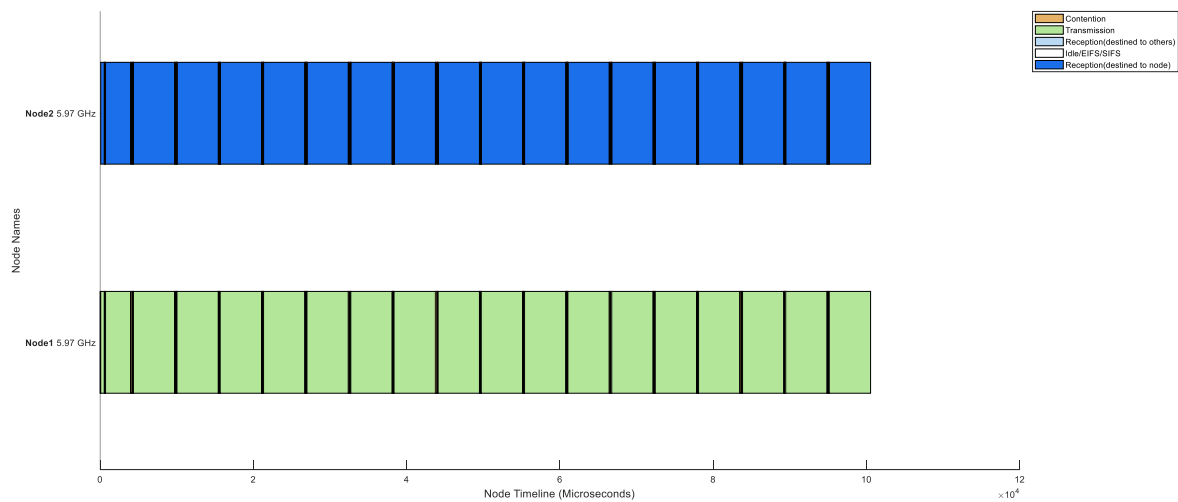

FIGURE 91 : THROUGHPUT - PACKET LOSS - AVERAGE PACKET LATENCY (2 NODES)

	1	2	3	4	5	66	88
	ActiveOperationInFreq	AppTx	AppRx	AppRxBytes	AppAvgPacketL	Throughput	PacketLossRatio
1 Node1	1	5000	0	0	0	65.7448	0.0552
2 Node2	1	0	548	822000	5.0999e+04	0	0

**CASE 2**

In the second case we kept the same parameters as the first case and we change the TXMCS to 11 at the two nodes.



**FIGURE 92 : MAC STATE OVER TIME WITH (2 NODES – TXMCS 11)**

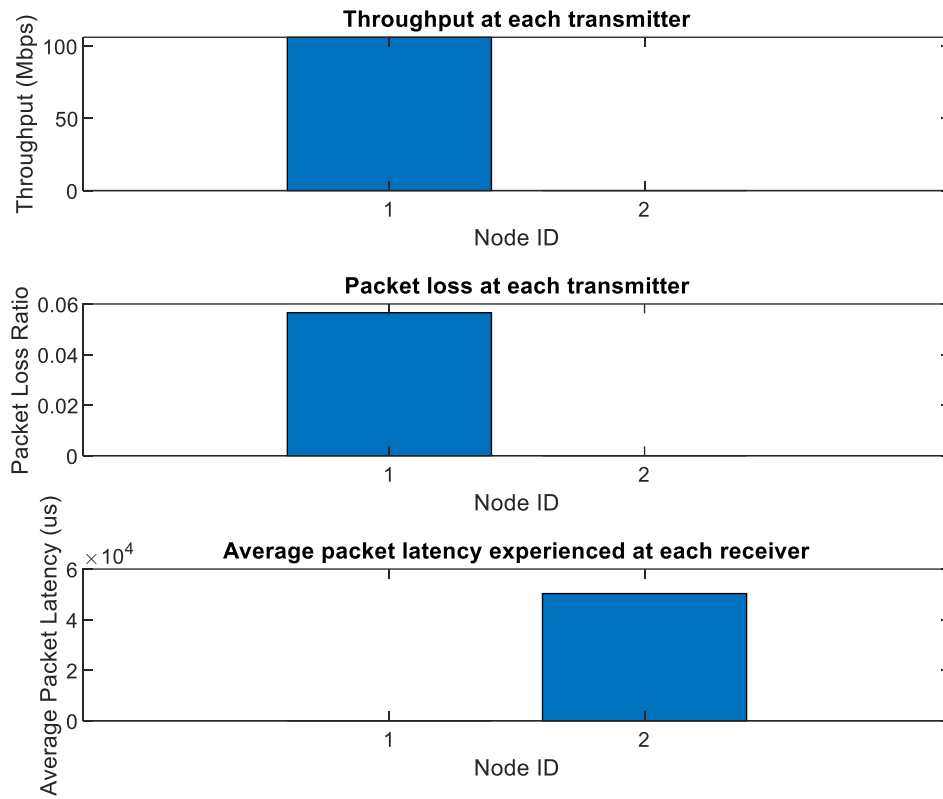

FIGURE 93 :THROUGHPUT - PACKET LOSS - AVERAGE PACKET LATENCY (2 NODES - TXMCS 11)

	1	2	3	4	5	66	88
	ActiveOperationInFreq	AppTx	AppRx	AppRxBytes	AppAvgPacketLatency	Throughput	PacketLossRatio
1 Node1	1	5000	0	0	0	106.0442	0.0566
2 Node2	1	0	884	1326000	5.0306e+04	0	0

When we change the TXMCS in two nodes we observe the increase of throughput.

**CASE 3**

In this case we kept the same parameters as the second case and we increase the bandwidth in the nodes with the value 160.

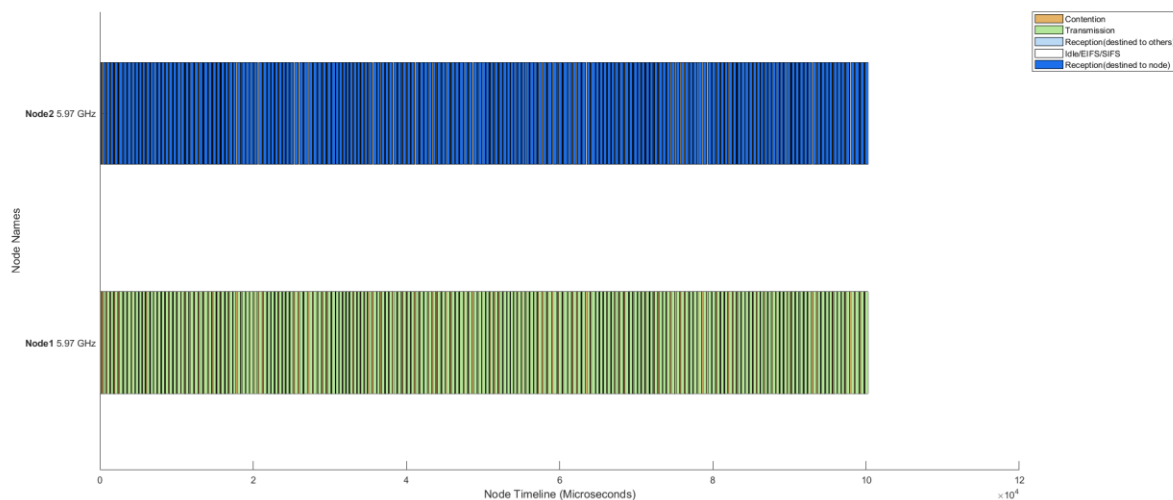

**FIGURE 94 : FIGURE 92 : MAC STATE OVER TIME WITH (2 NODES – BW 160)**

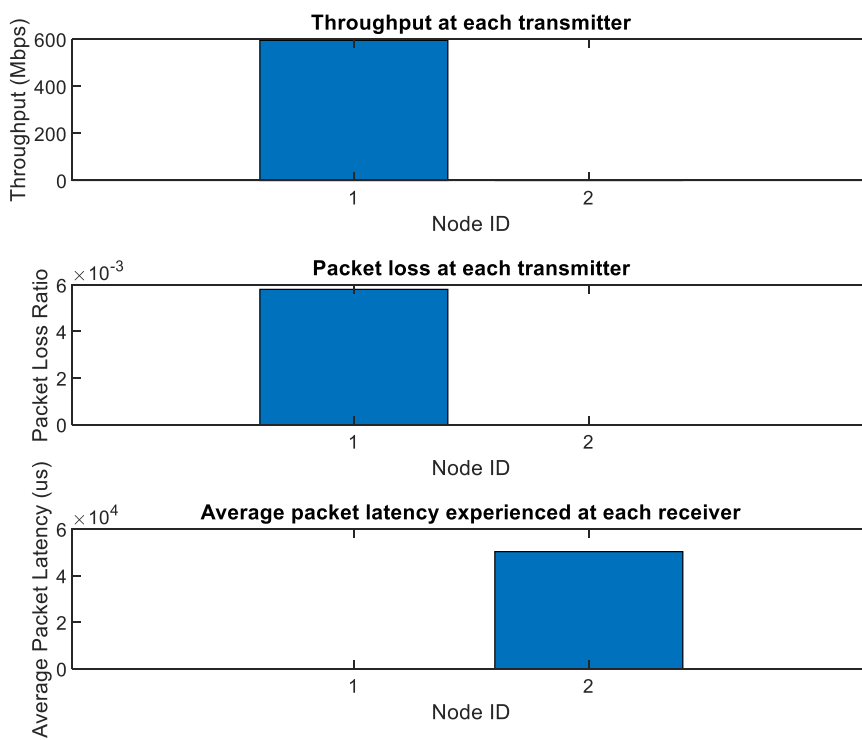

**FIGURE 95 : THROUGHPUT - PACKET LOSS - AVERAGE PACKET LATENCY (2 NODES - BW 160)**

		2	3	4	5	66	88
	req	AppTx	AppRx	AppRxBytes	AppAvgPacketLatency	Throughput	PacketLossRatio
1 Node1	1	0	0	0	0	595.6662	0.0058
2 Node2	1	0	4964	7446000	5.0300e+04	0	0

With the increase of bandwidth in two nodes we can see the big increase in bandwidth at the transmitter and the decrease in Packet loss Ratio.

At the MAC State we can observe the changes during the time.

				SUMMARY OF PERFORMANCE RESULTS SCENARIO II		
Deployment Parameters	Cases	Nodes	Component	Throughput (transmitter)	Packet Loss Ratio (transmitter)	Average Packet Latency (receiver)
			Parameters			
1 Floor 10x10x2 [RoomSize] 1x1x1 [BuildingLayout] 1 [Stations Per Room] 1 [Number Of Nodes]	1	Channel and Band 6GHz	Band to all nodes	65,7Mbps	0,0552	5,0999e + 04
	2	TXMCs ↑ [1][2]	TXMCs	106,0442Mbps	0,0566	5,0306e + 04
	4	bandwidth 160[1][2]	bandwidth	595,6662	0,0058	5,0300e + 04

## 7. CONCLUSION

The 802.11be modification is the next major milestone in the long-term success of Wi-Fi. Its key features are related to providing extremely High Throughput that can support real time applications. Social Networking, VR / AR, the internet of things, and ultra-high speed content delivery place challenging WLAN requirements. The designing PHY and MAC with performance for EHT is a challenge and exciting research area.

In this thesis we have discussed the main objectives, techniques, the main innovation, and the timelines for the EHT WLAN.

We discussed about the 6GHz Band, the 4096-QAM, Multi RU Support, Multi Ap Coordination, the Multi Link Aggregation, MIMO Enhancements and HARQ.

We studied the EDCA and OFDMA modifications will provide to support for RTA, OFDMA will be more flexible to improve spectrum efficiency.

The Functionality of Multi Link in the WIFI adds flexibility in the use of resource and offer higher bandwidth and throughputs.

The Technical features of the new PHY and MAC Layer should be well defined and backward compatible with time sensitive mode to support low latency communications.

We see that one of target scenario of WIFI community is to Achieve Extremely High throughput and to improve the worst-case latency and jitter. Although the standard development process is at an early stage. There is an open issue which require additional efforts and studies from the community.

The 802.11be has just started and everything is open. Also, in this thesis we provide an overview of the time sensitive networking enhancements that can include four key components: Time synchronization, traffic shaping and scheduling, ultra-reliability, and resource management.

Although time sensitive networking can open many possibilities for future WIFI, its successful implantation to support real time applications.

In the end we designed and studied a simulation with results in throughput, Packet Loss Ratio and Average Packet Latency in the receiver of a typical enterprise scenario. Otherwise WIFI 7 has just start and everything is open for the future, one is for sure the

FUTURE WILL BE BRIGHT.



## REFERENCES

- [1] <https://www.wi-fi.org/news-events/newsroom/wi-fi-alliance-publishes-2018-wi-fi-predictions>
- [2] <https://www.computerworld.com/article/2802953/a-brief-history-of-wireless-technology.html>
- [3] <https://tel.archives-ouvertes.fr/tel-02986448/document>
- [4] 802.11® Wireless Networks: The Definitive Guide By Matthew Gast
- [5] [https://www.net.t-labs.tu-berlin.de/teaching/computer\\_networking/05.07.htm](https://www.net.t-labs.tu-berlin.de/teaching/computer_networking/05.07.htm)
- [5] <http://gomeasure.dk/wp-content/uploads/2017/04/IOT-4.pdf>
- [6] [https://ethw.org/Wireless\\_LAN\\_802.11\\_Wi-Fi](https://ethw.org/Wireless_LAN_802.11_Wi-Fi)
- [7] [https://www.researchgate.net/publication/320662734\\_WiFi\\_Alliance\\_Connecting\\_Everyone\\_and\\_Everything\\_Everywhere](https://www.researchgate.net/publication/320662734_WiFi_Alliance_Connecting_Everyone_and_Everything_Everywhere)
- [8] <https://www.diva-portal.org/smash/get/diva2:1029318/FULLTEXT01.pdf>
- [9] [http://media.techtarget.com/searchMobileComputing/downloads/CWAP\\_ch8.pdf](http://media.techtarget.com/searchMobileComputing/downloads/CWAP_ch8.pdf)
- [10] [https://www.researchgate.net/publication/319486470\\_A\\_Survey\\_of\\_IEEE\\_80211\\_Protocols\\_Comparison\\_and\\_Proerspective](https://www.researchgate.net/publication/319486470_A_Survey_of_IEEE_80211_Protocols_Comparison_and_Proerspective)
- [11] [https://www.arubanetworks.com/assets/so/SO\\_80211ax.pdf](https://www.arubanetworks.com/assets/so/SO_80211ax.pdf)
- [12] <https://www.cisco.com/c/en/us/products/collateral/wireless/white-paper-c11-740788.html#32Howdoes80211axgosofast>
- [13] <https://www.ni.com/en-us/innovations/white-papers/16/introduction-to-802-11ax-high-efficiency-wireless.html#:~:text=802.11ax%2C%20also%20called%20High,4X%20in%20dense%20user%20environments.>
- [14] [https://res-www.zte.com.cn/mediares/zte/Files/PDF/white\\_book/WiFi\\_6\\_Technology\\_and\\_Evolution\\_White\\_Paper-20200923.pdf?la=en](https://res-www.zte.com.cn/mediares/zte/Files/PDF/white_book/WiFi_6_Technology_and_Evolution_White_Paper-20200923.pdf?la=en)
- [15] <https://www.ni.com/en-us/innovations/white-papers/16/introduction-to-802-11ax-high-efficiency-wireless.html>
- [16] <https://arxiv.org/ftp/arxiv/papers/1806/1806.05908.pdf>
- [17] <https://www.ekahau.com/wp-content/uploads/2020/06/Webinar-slides-802.11ax-Sneak-Peek-%E2%80%93-The-Next-Generation-Wi-Fi.pdf>
- [18] <https://www.juve-patent.com/sponsored/wi-fi-6-key-innovations-and-their-contributors-part-2/>
- [19] <https://www.minim.com/blog/what-is-wifi-6-ofdma-vs-ofdm-explained>
- [20] <https://arxiv.org/ftp/arxiv/papers/1806/1806.05908.pdf>
- [21] <https://www.rfwireless-world.com/Terminology/What-is-BSS-Coloring-in-WLAN-802-11ax.html>

- [22] <https://www.commscope.com/globalassets/digizuite/62443-wp-idc-evaluating-802-11ax-wi-fi-standard.pdf>
- [23] [https://www.theseus.fi/bitstream/handle/10024/346134/Bhandari\\_Hari\\_and\\_Devkota\\_Bibek.pdf?sequence=2](https://www.theseus.fi/bitstream/handle/10024/346134/Bhandari_Hari_and_Devkota_Bibek.pdf?sequence=2)
- [24] <https://arxiv.org/pdf/2008.02815.pdf>
- [25] [https://cdn2.hubspot.net/hubfs/6705264/Marketing/Whitepapers/The%20Future%20Of%20Wi-Fi/ABI%20Research\\_The\\_Future\\_Of\\_Wi-Fi.pdf?hsCtaTracking=70aa0e89-7f51-47fc-958b-ecb8472fd516%7C9f6ac5bd-19a2-4a5c-bc79-04151f6cb9f5#:~:text=The%20year%202019%20marked%20the,no%20signs%20of%20slowing%20down.&text=As%20the%20chart%20below%20shows,than%204.5%20billion%20by%202024.](https://cdn2.hubspot.net/hubfs/6705264/Marketing/Whitepapers/The%20Future%20Of%20Wi-Fi/ABI%20Research_The_Future_Of_Wi-Fi.pdf?hsCtaTracking=70aa0e89-7f51-47fc-958b-ecb8472fd516%7C9f6ac5bd-19a2-4a5c-bc79-04151f6cb9f5#:~:text=The%20year%202019%20marked%20the,no%20signs%20of%20slowing%20down.&text=As%20the%20chart%20below%20shows,than%204.5%20billion%20by%202024.)
- [26] [qorvo-the-wi-fi-evolution-white-paper%20.pdf](https://arxiv.org/pdf/2008.02815.pdf)
- [27] [https://www.researchgate.net/publication/343546727\\_IEEE\\_80211be\\_Wi-Fi\\_7\\_Strikes\\_Back](https://www.researchgate.net/publication/343546727_IEEE_80211be_Wi-Fi_7_Strikes_Back)
- [28] <https://ieeexplore.ieee.org/document/9090146>
- [29] <https://ieeexplore.ieee.org/document/9152055>
- [30] <https://www.mdpi.com/2076-3417/11/1/317>
- [31] [https://www.researchgate.net/publication/342257387\\_Survey\\_and\\_Perspective\\_on\\_Extremely\\_High\\_Throughput\\_EHT\\_WLAN\\_-\\_IEEE\\_80211be](https://www.researchgate.net/publication/342257387_Survey_and_Perspective_on_Extremely_High_Throughput_EHT_WLAN_-_IEEE_80211be)
- [32] [https://mentor.ieee.org/802.11/documents?is\\_dcn=1095&is\\_group=00be.](https://mentor.ieee.org/802.11/documents?is_dcn=1095&is_group=00be)
- [33] [https://www.researchgate.net/publication/342257387\\_Survey\\_and\\_Perspective\\_on\\_Extremely\\_High\\_Throughput\\_EHT\\_WLAN\\_-\\_IEEE\\_80211be](https://www.researchgate.net/publication/342257387_Survey_and_Perspective_on_Extremely_High_Throughput_EHT_WLAN_-_IEEE_80211be)
- [34] <https://arxiv.org/pdf/1912.06086.pdf>
- [35] <https://ui.adsabs.harvard.edu/abs/2019arXiv191206086A/abstract>
- [36] <https://deepai.org/publication/time-sensitive-networking-in-ieee-802-11be-on-the-way-to-low-latency-wifi-7>